

3709
13.60
Copy No. 10

RESTRICTED.

The information given in this document is not to be communicated, either directly or indirectly to the Press or to any person not authorised to receive it.

**INTER-SERVICE
AMMUNITION
&
AMMUNITION PACKAGE
MARKINGS**

ADMIRALTY No. BR 1202

WAR OFFICE No. 57/AMMUNITION/4068

AIR MINISTRY No. A.885820/46/D.D.Arm.

Oakley CW

Admiralty No. BR 1202 (1948)
War Office No. 57/Amn./4068
Air Ministry A.P. 3095

RESTRICTED

The information given in this document is not to be communicated, either directly or indirectly, to the Press or to any person not authorized to receive it.

W.O.
CODE No.
1803-1

INTER-SERVICE AMMUNITION AND AMMUNITION PACKAGE MARKINGS

AMENDMENT No. 1

COVER, W.O. CODE No. 1803 AND ERRATUM

Delete "ADMIRALTY No. BR 1202" and substitute:
"ADMIRALTY No. BR 1202 (1948)".

Delete "AIR MINISTRY No. A.885820/46/D.D.ARM." and substitute:
"AIR MINISTRY A.P.3095".

SECTION 1

TITLE PAGE.

Delete "Admiralty No. BR 1202 A47" and substitute:
"Admiralty No. BR 1202 A(1948)".

Delete "Air Ministry No. A 885820/46/D.D.Arm." and substitute:
"Air Ministry A.P. 3095".

Delete "W.O. Code No. 3419" and substitute "W.O. Code No. 1803".

SECTION 2

TITLE PAGE.

Delete "Air Ministry No. A 885820/46/D.D.Arm." and substitute:
"Air Ministry A.P.3095".

Delete "W.O. Code No. 3420" and substitute "W.O. Code No. 1803".

Page 22.

Fig. 22. *Delete* relevant detail and *substitute* :

Amdt. 1/Apr./1949.

852	852
66.6%	Petn.	
3.0%	HM Nitro cotton	
0.4%	Blasting soluble Nitro cotton	
29.5%	Low freezing Nitro body	
0.5%	Resin	

Below end of table insert :

Amdt. 1/Apr./1949.

26	RDX/WAX/AL	RDX/AL ₂
	68% RDX (grade 1 or 1A)	
	12% Wax (paraffin)	
	20% Aluminium	

SECTION 4

TITLE PAGE.

Delete " Air Ministry No. A 885820/46/D.D.Arm." and *substitute* :
" Air Ministry A.P. 3095 ".

Delete " W.O. Code No. 5858 " and *substitute* " W.O. Code No. 1803 ".

SECTION 8

TITLE PAGE.

Delete " Air Ministry No. A 885820/46/D.D.Arm." and *substitute* :
" Air Ministry A.P. 3095 ".

Delete " W.O. Code No. 3421 " and *substitute* " W.O. Code No. 1803 ".

Oakley (G.W.)

Admiralty No. BR 1202 (1948)
War Office No. 57/Amn./4068
Air Ministry A.P. 3095

RESTRICTED

The information given in this document is not to be communicated, either directly or indirectly to the Press or to any person not authorized to receive it.

W.O.
CODE No.
1803-2

INTER-SERVICE AMMUNITION AND AMMUNITION PACKAGE MARKINGS

(AMENDMENTS No. 2)

MANUSCRIPT AMENDMENTS

SECTION 1.—General Introduction

Page 7. Para. 9 :

Line 4. Heading of table. *Delete "1947" and substitute "1948"*.

Line 19. *Against "Orange" delete "Deep No. 590" and substitute "Deep No. 591"*.

SECTION 2.—Projectiles and Aircraft Bombs

Page 3.

CONTENTS. Line 10. *After "Coloured tips" add "and bases"*.

Page 4.

C. *Below "Coloured—" insert "bases ... 8.2 13"*.

D. *Delete all detail under "Details of fuze" and substitute :*

" Land Service	17.3	16
Naval Service	17.1, 17.2	16 "

Page 5.

Line 5. *Under "size" add "symbols ... 9.4 13"*.

F. *Delete all indented detail below "Fuze details" and substitute :*

" Land Service	17.3	16
Naval Service	17.1, 17.2	16 "

Page 8.

S. *Below* " Symbols—tracer " *add* :

" dimensions, chevron	13.2	15
dimensions, curved	13.1	15 "

T. *Below* " Tracer symbols " and *under* " chemical projectiles and Aircraft bombs " *add* :

" dimensions, chevron	13.2	15
dimensions, curved	13.1	15 "

Page 9. Sub-para. 2.1. Table :

First column. *Against* " White " *add* " ϕ ".

Second and fourth columns. *Against* " White ". *Delete* " Star or flare " and *substitute* " Star or illuminating flare ".

Fourth column. Line 1. *After* " High explosive " *add* " * * ".

Fourth column. Line 13. *After* " Radar Echo " *insert* " Signal Flare ".

Page 13.

Para. 8. Line 1. *Delete* " COLOURED TIPS " and *substitute* " COLOURED TIPS AND BASES ".

Sub-para. 8.1. *Delete* line 2 and *substitute* " In the case of uncapped shot, the width of the tip is as follows : "

Page 14. Sub-para. 10.3.

Line 1. *Delete* " H.E. " (twice).

Line 3. *Delete* " H.E. shell " and *substitute* " Shell ".

Page 19. Serial 3. Third column.

Delete " TNT/1 ", " TNT/2 " and " TNT/3 " and *substitute* " TNT 1 ", " TNT 2 " and " TNT 3 " respectively.

Plate 1 (facing page 18).

Fig. 1 " HIGH EFFECT SHELL (NAVAL) " :

Delete " SERIAL NO. " and *substitute* " FUZED SERIAL NO. ".

Delete " FUZE PARTICULARS ONLY REQUIRED WHEN SHELL ARE FUZED NOS. 360, 18P, 44 AND 45P. ".

Plate 3 (facing page 23).

Fig. 6. *Delete* " AND REQUIRING A DIFFERENT CHARGE, e.g. 5.5-in. 80 LB. ".

Fig. 7. *Delete* " H.E. DRILL " and *substitute* " Drill ".

Page 23. Table.

Serial 7. Second column. *Delete* " HE drill " and *substitute* " Drill ".

Serial 12. Second column.

Lines 1 and 2. *Delete* " HE " (twice).

Line 4. *After* " fuze " *add* " (see sub-para. 10.3) ".

Third column. Line 2. *After* " nose " *insert* " , or White stripes in the case of shell whose basic colour is Black ".

Plate 4 (facing page 24). " TYPICAL CHEMICAL SHELL ".

Details on diagram.

Number " 8 " (with three arrows). *Re-number* as " 9 ".

Number " 9 " (with one arrow). *Re-number* as " 8 ".

Details below diagram :—

Delete " 8 " and detail.

Re-number " 9 " as " 8 ".

Below " BODY CHARGING " *insert* " 9. TYPE OF CHARGING RINGS ".

Detail against " 14 ". *Delete* " CHARGING " and *substitute* " CHARGED ".

Page 26.

Third column :—

Heading. Line 3. *Delete* " shoulder or ".

Serials 4 and 5. *Insert* " WP ".

Serial 6. *Insert* " FM ".

Fourth column :—

Line 1. *After* " Composition " *insert* " or charging ".

Line 2. *Delete* " or above ".

Line 5. *After* " emission types " *add* " , or nature of charging, in bursting types ".

Page 27.

Third column :—

Serial 4. *Insert* " FM ".

Serial 6. *Delete* detail.

Serial 9. *Insert* " WP ".

Fourth column :—

Serial 6. Line 5. *After* " charge " *add* " (Land Service only) ".

Serial 7. *Insert* " Red ring in this instance denotes the presence of tracer filling ".

Serial 13. Lines 4 and 5. *Delete* " immediately below " and *substitute* " on ".

Page 30. Third column.

Serial 3. *Insert* " FM ".

Serial 4. *Insert* " CSAM ".

Serial 5. *Insert* " WP ".

Serials 6, 7 and 9. Line 2. *Delete* " above " and *substitute* " on " (three times).

Plate 9 (facing page 31).

After " BASIC COLOUR ", at bottom of plate, *delete* full stop and *add* " AND STENCILLING ON VARNISH WILL BE IN WHITE ".

Page 31. Serial 3. Third column.

Insert " WP ".

SECTION 8.—Pyrotechnics

Page 5. Sub-para. 3.1. Table. First column.

Against " White " *add* " * ".

Below table *add* : " * In Air Service these stores are painted black as an operational camouflage ".

CUT-OUT AMENDMENTS

SECTION 2.—Projectiles and Aircraft Bombs

Page 9. Sub-para. 2.1. Notes under table. *Add* :

Amdt. 2/Oct./1950

** Including high explosive anti-tank (*i.e.*, shaped charge), and high explosive squash head projectiles abbreviated as HE/AT, HE/SH, respectively.

φ In Air Service these stores are painted black as an operational camouflage.

Page 12. *Delete* sub-para. 5.3 and *substitute* :

Amdt. 2/Oct./1950

5.3. The position of the " method of functioning " rings is normally on the shoulder in the case of shell, and on the body in the case of mortar and aircraft bombs. When forming part of combination rings it will necessarily be displaced below the shoulder.

Page 13.

Add new sub-para. 8.2 :

Amdt. 2/Oct./1950

8.2. *Bases*

Bases will be painted with the appropriate colour as far as the driving band, except in the case of shot used only with fixed rounds where this colouring is not necessary.

Add new sub-para. 9.4 :

Amdt. 2/Oct./1950

9.4. Symbols indicating smoke box, star or flare projectiles, and flash pellets, are located on the ogive of the projectile.

Page 14. Delete sub-para. 11.1 and substitute :

Amdt. 2/Oc./1950

11.1. *Calibre and Mark*

The calibre, identifying letter, and mark of the ordnance to be stencilled above the nature and mark of the projectile, excepting 6-pr. and below. The identifying letters to be "M" for Mortar; "H" for Howitzer; and "G" for Gun, e.g. :—

4.2" M Mk. 2	5.5" G Mk. 3	7.2" H Mk. 6
SMK BE Mk. 1	HE 80-lb. Mk. 3	HE Mk. 2
20-pr. G Mk. 1	6" G Mk. 24	
APCBC Mk. 1	HE SAPBC Mk. 6	

In *Naval Service* the identifying letter, mark of ordnance and nature of projectile are omitted.

NOTE.—The mark of ordnance will not be necessary where the same ammunition is suitable for various marks of equipment.

Page 15.

Add new sub-para. 11.6 :

Amdt. 2/Oct./1950

11.6. In *Land Service* a new and more comprehensive code system for the method of filling details will gradually be introduced, beginning with projectiles for the Q.F. 25-pr.

In the new system a code letter will be allocated to each type of projectile in place of the "L" in the existing system (*see* sub-para. 11.4 above). For convenience, the letter used for a given type will be the same as that used for the type with a full charge in the batching system of marking (*see* Section 3, sub-para. 4.5). Where the type is not included in the batching system a new code letter will be introduced. The letters "L", "N" and "I" will not be used in this system.

A code number will be given to each method of filling design, beginning with unity for each type of projectile for a given gun. Each of the variations permitted by the method of filling design (e.g. alternative bursting charges or exploders) will be given a sub-number which will follow the main number and be prefixed by an oblique stroke. A typical example for an H.E. shell would be "B 12/1" (followed in the normal way by the filling contractors' monogram and month and year of filling) where :—

B indicates the type of shell to be H.E.

12 is the code number of the method of filling design.

/1 is the sub-number indicating a particular variation authorized in the design indicated by the code number 12 above.

Add new sub-paras. 13.1 and 13.2 :

Amdt. 2/Oct./1950

13.1. *Dimensions, curved tracer symbol*

The curved tracer symbol is of the following dimensions :—

Projectiles below 4-in.

Internal radius ... $\frac{1}{4}$ -in.

Thickness ... $\frac{1}{8}$ -in.

Projectiles 4-in. to below 6-in.

Internal radius ... $\frac{1}{2}$ -in.

Thickness ... $\frac{3}{16}$ -in.

Projectiles 6-in. and above

Internal radius ... 1-in.

Thickness ... $\frac{3}{16}$ -in.

The bar symbol associated with a tracer fuze is of corresponding dimensions, the length being equal to twice the radius. The space between the bar and the curve is equal to the thickness.

13.2. *Dimensions, chevron symbol*

The chevron symbol associated with igniters is of the following dimensions :—

Projectiles 6-pr. and below

The angle between the two arms of the chevron is 90 degrees.

The length of each of the arms is $\frac{1}{16}$ -in.

The thickness of the arms is $\frac{1}{8}$ -in.

Page 16. Delete para. 17 and all detail and substitute :

Amdt. 2/Oct./1950

17. FUZE DETAILS.

17.1. The following details are stencilled on Naval fuzed projectiles :—

FZD denoting that projectile is fuzed.

Serial number of fuze.

Filled lot number and mark of fuze.

Date of filling of the fuze.

Initials of the maker of the empty fuze or monogram of the converting station.

17.2. In *Naval Service*, similar information of the gaine, where fitted, is also stencilled on the shell.

17.3. In *Land Service*, the marking "FZD LOT", followed by the lot number is used, on base filled shell.

Page 17. Delete para. 26, "STAMPINGS", and all detail and substitute :

Amdt. 2/Oct./1950

STAMPINGS

26. Stamping is used to indicate details of manufacture and inspection. It is not normally required by the User. In *Naval* and *Land Services*, additional stamping is used to facilitate identification should other markings become obliterated.

In *Naval Service*, the code letters indicating nature of filling are used (*see* pages 19-22).

In *Land Service* the "Method of Filling" code is used in addition to the nature of filling code letters. When the new "Method of Filling" code (*see* sub-para. II.6) comes into use in Land Service, it will be used alone. The stamping is in $\frac{1}{4}$ -in. type and is over-painted by the type of filling or charging ring.

Plate 1 (facing page 18). *Add* at bottom of plate as a footnote :

Amdt. 2/Oct./1950

NOTE.—CALIBRE, IDENTIFYING LETTER AND MARK, WITH NATURE AND MARK OF PROJECTILE HAVE NOT BEEN SHOWN IN FULL IN THE TYPICAL DIAGRAMS (*see* SUB-PARA. II.I).

Page 19. *Delete* Serials 1 and 2 and all detail, and all detail in fourth column.

Substitute :

Amdt. 2/Oct./1950

1	Lyddite	LYD.	No type of filling ring is shown on Lyddite or CE fillings.
2	CE	CE	

Plate 4 (facing page 24). *Add* at bottom of plate as a footnote :

Amdt. 2/Oct./1950

NOTE.—CALIBRE, IDENTIFYING LETTER AND MARK WITH NATURE AND MARK OF PROJECTILES HAVE NOT BEEN SHOWN IN FULL IN THE TYPICAL DIAGRAM (*see* SUB-PARA. II.I).

Plate 5 (facing page 25). *Delete* footnote " * CALIBRE " and *substitute* :

Amdt. 2/Oct./1950

* CALIBRE AND MARK STENCILLED ON SEPARATE LOADING SHOT ONLY. IN THE CASE OF FIXED AMMUNITION (LAND SERVICE) IT IS OMITTED, THE NOMENCLATURE BEING INCLUDED IN THE CARTRIDGE MARKING.

NOTE.—CALIBRE, IDENTIFYING LETTER AND MARK, WITH NATURE AND MARK OF PROJECTILE HAVE NOT BEEN SHOWN IN FULL IN THE TYPICAL DIAGRAMS (*see* SUB-PARA. II.I).

Plate 6 (facing page 26) :

Delete all notes under Fig. 6 and *substitute* :

Amdt. 2/Oct./1950

NOTES

+ COMPOSITION CODE. THIS SHOULD BE ON RING ON SHOULDER OF PROJECTILES AS FOR OTHER NATURES, AND NOT AS SHOWN.

(+) COLOUR AS APPLICABLE.

RED, GREEN,

BLUE, YELLOW

STENCILLED IN WHITE.

Add at bottom of plate as a footnote :

Amdt. 2/Oct./1960

NOTE.—CALIBRE, IDENTIFYING LETTER AND MARK, WITH NATURE AND MARK OF PROJECTILE HAVE NOT BEEN SHOWN IN FULL IN THE TYPICAL DIAGRAM (*see* SUB-PARA. II.I).

Plate 7 (facing page 27). *Delete* all notes in centre of plate and *substitute* :

Amdt. 2/Oct./1950

NOTES

+ COMPOSITION CODE. THIS SHOULD BE ON RING ON SHOULDER OF PROJECTILE AS FOR OTHER NATURES, AND NOT AS SHOWN.

(+) COLOUR AS APPLICABLE.

NUMBER OF THE PARACHUTE.

Plate 9 (facing page 31) :

Delete notes under Figs. 9, 10, 11, 12 and *substitute* :

Amdt. 2/Oct./1950

+ COMPOSITION CODE. THIS SHOULD BE ON THE BLACK RINGS ON FIGS 6, 7 AND 9 INSTEAD OF THE PRESENT INDICATED POSITION.

× COLOUR AS APPLICABLE. RED, GREEN, BLUE OR YELLOW.

Add at bottom of plate as a footnote :

Amdt. 2/Oct./1950

NOTE.—CALIBRE, IDENTIFYING LETTER AND MARK WITH NATURE AND MARK OF PROJECTILE HAVE NOT BEEN SHOWN IN FULL IN THE TYPICAL DIAGRAMS (*see* SUB-PARA. II.I).

Plate 10 (facing page 32). *Delete* detail under "NOTES" and *substitute* :

Amdt. 2/Oct./1950

NOTES

+ COMPOSITION CODE. THIS SHOULD BE ON THE LOWER RED RING AND NOT AS SHOWN.

(+) COLOUR AS APPLICABLE.

RED, GREEN, BLUE OR YELLOW.

STENCILLED IN WHITE.

These Amendments have been approved by the Lords Commissioners of the Admiralty, by the Army Council and by the Air Council, and are promulgated for information and guidance.

By Command of their Lordships.

J. G. Lang

By Command of the Army Council.

G. W. S. ...

By Command of the Air Council.

J. H. Barnes

October, 1950.

Oakley 20

NOTE.—THIS SECTION SUPERSEDES SECTION I—PARTS I AND II OF THE
1945 EDITION

Admiralty No. BR1202A47
War Office No. 57/Ammunition/4068
Air Ministry No. A885820/46/D.D. Arm

RESTRICTED

The information given in this document
is not to be communicated, either directly
or indirectly to the Press or to any person
not authorized to receive it.

W.O.
CODE No.
3419

INTER-SERVICE AMMUNITION AND AMMUNITION PACKAGE MARKINGS

1948

SECTION 1

General Introduction

This Section, having been approved by the Lords Commissioners of the Admiralty, by the Army Council and by the Air Council, is promulgated for information and guidance.

By Command of their Lordships.

J. G. Lang

By Command of the Army Council.

Eric B. B. Ford.

By Command of the Air Council.

J. H. Barnes.

CONTENTS

General introduction—	Para.
The marking committee	1
Introduction of new stores	2
The main committee	3
Communications	4
The working sub-committee	5
The purpose of marking	6
The principles of marking... ..	7
Methods of marking	8
Standard colours	9
Markings—variations of	10

PLATE

British Standard colours	Plate I
---------------------------------	------------

INDEX

	Para.	Page
A		
Application—ease of—principles of marking	7.3	6
C		
Clarity and simplicity—principles of marking	7.1	6
Colour markings—method of	8.1	6
Colours—British Standard	9	7
Committee—		
main	3	5
marking	1	5
working sub-committee	5	5
Communications	4	5
Conversion markings	11	7
D		
Departments—production and inspection—		
purpose of marking	6.3	5
E		
Embossing and stamping	8.3	6
I		
Inspection and production departments—		
purpose of marking	6.3	5
Introduction of new stores	2	5
L		
Labels—methods of marking	8.4	6
M		
Main committee	3	5
Marking—		
committee	1	5
methods of	8	6
colour markings	8.1	6
labels	8.4	6
stamping and embossing	8.3	6
stencilling	8.2	6

<i>Marking—contd.</i>	<i>M—contd.</i>	Para.	Page
principles of	7	6
clarity and simplicity	7.1	6
ease of application	7.3	6
uniformity	7.2	6
purpose of	6	5
production and inspection departments	...	6.3	5
the storage and transport services	6.2	5
the user	6.1	5
Markings—			
colour—methods of	8.1	6
Practice, drill, dummy and instructional stores	13	7
Naval—N	12	7
used to indicate conversion, etc.	11	7
variations of	10	7
Methods of marking			
colour markings	8.1	6
labels	8.4	6
stamping and embossing	8.3	6
stencilling	8.2	6
N			
Naval—N marking	12	7
New stores—introduction of	2	5
P			
Principles of marking			
clarity and simplicity	7.1	6
ease of application	7.3	6
uniformity	7.2	6
Production and inspection departments—			
purpose of marking	6.3	5
Purpose of marking			
production and inspection departments	6.3	5
the storage and transport services	6.2	5
the user	6.1	5
S			
Simplicity and clarity—principles of marking			
stamping and embossing	8.3	6
Standard colours used—British standard	9	7
Stencilling—methods of marking	8.2	6
Storage and transport services—purpose of marking	6.2	5
Stores, new—introduction of	2	5
Stores, practice, dummy and instructional—marking of	13	7
Sub-committee—working	5	5
T			
Transport and storage services—purpose of marking	6.2	5
U			
Uniformity—principles of marking			
User—purpose of marking	6.1	5
V			
Variations of markings	10	7
W			
Working sub-committee	5	5

GENERAL INTRODUCTION

1. THE INTER-SERVICE AMMUNITION AND AMMUNITION PACKAGE MARKING COMMITTEE.

By an agreement reached between the Services, a main committee has been formed with the object of allocating marking to ammunition and ammunition packages and standardizing such marking, as far as possible, throughout the three Services.

2. INTRODUCTION OF NEW STORES.

Prior to the introduction of any new ammunition store, the proposed markings to be used on the store will be submitted to the main committee by the Service concerned.

3. THE MAIN COMMITTEE.

The main committee is composed of representatives from the following Service Departments :—

Director General of Artillery (A.2), Chairman.
Director of Ordnance Services (Ord. 20).
Chief Inspector of Armaments.
Director of Armament Supply.
Director General of Armaments (Air).

Representatives from the following attend when necessary :—

Director of Naval Ordnance.
Chief Inspector of Naval Ordnance.
Director of Artillery (G).
Director of Artillery (S.A.).
Director of Underwater Weapons.
Director of Armament Research and Development (Air).
Director of Guided Weapons Research Department.
Director of Equipment, Air Ministry.

4. COMMUNICATIONS.

All communications should be addressed to the Secretary of the Committee, c/o Ministry of Supply.

5. THE WORKING SUB-COMMITTEE.

A working sub-committee deals with the various types of ammunition and packages and submits its recommendations to the main committee for agreement. These recommendations, after agreement, are to be accepted by all concerned.

6. THE PURPOSE OF MARKING

The marking of all natures of ammunition and their packages is essential to ensure quick, correct and sufficient identification at all times for the following reasons :—

- 6.1. *The user* needs general identification as to nature, function and type. He needs detailed identification to ensure correct sorting and, in some instances, he requires instructions on the method of use.
- 6.2. *The storage and transport services* require both general and detailed identification to ensure correct sorting, storage and issue under all conditions of service. This applies not only to new, but also to salvaged ammunition.
- 6.3. *Production and inspection departments* require all forms of identification to ensure that only serviceable ammunition is supplied to the user, also that ammunition subsequently considered suspect can be traced, linked up with its acceptance records and suitably dealt with.

7.

THE PRINCIPLES OF MARKING

The following principles have been observed when deciding the marking of ammunition and ammunition packages :—

Clarity and simplicity ;
Uniformity ;
Ease of application.

7.1. *Clarity and simplicity*

The complete markings for any one store, and its package, consist of the clearest and simplest combination of the methods of marking consistent with easy identification.

Markings required for rapid general identification are made more prominent in size and position than those required for detailed identification.

Special markings to meet some demand of the moment are avoided, except when normal markings are totally inadequate.

7.2. *Uniformity*

7.2.1. Uniformity between the three Services is most desirable to assist common producers, handlers and users.

7.2.2. Uniformity in the application of the methods of marking is maintained wherever practicable within groups of stores of similar characteristics.

The very large number of stores of widely varying operational characteristics, of different sizes and shapes, coupled with the limited number of suitable colours, make uniformity over the whole range impossible and inconsistencies will therefore be found. For example, a ring of certain colour may convey different meanings, depending on the Section in which it appears.

The markings on ammunition cannot always be fully reproduced on ammunition packages, but those markings which do appear will be sufficient readily to identify the contents, consistent with clarity of meaning and simplification of production.

7.3. *Ease of application*

Complicated or excessive markings, superimposed colours, also variations in the sizes of type specified for stencilling, etc., are kept to a minimum.

8.

METHODS OF MARKING

In general, there are four methods of marking ammunition and ammunition packages, and these are based on the foregoing principles. They are :—

8.1. *Colour markings*

These include basic colours that are used to denote the primary nature of the store, e.g., high explosive, practice or incendiary. The area of basic colour exposed is the maximum possible. Additional colour markings, such as rings, stripes and symbols, are used to give further information on the type of filling and its operational and storage characteristics.

The colours selected are vivid and in sharp contrast one to another.

8.2. *Stencilling*

This is used to make identification complete.

8.3. *Stamping and embossing*

Generally, all empty ammunition components are stamped or embossed with certain details relating to the empty store. When filled and assembled, the other methods of marking, such as stencilling, become the means of identification, except for small items such as fuzes and tracers, where stamping is often the only means of identification. Embossing is used for night identification where required.

8.4. *Labels*

The use of paper labels on external packages has been reduced and is replaced by stencilling on the outer packages wherever practicable. Metal tags are, as a rule, employed to convey instructions or warnings to the user.

BRITISH STANDARD COLOURS.



LIGHT BLUE No. 102.



DARK BLUE No. 104.



BROWN No. 411.



LIGHT GREEN No. 225.



DARK GREEN No. 224.
(A.M. GREEN No. 6.)



GREY No. 632.



RED OXIDE No. 446.



RED No. 537.

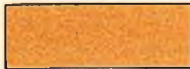

BUFF No. 359.



GOLDEN YELLOW
No. 356.



PINK No. 443.



LIGHT BROWN
No. 410.



STONE No. 361.



DEEP ORANGE
No. 591.

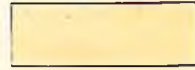

CHAMPAGNE
No. 386.

9. STANDARD COLOURS (Plate 1).

The colours shown throughout this publication conform to the following British Standard Specifications :—

BRITISH STANDARD, 381C, 1947

Light blue	Turquoise No. 102
Dark blue	Azure No. 104
Brown	Middle No. 411
Light green	Light Brunswick No. 225
Dark green	Deep bronze No. 224 (Equals A.M. green No. 6)
Grey	Dark Battleship No. 632
Red oxide	No. 446
Red	Signal No. 537
Buff	Middle No. 359
Golden yellow	Golden No. 356
Pink	Salmon No. 443
Light brown	Light No. 410
Stone	Light No. 361
Orange	Deep No. 590
Champagne	No. 386

BRITISH STANDARD, 987C, 1942

Camouflage brown	No. 2
----------------------	-----	-----	-----	-----	-----	-----	-------

MARKINGS—VARIATIONS OF

10. It should be understood that the markings set out in this publication, in certain cases, vary considerably from past practice. In the first instance, they will be applied to stores for which the designs are sealed subsequent to the date of this publication. Drawings of all current stores will be amended from the date of issue of this publication. All future production of ammunition to existing or to new designs will be marked in accordance with this publication. Existing stocks will be re-marked as and when opportunity offers.
11. Markings used to indicate conversion, repair, examination, etc., of ammunition in the Services (*e.g.*, "RPB" with date and station monogram stencilled on a Land Service projectile to indicate an H.E. filling repaired with beeswax composition) are peculiar to each of the three Services and are not included in the various sections of this publication. Such markings are adopted as the occasion arises in the Service concerned and are introduced by promulgation in the publication, etc., appropriate to the Service. When the store involved is common to one or more other Service, those concerned should also be informed.
12. In Naval Service, the letter N invariably appears as part of the nomenclature. In the case of numbered stores, the letter N prefixes the number. On un-numbered stores it prefixes the Mark, *e.g.*, Mark N 1. Naval stores should not be confused with similar stores in other services bearing the same number.
13. Practice, drill, dummy and instructional stores are defined for marking purposes as follows :—

Practice stores

These can be fired. They differ from operational stores in being specially designed to render them suitable for firing over shortened ranges and/or to limit the damage at the target end.

Drill stores

These cannot be fired. They are used for practising loading or other drill purposes.

Where drill ammunition is made from the material used for the operational store, it will be painted Black. When it is made from material other than that used for the operational store, e.g., wood, rubber, etc., it will be left in its natural state.

Dummy stores

These cannot be fired. They are exact dimensioned replicas of the operational store and can be used for certain functioning tests of the weapon. They have no colour markings and remain in the natural colour of the material from which they are made.

Instructional stores

They may be sectioned or unsectioned items of ammunition. They bear the operational markings, but have the word EMPTY stencilled on them.

NOTE.—THIS SECTION SUPERSEDES SECTION I—PARTS I AND II OF THE
1945 EDITION

Admiralty No. BR 1202B
War Office No. 57/Ammunition/4068
Air Ministry No. A885820/46/D.D.Arm.

RESTRICTED

The information given in this document
is not to be communicated, either directly
or indirectly, to the Press or to any person
not authorized to receive it.

W.O.
CODE No.
3420

INTER-SERVICE AMMUNITION AND AMMUNITION PACKAGE MARKINGS

1948

SECTION 2

Projectiles and Aircraft Bombs

This Section, having been approved by the Lords Commissioners of the Admiralty, by the Army Council and by the Air Council, is promulgated for information and guidance.

By Command of their Lordships.

J. G. Lang

By Command of the Army Council.

Eric B. B. Ford

By Command of the Air Council.

J. H. Barnes

CONTENTS

Introduction—	Para.	Page
Method of colour identification and marking	1	9
Colour markings	2	9
The Red filling ring	3	10
The "Type of filling" ring	4	11
"Method of functioning" rings	5	12
Combination rings	6	12
Special feature rings	7	13
Coloured tips	8	13
Discs and stars	9	13
Markings to indicate special features in projectiles	10	13
Stencilling	11	14
Composite and mixture fillings	12	15
Tracer symbols	13	15
Weight markings	14	15
The series number	15	16
Number of fuze	16	16
Fuze details	17	16
Picric powder exploders	18	16
"K" device	19	16
Coloured smoke	20	16
Projectiles with inert fillings	21	16
Centre of gravity	22	16
Letters or figures—colours	23	17
Letters or figures—size of type	24	17
Letters or figures stencilled on distinguishing rings	25	17
Stampings	26	17
Embossing	27	17
Aircraft bombs—general exceptions	28-30	17
Typical marking on shell filled high explosive	—	18
Projectiles filled high explosive	—	19-22
Markings on shell to denote special features	—	23
Chemical shell	—	24
Piercing projectiles	—	25
Smoke shell	—	26
Practice and miscellaneous projectiles	—	27-28
Base markings on piercing types of shell	—	29
Mortar bombs, 3-inch and above	—	30
Mortar bombs below 3-inch	—	31
Code for smoke, star and incendiary compositions... ..	—	32-33
Code for tracer marking	—	34
Code for tracer fuze marking	—	35
Code for igniter marking	—	36
Code for tracer igniter marking	—	37
Code for dark ignition tracer marking	—	38
Code for dark ignition tracer igniter marking	—	39

LIST OF PLATES

	Plate
Typical marking on shell filled High Explosive	1
Projectiles filled High Explosive	2
Markings on shell to denote special features	3
Chemical shell	4
Piercing projectiles	5
Smoke shell	6
Practice and miscellaneous projectiles	7
Base markings on piercing types of shell	8

	Plate
Mortar bombs 3-inch and above	9
Mortar bombs below 3-inch	10
Aircraft bombs—typical colour markings	11
Aircraft H.E. bombs—filling colour codes	12
Miscellaneous Aircraft bombs—filling colour code	13
Aircraft incendiary bombs—filling colour code	14

INDEX

	Para.	Page
A		
Abbreviations for filling titles	11.3	14
Additional colour markings	2.5	10
Aircraft bombs—general exceptions	28-30	17
B		
Base markings on piercing types of shell	—	29
Body colours	2.1	9
Bombs, mortar—		
3-inch and above	—	9
below 3-inch	—	10
C		
Centre of gravity mark	22	16
Chemical shell	—	24
Code for—		
dark ignition tracer igniter marking	—	39
dark ignition tracer marking	—	38
igniter marking	—	36
smoke, star and incendiary compositions	—	32-33
tracer fuze marking	—	35
tracer igniter marking	—	37
tracer marking	—	34
Colour of letters and figures	23	17
Colour markings	2	9
additional	2.5	10
Coloured—		
rings	2.2	10
smoke	20	16
tips	2.3, 8	10, 13
width	8.1	13
Combination rings	6	12
combination	6.3	12
method of functioning	6.2	12
type of filling	6.1	12
Composite and mixture fillings	12	15
D		
Dark ignition tracer igniter marking—code for	—	39
Dark ignition tracer marking—code for	—	38
Definition of stores	2	9
Details of fuze	17	16
date of filling	17.3	16
FZD	17.1	16
initials of maker	17.4	16
serial number	17.2	16

	D—contd.	Para.	Page
Device "K"		19	16
Discs and stars		2.4, 9	10, 13
inclusion of		9.3	13
presence of		9.1	13
size		9.2	13
E			
Embossing		27	17
Exploders—picric powder		18	16
F			
Figures or letters—			
colour		23	17
size		24	17
stencilled on distinguishing rings		25	17
chemical projectiles		25.2	17
on discs and stars		25.3	17
projectiles other than chemical		25.1	17
Filling ring—Red... ..		3	10
cross-bar-cross ring		3.2	10
hatched ring		3.3	10
plain ring		3.1	10
position of ring		3.4	10
standard width and position—various calibre shell		3.5	10
Filling ring—type of		4	11
chemical projectiles and Aircraft bombs		4.3	11
incendiary projectiles and Aircraft bombs		4.4	11
practice (except Aircraft bombs)		4.5	11
projectiles and Aircraft bombs filled H.E.		4.1	11
smoke projectiles and Aircraft bombs		4.2	11
standard width and position		4.6	11
Filling titles—abbreviations		11.3	14
Fillings—composite and mixture		12	15
Fillings—inert		21	16
Functioning rings		5	12
colour		5.1	12
position		5.3	12
width		5.2	12
Fuze details		17	16
date of filling		17.3	16
FZD		17.1	16
initials of maker		17.4	16
serial number		17.2	16
Fuze number		16	16
G			
General exceptions for Aircraft bombs		28-30	17
Gravity—centre of—markings		22	16
H			
High explosive—			
projectiles—filled with		—	19-22
shell—typical markings		—	18

	I	Para.	Page
Igniter marking—code for	...	—	36
Inert fillings	...	2I	16
Introduction	...	I	9
K			
“ K ” device	...	19	16
L			
Letters or figures—			
colour	...	23	17
size	...	24	17
stencilled on distinguishing rings	...	25	17
chemical projectiles	...	25.2	17
on discs and stars	...	25.3	17
projectiles other than chemical	...	25.1	17
M			
Markings—colour	...	2	9
Markings indicating special features	...	10	13
H.E. shell suitable for fuzeing without additional exploding	...	10.2	14
H.E. shell suitable for proximity fuzes	...	10.3	14
Radar echo	...	10.1	13
Markings on shell to denote special features	...	—	23
Markings—typical—on H.E. shell	...	—	18
Markings—weight	...	14	15
Land service	...	14.1	15
Naval service	...	14.2	16
Method of filling—			
one-line-code	...	11.4	15
“ method of functioning ” rings	...	5	12
colour	...	5.1	12
position	...	5.3	12
width	...	5.2	12
Mixture and composite fillings	...	12	15
Miscellaneous and practice projectiles	...	—	27-28
Mortar bombs—			
below 3-inch	...	—	31
3-inch and above	...	—	30
N			
Number—			
of fuze	...	16	16
series	...	15	16
P			
Picric powder exploders...	...	18	16
Piercing projectiles	...	—	25
Piercing shell—			
base markings	...	—	29
Powder—picric powder exploders	...	18	16
Practice and miscellaneous projectiles	...	—	27-28
Projectiles filled high explosive	...	—	19-22
Projectiles, piercing	...	—	25
Projectiles—			
practice and miscellaneous	...	—	27-28

	R	Para.	Page
Radar echo—markings		10.1	13
Red filling ring		3	10
cross-bar-cross ring		3.2	10
hatched ring		3.3	10
plain ring		3.1	10
position of ring		3.4	10
standard width and position for various calibre shell		3.5	10
Rings, coloured		2.2	10
Rings, combination		6	12
combination		6.3	12
method of functioning		6.2	12
type of filling		6.1	12
Rings, "method of functioning"		5	12
colour		5.1	12
position		5.3	12
width		5.2	12
Rings, Red filling		3	10
cross-bar-cross ring		3.2	10
hatched ring		3.3	10
plain ring		3.1	10
position of ring		3.4	10
standard width and position for various calibre shell		3.5	10
Rings, special feature		7	13
Black rings		7.2, 7.3	13
below driving band... ..		7.5	13
Light Brown ring		7.1	13
Red ring		7.4	13
White ring		7.6	13
Rings—"type of filling"		4	11
chemical projectiles and Aircraft bombs		4.3	11
incendiary projectiles and Aircraft bombs		4.4	11
practice (except Aircraft bombs)		4.5	11
projectiles and Aircraft bombs filled H.E.		4.1	11
smoke projectiles and Aircraft bombs		4.2	11
standard width and position		4.6	11
	S		
Series number		15	16
Shell—			
chemical... ..		—	24
markings on, to denote special features		—	23
piercing—base markings		—	29
smoke		—	26
Shell filled—			
high explosive, typical markings		—	18
Size of type, letters and figures		24	17
below 2-inch calibre		24.4	17
below 4-inch calibre		24.3	17
below 6-inch calibre		24.2	17
6-inch calibre and above		24.1	17
Smoke, coloured		20	16
Smoke, shell		—	26
Smoke, star and incendiary compositions—code for		—	32-33
Special feature markings		10	13
H.E. shell suitable for fuzing without additional exploding		10.2	14
H.E. shell suitable for proximity fuzes		10.3	14
Radar echo		10.1	13

S—contd.

	Para.	Page
Special features—markings on shell to denote	—	23
Special feature rings	7	13
Black rings	7.2, 7.3	13
below driving band... ..	7.5	13
Light Brown ring	7.1	13
Red ring	7.4	13
White ring	7.6	13
Stampings	26	17
Stars and discs	2.4, 9	10,13
inclusion of	9.3	13
presence of	9.1	13
size	9.2	13
Stencilling	II	14
abbreviations of filling titles	II.3	14
calibre and mark	II.1	14
method of filling	II.4	15
code number... ..	II.5	15
type of filling	II.2	14
Stores—definition of	2.1	9
Symbols—tracer	13	15

T

Tips, coloured	2.3, 8	10,13
Tracer fuze markings—code for	—	35
Tracer igniter markings—code for	—	37
Tracer markings—code for	—	34
Tracer symbols	13	15
“Type of filling” rings... ..	4	11
chemical projectiles and Aircraft bombs	4.3	11
incendiary projectiles and Aircraft bombs	4.4	11
practice (except Aircraft bombs)	4.5	11
projectiles and Aircraft bombs filled H.E.	4.1	11
smoke projectiles and Aircraft bombs	4.2	11
standard width and position	4.6	11
Type—size of	24	17
below 2-inch calibre	24.4	17
below 4-inch calibre	24.3	17
below 6-inch calibre	24.2	17
6-inch calibre and above	24.1	17
Typical markings on shell filled H.E.	—	18

W

Weight markings	14	15
Land service	14.1	15
Naval service	14.2	15

INTRODUCTION

1. METHOD OF COLOUR IDENTIFICATION AND MARKING

The methods of marking in this Section conform with those laid down in Section 1, General Introduction, which should be read in conjunction with this Section.

2. COLOUR MARKINGS

These are :—

- The basic body colour.
- Coloured rings.
- Symbols.

2.1. The *basic body colours* indicate the nature of the ammunition store, as follows :—

Colour	In Naval Service		In Land and Air Service	
	Full Title	Abbreviation	Full Title	Abbreviation
Buff*	High effect ...	H.E.	High explosive ...	H.E.
Light Green	Smoke ...	SMK.	Smoke ...	SMK.
Grey	Chemical ...	CHEM.	Chemical ...	CHEM.
Red Oxide...	Incendiary ...	INCDY.	Incendiary ...	INCDY.
White	Star or flare ...	—	Star or flare ...	—
Dark Blue ...	Armour piercing ...	A.P.	High explosive armour piercing.	H.E., A.P.
Light Blue...	Semi armour piercing	S.A.P.	High explosive semi-armour piercing.	H.E., S.A.P.
Red	High effect piercing ...	H.E., P.	High explosive piercing	H.E., P.
Black†	Shot or Practice or Drill, Radar Echo and Miscellaneous.	—	Shot, Practice, Shrapnel, Drill, Paper Shot, Radar Echo and Miscellaneous.	—

NOTES.—Combinations of the above basic colours are employed on stores of composite nature, e.g., Practice ammunition with H.E., Smoke or Chemical filling.

Throughout this Section, coloured parts of stores which have no colour identification significance are depicted in Champagne.

The painting of plugs, where projectiles are issued plugged, is normally no longer required. The plugs will be varnished (*see* para. 10.2).

* Dark Green No. 224 is used instead of Buff for Aircraft bombs and certain Land Service projectiles.

† Aircraft Practice Bombs are painted White.

2.2. Coloured rings

Coloured rings are applied over the basic body colour to indicate :—

- 2.2.1. That the projectile is filled.
- 2.2.2. The type of filling.
- 2.2.3. The method of functioning (when applicable).
- 2.2.4. Special features.

NOTE.—Where the ring is of the same colour as the basic body colour on which it appears, it will be denoted by two Black or White hair lines appropriately spaced, e.g. RDX composition in A.P. shell.

- 2.3. *Coloured tips*
Coloured tips indicate the penetrative qualities of armour piercing shot.
- 2.4. *Discs and stars*
Discs, according to colour, indicate the presence of a Red phosphorus smoke box or flash pellet and stars denote star fillings.
- 2.5. *Other colour markings*
Other colour markings indicate special characteristics of the store not covered by the other markings.

3. THE RED FILLING RING.

This denotes that the store contains an active agent and is normally classified for storage in an Explosives Group.

- 3.1. *A plain Red ring* indicates suitability for issue and storage under all climatic conditions.
- 3.2. *A cross-bar-cross Red ring* indicates a limited life in hot climates.
- 3.3. *A hatched Red ring* denotes restriction of issue and storage to temperate climates only.
- 3.4. *Position of ring.*—These rings are painted on the ogive of the shell. The standard width and exact position according to the calibre, is as follows :—
- 3.5. *Standard width of Red filling ring*
- 3.5.1. *Standard width for projectiles of 3-inch calibre and above, except chemical and mortar bombs*
- | | | |
|---------------------------------|--|---------------------|
| Plain and cross-bar-cross rings | | $\frac{1}{2}$ inch. |
| Hatched ring | $\frac{1}{2}$ inch wide centre ring, with hatch bars of | $\frac{7}{8}$ inch. |
- 3.5.2. *Position*—These are painted on all shell around and 1 inch below the nose.
- 3.5.3. *Standard width for projectiles below 3-inch calibre, except chemical and mortar bombs*
- | | | |
|---------------------------------|--|---------------------|
| Plain and cross-bar-cross rings | | $\frac{1}{4}$ inch. |
| Hatched ring | $\frac{1}{4}$ inch wide centre ring, with hatch bars of | $\frac{1}{2}$ inch. |
- 3.5.4. *Position*—These are painted as near the nose as possible, except that with piercing shot, the ring is immediately below the Dark Blue or Light Blue tip.
- 3.5.5. *Standard width for Aircraft bombs up to 4,000 lb.*
- | | | |
|---------------------------------|--|---------------------|
| Plain and cross-bar-cross rings | | $\frac{1}{2}$ inch. |
| Hatched ring | $\frac{1}{2}$ inch wide centre ring, with hatch bars of | $\frac{7}{8}$ inch. |
- 3.5.6. *Standard width for Aircraft bombs above 4,000 lb.*
- | | | |
|---------------------------------|--|------------------------|
| Plain and cross-bar-cross rings | | 1 inch. |
| Hatched ring | 1 inch wide centre ring, with hatch bars of | $1\frac{3}{4}$ inches. |
- 3.5.7. *Chemical projectiles 3-inch calibre and above*
Standard width of plain Red filling ring $\frac{1}{2}$ inch
- 3.5.8. *Chemical projectiles below 3-inch calibre*
Standard width of plain Red filling ring $\frac{1}{4}$ inch.
- 3.5.9. *Position.*—On projectiles of 4-inch calibre and above the ring is located $\frac{3}{4}$ inch below the container joint. With projectiles below 4-inch calibre it is placed on the nose, starting on the lip of the fuze seating.

- 3.5.10. *Standard width for mortar bombs above 3-inch calibre*
 Plain and cross-bar-cross rings $\frac{1}{2}$ inch.
 Hatched ring $\frac{1}{2}$ inch wide centre ring, with hatch bars of $\frac{1}{4}$ inch.
- 3.5.11. *Standard width for mortar bombs of 3-inch calibre and below*
 Plain and cross-bar-cross rings $\frac{1}{4}$ inch.
 Hatched ring $\frac{1}{4}$ inch wide centre ring, with hatch bars of $\frac{1}{8}$ inch.

NOTES—

- (a) Rings on piercing projectiles will be below the cap or caps when space permits.
 (b) The plain Red filling ring on projectiles, the basic body colour of which is Red, e.g., H.E., P., etc., is indicated by two Black hair lines in the appropriate position. In the case of cross-bar-cross and hatched rings, these will be superimposed on a Black ring, to render them distinguishable from the Red basic body colour.

4. THE "TYPE OF FILLING" RING.

4.1. *For Projectiles and Aircraft Bombs filled H.E.*

- 4.1.1. *Light Green* is the normal colour used for Amatol base fillings, but owing to the limited number of colours, other natures of fillings are also indicated by this ring, e.g., a double standard width ring denotes a Shellite filling.
 4.1.2. *Blue* indicates RDX base fillings.
 4.1.3. *Light Green and Black* indicates TNT base fillings.
 4.1.4. *Light Green-Black-Light Green* indicates Pentolite base fillings.

4.2. *For Smoke projectiles and Aircraft bombs*

- 4.2.1. White Phosphorus.
 4.2.2. Yellow C.S.A.M.
 4.2.3. Red F.M.

4.3. *For Chemical projectiles and Aircraft bombs*

- 4.3.1. *Blister*
 Yellow Y group charging.
 Yellow and Red YR group charging.
 Yellow and White YW group charging.
 Yellow, White and Red YWR group charging.
- 4.3.2. *Choking or nose*
 Light Green G group charging.
 Light Green and White GW group charging.
 Light Green and Light Green GG group charging.
- 4.3.3. *Tear*
 Black B group charging.
 Black and Red BR group charging.

4.4. *Incendiary projectiles and Aircraft bombs*

- White Phosphorus.

4.5. *Practice* (except Aircraft bombs)

- Yellow on Black basic background.

4.6. *Standard widths and position of the "Type of Filling" ring*

Widths—The standard width of the "type of filling" ring varies in proportion to the calibre of the projectile.

4.6.1. *Projectiles* (other than chemical stores and mortar bombs)

Single rings

- Projectiles 6-inch calibre and above 2 inches.
 Projectiles below 6-inch to 3-inch calibre 1 inch.
 Projectiles below 3-inch to 2-inch calibre $\frac{1}{2}$ inch.
 Projectiles below 2-inch to 1-inch calibre $\frac{1}{4}$ inch.

- 4.6.2. *Aircraft bombs*
 Bombs up to 600 lb. 1 inch.
 Bombs from 1,000 to 4,000 lb. 2 inches.
- 4.6.3. *Chemical projectiles or Aircraft bombs*
 Projectiles 6-inch calibre and above 3 inches.
 Projectiles below 6-inch to 4-inch calibre 2 inches.
 Projectiles below 4-inch calibre 1 inch.
- 4.6.4. When there is a variation in the composition of the filling chemical charge, supplementary rings are applied to indicate this. They are half the standard width on projectiles of all calibres.
- 4.6.5. *Mortar bombs*—Where there is not sufficient space, the width of the ring can be as follows :—
 Bombs above 3-inch calibre $\frac{1}{2}$ inch.
 Bombs of 3-inch calibre and below $\frac{1}{4}$ inch.
- 4.6.6. *Position of the "Type of Filling" ring*—The position of the "type of filling" ring is on the shoulder or body of the projectile, except for mortar bombs, when it is on the nose.

5. "METHOD OF FUNCTIONING" RINGS.

These are applied over the basic body colour in addition to the "type of filling" ring, to indicate the "method of functioning" of the projectiles of the carrier type such as smoke, chemical, incendiary, star, etc.

5.1. *Colour of the functioning ring*

White ring denotes	Bursting.
Black ring denotes	Ejection.
Red ring denotes	Emission.

5.2. *Width of "Method of Functioning" rings*

The width of the "method of functioning" rings will be the standard width according to the calibre of the projectile, except where it is a "combination ring" (see para. 6).

5.3. *Position of "Method of Functioning" rings*

The position of the "method of functioning" rings is normally on the shoulder of the projectile, with the exception of the Ejection and Emission rings on Smoke and Incendiary stores. These are placed as follows :—

For forward ejection or emission	On ogive.
For base ejection or emission	On shoulder.
For double ejection	On body.

6. COMBINATION RINGS.

These are used to indicate :—

- 6.1. type of filling,
 6.2. method of functioning,
 or
 6.3. a combination of both.

It is often necessary to use more than one ring on any one projectile to distinguish a "type of filling" and/or "method of functioning". When two or more are so used, they are called combination rings.

Regardless of the number of rings, the top one will always be of standard width on which any stencilling referring to the "type of filling" will be placed. The remainder will always be half the standard width.

The individual coloured rings of a combination will always touch each other except when two adjacent rings are of the same colour, when they will be separated by a half standard width of basic colour.

7. SPECIAL FEATURE RINGS.

7.1. *Light Brown ring*

A Light Brown ring, placed above and adjacent to the Red filling ring indicates a cast-iron projectile. The width of this ring is the same as that for the Red filling ring.

7.2. *Black ring*

A Black ring, the same width as the Red filling ring, and placed immediately above it on H.E. shell, denotes Picric Powder exploders for use with an igniferous fuze.

7.3. *Black ring*

A Black ring, the same width as the Red filling ring and placed immediately below it on H.E. shell, filled other than Lyddite, of calibres up to and including 6-inch, denotes the absence of a smoke producer. Smoke producers are not normally used in H.E. shell of calibre above 6-inch. No marking is necessary to denote this absence in the larger calibre shell.

7.4. *Red ring*

A Red ring, double standard width and placed on the shoulder, indicates shrapnel.

7.5. *Black ring below the driving band*

A Black ring from rear of driving band, extending halfway to base, indicates a projectile of different nominal weight from normal, but of the same nature, when both are fired from the same calibre gun and require a different charge.

7.6. *White ring*

A $\frac{1}{2}$ -inch wide White ring placed in front of the driving band indicates that the projectile is fitted with a cupro-nickel driving band.

8. COLOURED TIPS.

These are used to indicate the penetrative quality of armour-piercing shot :—

Dark Blue denotes armour piercing.

Light Blue denotes semi-armour piercing.

8.1. *Width of coloured tips*

The width of the tips is as follows :—

For projectiles of 3-inch calibre and above 2 inches.

For projectiles below 3-inch calibre 1 inch.

9. DISCS AND STARS.

The inclusion of a Red phosphorus smoke box in H.E. shell or Chemical B.E. shell, is indicated by two Green discs diametrically opposed. With H.E. shell an "A" stencilled on the discs denotes an aluminium box and "B" a bakelite box. The absence of a letter on H.E. shell indicates a steel smoke box. These letters are not used on Chemical B.E. shell, because only a bakelite type of box is used.

9.1. The presence of a star indicates an illuminating projectile.

9.2. The sizes of the discs and stars are as follows :—

9.2.1. On projectiles of 4-inch calibre and above $1\frac{1}{2}$ -inch diameter.

9.2.2. On projectiles below 4-inch calibre *1-inch diameter.

* This may be reduced to $\frac{3}{4}$ -inch diameter when space is restricted.

9.3. The inclusion of a flash pellet is indicated by two aluminium discs, diametrically opposed.

10. MARKINGS TO INDICATE SPECIAL FEATURES IN PROJECTILES

10.1. *Radar Echo projectiles*

To indicate a radar echo projectile a White zig-zag ring of double standard width is placed around the shoulder. For practice projectiles the usual Yellow ring is added.

10.2. *H.E. shell suitable for fuzing without additional exploding*

H.E. shell suitable for fuzing without additional exploding are indicated by having the fuze-hole plug heads painted Light Blue. This applies only to Field Army ammunition.

10.3. *Naval H.E. shell with universal cavities and H.E. shell in Land Service with exploder cavities suitable for taking proximity fuzes*

H.E. shell with exploder cavities suitable for taking proximity fuzes as an alternative to normal fuzes, have two vertical Black stripes ($1\frac{1}{2}$ inches by $\frac{3}{4}$ inch) diametrically opposed on the nose. Shell having a Black basic body colour have two White stripes. These stripes are placed over the rings.

NOTE.—Exceptions to the methods quoted above, necessitated by the introduction of stores having particular characteristics, and the requirements of the Services concerned, are explained in the notes accompanying each illustrative plate.

11. STENCILLING

This is applied over the basic body colour, the coloured rings, or both, and gives such additional information as is necessary to make identification complete. The following are examples of this information :—

II.1. *Calibre and Mark, e.g., 25-pr., Mk. I.* } The Mark is that of the empty
5.5-in. 80-lb., Mk. I. } projectile, whether fixed, separate
7.2-in. How., Mk. I. } or mortar ammunition.

II.2. *Type of filling*

The exact type of an H.E., Smoke, etc., nature of filling is given by abbreviations or code letters and numbers.

Examples :—

(1) RDX/TNT/I indicates a mixture of RDX and TNT in certain proportions and particular grades.

(2) PA are the code letters indicating a PN 443 type of smoke filling.

II.3. *Abbreviations of filling titles*

A	...	Ammonal.
AL	...	Aluminium.
AML	...	Amatol.
AMX	...	Amatex.
B	...	Burrowite.
BAR	...	Baratol.
BWX	...	Beeswax.
CE	...	Composition exploding (Tetryl).
CSAM	...	Chloro-Sulphonic Acid Mixture.
FM	...	Titanium tetrachloride.
LYD	...	Lyddite.
ML	...	Minol.
MNT	...	Monnitrotoluene.
MX	...	Minolex.
PEN	...	Pentolite.
PETN	...	Penta erythritol tetranitrate.
PEN/D	...	Pentolite desensitized.
PE	...	Plastic explosive.
RDX	...	Cyclonite.
SH	...	Shellite.
TNT	...	Trinitrotoluene.
TX	...	Torpex.
WP	...	White phosphorus.

11.4. Method of filling

This information and particulars of filler and date is stencilled in a single horizontal line around the ogive of the projectile; it is called the "one-line-code".

Example:—L10CY1145 where:—

L is for Land Service.

10 is the code number of the method of filling.

CY is the filling contractor's monogram.

1145 is the date of filling (month and year).

11.5. The code number of the method of filling is governed by the details of the initiating system which in H.E. projectiles, for example, has the following main variables:—

11.5.1. Steel or paper exploder containers.

11.5.2. Depth of cavity.

11.5.3. Nature, number and size of exploders or the serial number of the gaine.

11.5.4. In the case of smoke projectiles, the code number indicates details of the powder burster and the nature, number and arrangement of the smoke containers.

The complete code is kept by the Chief Inspector of Armaments and will be issued by him on demand.

The main features of the method of filling design corresponding to the code markings will be available to the Service in Regulations for Army Ordnance Services.

NOTE.—Paras. 11.4 and 11.5 apply to Land Service only.

12. COMPOSITE AND MIXTURE FILLINGS.

A composite filling as opposed to a mixture is indicated by a plus (+) sign, e.g., 808 + PEN 3.

A mixture is indicated by an oblique stroke (/), e.g., RDX/TNT 1.

13. TRACER SYMBOLS.

For details of Tracers see pages 34 to 39.

14. WEIGHT MARKINGS.

14.1. Land Service

14.1.1. Weight markings are applied in accordance with a "Unit System" to a separate loading shell, except Q.F. 12-pr. and 25-pr. shell, star shell and shrapnel shell, the units being based on accuracy requirements for each equipment.

14.1.2. Projectiles within the normal Dead Weight limits of the Range Table Standard are marked with an "O". Where the weight is not within these limits, i.e., plus or minus, the shell is marked with a numeral, prefixed by a plus or minus sign (e.g. + 1 or — 1) to indicate, in terms of units, the variation of weight from the normal. The value of the weight unit varies with the calibre, and may also vary according to the role of the equipment (e.g., Coast Artillery weight units normally indicate finer variations than those used in Field Army Artillery). Dead weight limits are also finer for Coast Artillery projectiles.

14.1.3. The value of a unit in terms of weight is given in the range table in which the correction columns are headed to indicate corrections corresponding to a variation of one weight unit.

14.1.4. Shrapnel shell and Star shell are not weight marked, the former because the weight is adjusted during manufacture, and the latter because accurate ballistics are not so important as for other types.

14.1.5. Fixed Q.F. ammunition used in Anti-Aircraft, Tank or Anti-Tank roles, is not weight marked, and in Coast Artillery the Q.F. 6-pr. 10-cwt. round is not weight marked. The marking is not a requirement in these roles.

14.1.6. The reader should refer to the appropriate range table for the value of the weight unit in connection with any given shell.

- 14.1.7. The position of weight marking is as follows:—
 On projectiles above 6-inch calibre ... Three places equidistant
 around ogive.
 On projectiles 6-inch calibre and below ... In two places, diametrically
 opposed, around ogive.

14.2. *Naval Service*

14.2.1. Naval shell below 3-inch calibre have no weight markings.

14.2.2. *Shell of 3-inch calibre and above*

The original service design in each category of shell supplied for any one calibre gun, has no weight marking.

Subsequent designs of different weights, in the same category and for the same calibre gun, are marked with the appropriate "NOMINAL" weight.

15. THE SERIES NUMBER.

The series number depicted in a ring on projectiles in Land Service, or the filled Lot number in the Naval Service, are used for distinguishing filled series for H.E. and Smoke projectiles, mortar bombs, etc., and the charging series for chemical projectiles.

16. NUMBER OF FUZE.

When a projectile which is issued plugged to the service can be used with one type of fuze only, the following details are stencilled:—

" USE NO. FUZE "

17. FUZE DETAILS.

The following details are stencilled on base fuzed projectiles:—

- 17.1. FZD denoting that the projectile is fuzed.
- 17.2. Serial number of fuze.
- 17.3. Date of filling of the fuze.
- 17.4. Initials of the maker of the empty fuze or the monogram of the converting station.

18. PICRIC POWDER EXPLODERS.

The lot number of the picric powder in the bag is placed on projectiles exploded for use with igniferous fuzes.

19. " K " DEVICE.

The colour of the " K " device is stencilled in full.

20. COLOURED SMOKE.

Projectiles filled with coloured smoke have the colour stencilled in full and NOT by initial letters. This stencilling will be in White.

21. PROJECTILES WITH INERT FILLINGS.

Projectiles having inert fillings, e.g., Practice, weighted, Salt or Sand, etc., have the nature of such inert filling stencilled on the Yellow ring, which denotes practice.

22. CENTRE OF GRAVITY.

Centre of gravity symbols consisting of a horizontal stripe intersecting a circle are applied to projectiles of 2-inch gun (heavy) and above (to facilitate lifting operations during transit and loading). The symbols are stencilled in three places equidistant at the centre of gravity.

The dimensions of the C. of G. symbol are as follows:—

- External diameter of the circle = $2\frac{1}{2}$ inches.
- Thickness of all portions = $\frac{3}{8}$ inch.
- Length of stripes, each = 2 inches.

23. LETTERS OR FIGURES—COLOURS.

These will be as follows :—

- | | |
|--|---------------------------------|
| 23.1. Black on coloured surface | } Except where otherwise shown. |
| 23.2. Red or White on dark surfaces, as applicable | |
| 23.3. White on varnished surfaces | |

NOTE.—Yellow may be used as an alternative to White on a dark background. The Buff basic body colour may be used as an alternative to Black on distinguishing rings over-painted on H.E. stores.

24. LETTERS OR FIGURES—SIZE OF TYPE.

- | | | |
|--|--------|---------------------|
| 24.1. For projectiles 6-inch calibre and above | | $\frac{3}{4}$ inch. |
| 24.2. For projectiles below 6-inch to 4-inch calibre | | $\frac{1}{2}$ inch. |
| 24.3. For projectiles below 4-inch to 2-inch calibre | | $\frac{1}{4}$ inch. |
| 24.4. For projectiles below 2-inch calibre | | $\frac{1}{8}$ inch. |

25. LETTERS OR FIGURES STENCILLED ON DISTINGUISHING RINGS.

The sizes of these will be :—

- | | | |
|--|--------|-----------------------------|
| 25.1. <i>Projectiles other than chemical</i> | | |
| 25.1.1. On rings 1 inch in width and above | | $\frac{3}{4}$ inch. |
| 25.1.2. On rings below 1 inch in width to $\frac{3}{4}$ inch | | $\frac{1}{2}$ inch. |
| 25.1.3. On rings $\frac{3}{4}$ inch in width to $\frac{1}{4}$ inch | | $\frac{1}{4}$ inch. |
| 25.2. <i>Chemical projectiles</i> | | |
| 25.2.1. To indicate unvarnished cavity | | UV |
| 25.2.2. The code indicating the chemical charging. | | |
| The size of type to be stencilled on distinguishing rings for | | |
| all calibres | | $\frac{3}{4}$ inch. |
| 25.3. On discs and stars | | minimum $\frac{1}{4}$ inch. |

26. STAMPINGS

Stampings are used to indicate details of manufacture and inspection of empty projectiles. They are not normally required by the user. The code letter and number of the chemical charging is stamped on chemical shell in addition to the colour marking.

27. EMBOSSING

Embossing may be found on projectiles as in the case of Mortar Bombs, where the nomenclature and Mark may be found embossed on the bodies of cast-iron projectiles.

AIRCRAFT BOMBS—GENERAL EXCEPTIONS

28. The method of marking Aircraft bombs and rockets differs slightly from that used in Naval and Land Services.

Full identification particulars appear on a metal plate permanently affixed to the base or other suitable location on the store. The stencilling of such particulars on coloured shoulder rings, etc., is therefore not employed.

29. Because of camouflage considerations, the normal basic body colour cannot always be applied. In the absence of any specified camouflage scheme, Dark Green, No. 224, will be used.

30. Dark Blue and Light Blue are the specified colours for A.P. and S.A.P. projectiles, but since they are unsuitable colours for Aircraft use, because of camouflage considerations, they can be only partially applied. The basic body colour of these stores will therefore be Dark Green, No. 224.

Piercing qualities are indicated as follows :—

A.P.—A Dark Blue tip, extending to the Red filling ring.



S.A.P.—A Light Blue tip extending to the Red filling ring.

TYPICAL MARKING ON SHELL FILLED HIGH EXPLOSIVE

(Plate 1)

Fig. No.	Class or nature of filling	Code letters and numbers stencilled on rings	Remarks
1	High Effect Shell (N) ...	As applicable (see Plate 2)	H.E. Base and Nose Fuzed (Naval) Shell have the word "TIME" stencilled on the cap when a time fuze is fitted.
2	S.A.P./B.C. Shell (N) ...	,,	
3	High Explosive Shell (L.S.)	,,	
4	H.E., A.P./C, B.C. Shell (L.S.)	,,	

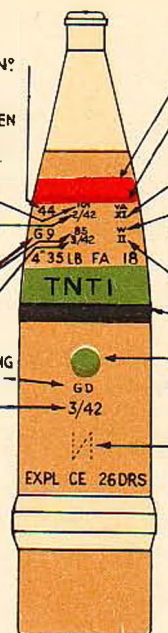
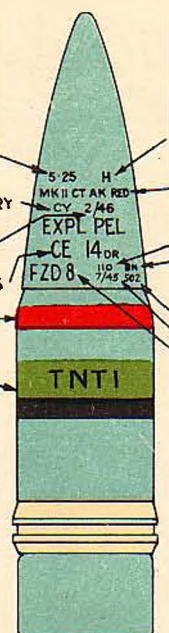
TYPICAL MARKING ON SHELL FILLED HIGH EXPLOSIVE.

1. HIGH EFFECT SHELL (NAVAL)	2. S.A.P./B.C. SHELL (NAVAL)
 <p>SERIAL N°</p> <p>FUZE PARTICULARS ONLY REQUIRED WHEN SHELL ARE FUZED N° 360, 18P, 44 & 45P.</p> <p>FILLED LOT N° DATE OF FILLING (MONTH & YEAR)</p> <p>GAINE PARTICULARS SERIAL N° FILLED LOT N° DATE OF FILLING (MONTH & YEAR)</p> <p>MONOGRAM OF FILLING FACTORY DATE OF FILLING (MONTH & YEAR)</p> <p>EXPL CE 26DRS</p> <p>FILLING RING.</p> <p>MONOGRAM OF MAKER OF EMPTY FUZE.</p> <p>MARK.</p> <p>MONOGRAM OF MAKER OF EMPTY GAINE.</p> <p>MARK.</p> <p>TYPE OF FILLING RINGS.</p> <p>GREEN DISC DENOTING THAT STEEL SMOKE BOX IS FITTED.</p> <p>STENCILLED ON REVERSE.</p>	 <p>CALIBRE & MARK AS APPLICABLE.</p> <p>MONOGRAM OF FILLING FACTORY</p> <p>DATE OF FILLING (MONTH & YEAR)</p> <p>EXPLODER DETAILS</p> <p>FILLING RING.</p> <p>TYPE OF FILLING RINGS.</p> <p>HEAVY OR WEIGHT (e.g. 80LB) AS APPLICABLE.</p> <p>AK DEVICE.</p> <p>FUZE DETAILS. FILLED LOT N° MONOGRAM OF MAKER OF EMPTY FUZE.</p> <p>NUMERAL. DATE OF FILLING. SERIAL N°</p>
3. HIGH EXPLOSIVE SHELL (LAND)	4. HIGH EXPLOSIVE A.P./C., B.C. SHELL (LAND)
 <p>FILLING RING.</p> <p>SERIES NUMBER IN RING DISTINGUISHING FILLED SERIES (STENCILLED ON REVERSE).</p> <p>CODE NUMBER OF THE METHOD OF FILLING.</p> <p>72 HOW MK1</p> <p>+2</p> <p>L14 CY 543</p> <p>AML2</p> <p>CALIBRE & MARK AS APPLICABLE. WEIGHT MARKING.</p> <p>MONOGRAM OF FILLING FACTORY.</p> <p>DATE OF FILLING (MONTH & YEAR).</p> <p>TYPE OF FILLING RING.</p>	 <p>CALIBRE & MARK AS APPLICABLE.</p> <p>FUZE LOT NUMBER WEIGHT MARKING. CODE NUMBER OF THE METHOD OF FILLING.</p> <p>MONOGRAM OF FILLING FACTORY</p> <p>FILLING RING.</p> <p>CENTRE OF GRAVITY</p> <p>SERIES NUMBER IN RING DISTINGUISHING FILLED SERIES (STENCILLED ON REVERSE).</p> <p>DATE OF FILLING (MONTH & YEAR).</p> <p>TYPE OF FILLING RINGS.</p>

PROJECTILES FILLED HIGH EXPLOSIVE

(Plate 2)

Fig. No.	Filling	Code letters and numbers stencilled on shoulder or ring	Remarks
1	Lyddite	LYD.	No distinguishing ring is shown on Lyddite fillings.
2	CE	CE	<i>General Notes</i> 1. Naval 4-inch to 5.25-inch shell fitted with 3½ oz. smoke boxes, filled SR388 are indicated by  in two places, diametrically opposite.
3	TNT TNT (grade 1)	TNT/1	
	TNT (grade 2)	TNT/2	
	TNT contaminated with up to 1% RDX.	TNT/3	
	93% TNT (grade 1) 7% Beeswax	TNT/BWX. 1	
4	TNT/CE 55% TNT (grade 1) 45% CE	TNT/CE. 1	
	70% TNT (grade 1) 30% CE	TNT/CE. 2	
	45% TNT (grade 1) 55% CE	TNT/CE. 3	
5	Amatol 40% Am. Nit. 60% TNT (grade 1)	AML. 1	
	50% Am. Nit. 50% TNT (grade 1)	AML. 2	
	60% Am. Nit. 40% TNT (grade 1)	AML. 3	
	70% Am. Nit. 30% TNT (grade 1)	AML. 4	
	72% Am. Nit. 28% TNT (grade 1)	AML. 5	
	80% Am. Nit. 20% TNT (grade 1)	AML. 6	
6	Amatex 51% Am. Nit. 40% TNT (grade 1) 9% RDX	AMX. 1	
7	Ammonal	A	
8	Baratol 10% Bar. Nit. 90% TNT (grade 1)	BAR. 1	
	20% Bar. Nit. 80% TNT (grade 1)	BAR. 2	

PROJECTILES FILLED HIGH EXPLOSIVE—contd.

(Plate 2)

Fig. No.	Filling	Code letters and numbers stencilled on shoulder or ring	Remarks
9	Burrowite	B	
10	Minol 48% TNT (grade 1) 42% Am. Nit. 10% Aluminium powder	ML. 1	
	40% TNT (grade 1) 40% Am. Nit. 20% Aluminium powder	ML. 2	
11	704B 15% TNT (grade 1) 67.5% Am. Nit. 16% Aluminium 0.5% Calcium Stearate 1% Paraffin Wax	704B	
12	RDX 91% RDX (grade 1, 1A, (B) 1, (B) 1A) 9% Beeswax	RDX/BWX. 1	
	91% RDX (grade 2, (B) 2) 9% Beeswax	RDX/BWX. 2	
13	RDX/TNT 60% RDX (grade 1, 1A, (B) 1, (B) 1A) 40% TNT (grade 1)	RDX/TNT. 1	
	60% RDX (grade 2, (B) 2) 40% TNT (grade 1)	RDX/TNT. 2	
	55% RDX (grade 1, 1A, (B) 1, (B) 1A) 45% TNT (grade 1)	RDX/TNT. 3	
	55% RDX (grade 2, (B) 2) 45% TNT (grade 1)	RDX/TNT. 4	
	50% RDX (grade 1, 1A, (B) 1, (B) 1A) 50% TNT (grade 1)	RDX/TNT. 5	
	50% RDX (grade 2, (B) 2) 50% TNT (grade 1)	RDX/TNT. 6	
	40% RDX (grade 1, 1A, (B) 1, (B) 1A) 60% TNT (grade 1)	RDX/TNT. 7	
	40% RDX (grade 2, (B) 2) 60% TNT (grade 1)	RDX/TNT. 8	

PROJECTILES FILLED HIGH EXPLOSIVE—contd.

(Plate 2)

Fig. No.	Filling	Code letters and numbers stencilled on shoulder or ring	Remarks
14	PE. 1 88.3% RDX 11.7% PE oil (type 1)	PE. 1	
	PE. 2 88.3% RDX 11.7% PE oil (type 2)	PE. 2	
	PE. 3 87.7% RDX 10.5% Shell Mex oil 119 0.6% Lecithin 1.2% Carbon black	PE. 3	
15	Torpex 45% RDX 37% TNT (grade 1) 18% Aluminium powder	TX. 1	
	42% RDX 40% TNT (grade 1) 18% Aluminium	TX. 2	
16	Pentolite 50% PETN 50% TNT (grade 1)	PEN. 1	
	75% PETN 25% TNT (grade 1)	PEN. 2	
	25% PETN 75% TNT (grade 1)	PEN. 3	
17	92% { 50% PETN 50% TNT (grade 1) 8% Desensitizer viz:—6.9% Paraffin Wax 1.0% Nitrocellulose 0.1% Lecithin	PEN/D. 1	
18	808 61.5% Nitroglycerine 16% Nitrocellulose 0.5% Calcium Carbonate 22% MNT	808	
19	808 + Pentolite... .. 70% 808 30% { 25% PETN 75% TNT (grade 1)	808 + PEN. 3	No distinguishing rings are shown for double fillings.
20	808 + RDX/TNT 70% 808 30% { 50% RDX 50% TNT (grade 1)	808 + RDX/TNT. 5 or 6	

PROJECTILES FILLED HIGH EXPLOSIVE—contd.

(Plate 2)

Fig. No.	Filling	Code letters and numbers stencilled on shoulder or ring	Remarks
21	851 83% { 50% PETN 50% TNT (grade 1) 14% Dibutyl Phthalate 3% Nitro cotton	851	
22	852 70% 852 30% { 50% RDX 50% TNT (grade 1)	852	
23	Minolex 20% Am. Nit. 40% TNT (grade 1) 20% RDX 20% Aluminium powder	MX. 1	
24	Shellite 60% Trinitrophenol 40% Dinitrophenol	SH. 1	
	70% Trinitrophenol 30% Dinitrophenol	SH. 2	
25	RDX/WAX/AL... .. 67.5% RDX (grade 1 or 1A) 12.5% WAX (paraffin) 20% Aluminium	RDX/AL. 1	

MARKINGS ON SHELL TO DENOTE SPECIAL FEATURES.

1. ABSENCE OF SMOKE MIXTURE OR RED PHOS SMOKE BOX.



2. RED PHOSPHORUS SMOKE BOX.



3. FULLY EXPLODERED READY FOR IGNIFEROUS FUZE.

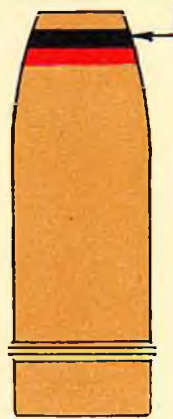

4. CUPRO-NICKEL DRIVING BAND.

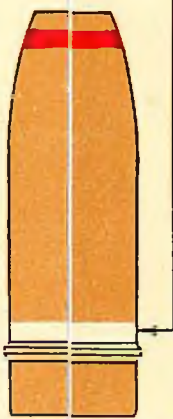

5. GUN PROJECTILE, WHERE A HOWITZER OF THE SAME CALIBRE EXISTS.



6. PROJECTILES OF THE SAME NATURE, BUT OF DIFFERENT NOMINAL WEIGHT FROM THE NORMAL, WHEN FIRED FROM THE SAME GUN AND REQUIRING A DIFFERENT CHARGE e.g. 5-5" BOLB.

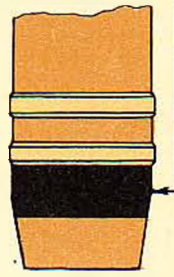

7. H.E. DRILL.

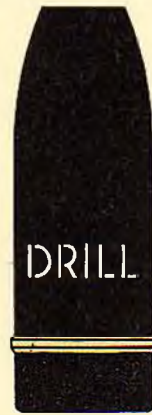

8. CASTIRON OR SEMI-SEEL SHELL.



9. CENTRE OF GRAVITY.

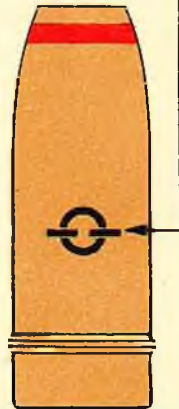

10. TEMPERATE CLIMATES ONLY.

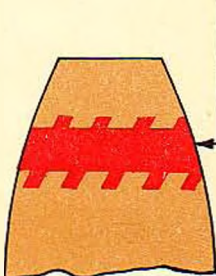

11. LIMITED LIFE IN HOT CLIMATES.

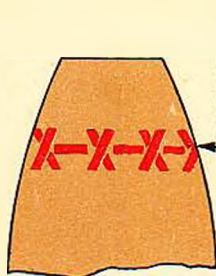

12. EXPLOIER CAVITY SUITBLE FOR PROXIITY FUZE.

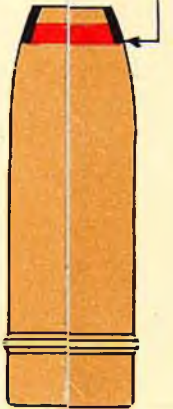



PROJECTILES FILLED HIGH EXPLOSIVE. *								
1. LYDDITE.	2. CE	3. TNT	4. TNT/CE	5. AMATOL.	6. AMATEX.	7. AMMONAL.	8. BARATOL.	9. BURROWITE.
10. MINOL.	11. 704B.	12. RDX	13. RDX/TNT	14. PE	15. TORPEX.	16. PENTOLITE.	17. PENTOLITE (DESENSITIZED)	18. 808.
19. 808 + PENTOLITE.	20. 808+RDX/TNT	21. 851.	22. 852.	23. MINOLEX.	24. SHELLITE.	25. RDX/WAX/AL.		

* FOR CONVENIENCE ALL MARKINGS HAVE BEEN DEPICTED ON H.E. SHELL. THIS METHOD OF MAKING IS ALSO APPLIED TO OTHER PROJECTILES FILLED HIGH EXPLOSIVE.

MARKINGS ON SHELL TO DENOTE SPECIAL FEATURES

(Plate 3)

Fig. No.	Item	Remarks
1	Absence of smoke mixture or Red phosphorus smoke box.	Black ring immediately below Red filling ring.
2	Red phosphorus smoke box	Two Light Green discs diametrically opposed.
3	Fully exploded ready for igniferous fuze	Black ring, same width as Red filling ring, immediately above filling ring.
4	Cupro-nickel driving band	White ring half standard width above the driving band.
5	Gun projectile, where a howitzer of the same calibre exists.	Black ring half standard width above the driving band. Applicable to separate loading ammunition only.
6	Projectiles of the same nature, but of different nominal weight from the normal, when fired from the same gun and requiring a different charge, e.g., 5.5-inch, 80 lb.	Has a Black ring from rear of driving band and extending half way to base (<i>see</i> para. 7.5.).
7	HE drill	Word DRILL is stencilled on shell.
8	Cast-iron or semi-steel shell	Light Brown ring above the Red filling ring.
9	Centre of gravity... ..	Applied to projectiles 9.2-inch gun (heavy) and above (to facilitate lifting operations during transit and loading). Symbol is stencilled in three places equidistant at the C. of G.
10	Shell restricted for use in temperate climates only.	Hatched Red ring on ogive of shell (<i>see</i> para. 3.5.).
11	Shell restricted to a limited life when used in hot climates.	Cross-bar-cross Red ring on ogive of shell (<i>see</i> para. 3.5.).
12	Naval HE shell with universal exploder cavity and Land Service HE shell with exploder cavity suitable for proximity fuze.	Two vertical Black stripes, diametrically opposed on the nose. These stripes are placed over the rings.

CHEMICAL SHELL

(Plate 4)

Fig. No.	Class or nature of filling	Code letter and number stencilled on shoulder or ring	Remarks	Notes
1	Choking or nose	G. followed by figure (s)	G. group	1. The charging code indicates a particular charging within a group (e.g., G1, B4A, Y4). 2. UV. indicates unvarnished cavity. 3. Y. chargings have detector paint at all joints which may be a possible source of leakage, but this paint must not be confused with distinguishing rings or markings.
2	do.	do.	G.W. group	
3	do.	do.	G.G. group	
4	Tear	B. followed by figure (s)	B. group	
5	do.	do.	B.R. group	
6	Blister	Y. followed by figure (s)	Y. group	
7	do.	do.	Y.R. group	
8	do.	do.	Y.W. group	
9	do.	do.	Y.W.R. group	

CHEMICAL SHELL.

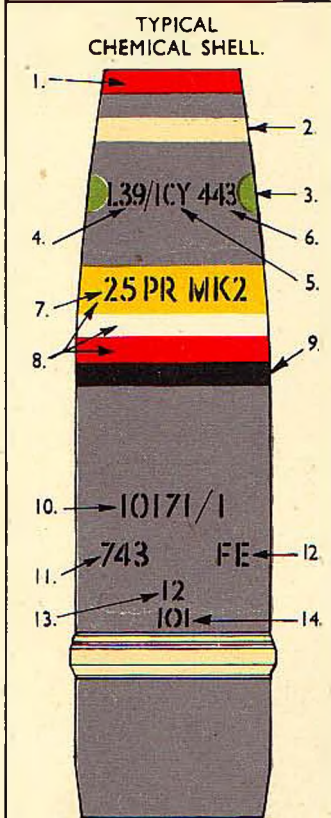

HEAD FILLING.

1. FILLING RING.
2. RING OF DETECTOR PAINT.
3. WHEN FITTED WITH SMOKE BOX.
4. CODE NUMBER OF METHOD OF FILLING. (HEAD FILLING)
5. MONOGRAM OF FIRM OR STATION FILLING.
6. DATE OF FILLING (MONTH & YEAR) HEAD FILLING.
7. CALIBRE AND MARK.
8. TYPE OF FILLING RINGS.
9. BASE EJECTION FUNCTIONING RING.

BODY CHARGING.

10. DESIGN NUMBER OF METHOD OF BODY CHARGING.
 11. DATE OF BODY CHARGING (MONTH & YEAR)
 12. MONOGRAM OF FIRM OR STATION CHARGING BODY
 13. LOT No. OF CHEMICAL CHARGING.
 14. SERIES NUMBER OF CHARGING LOT.
- * CODE NUMBER OF CHARGING.

STENCILLED ON REVERSE

CHOKING OR NOSE.

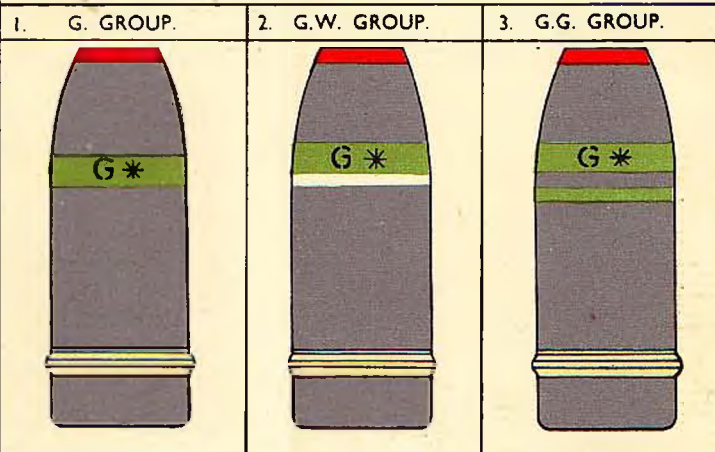

TEAR.

BLISTER.

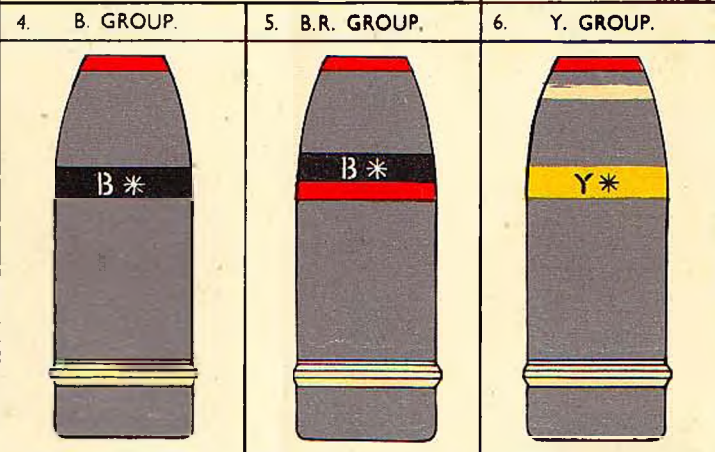

BLISTER.

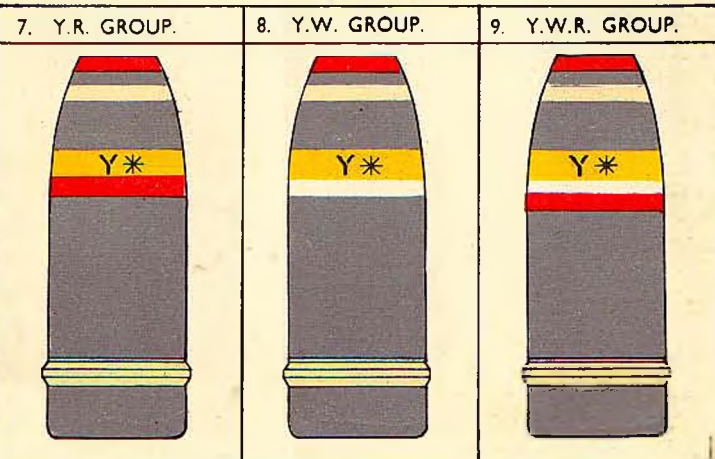

SECTION 2
PLATE 5

PIERCING PROJECTILES.

		SHELL.				
TYPICAL PIERCING SHELL.		1. H.E., P.	2. H.E., P./B.C.	3. H.E., S.A.P. (NAVAL S.A.P)	4. H.E., S.A.P./B.C. (NAVAL S.A.P./B.C)	5. H.E., A.P. (NAVAL A.P.)
<p>1. 6" MK36 FZD LOT12 2. 3. L2/3 CY442 4. 5. TNT/BWX1 6. 7. 8.</p>						
<p>1. CALIBRE AND MARK. 2. LOT NUMBER OF FUZE. 3. SERIES NUMBER IN RING DISTINGUISHING FILLED LOT. 4. CODE NUMBER OF THE METHOD OF FILLING. 5. MONOGRAM OF FIRM OR FILLING STATION. 6. DATE OF FILLING (MONTH & YEAR). 7. FILLING RING. 8. TYPE OF FILLING RING</p>		SHELL.		SHOT		
TYPICAL PIERCING SHOT.		6. H.E., A.P./C., B.C. (NAVAL A.P./C., B.C)	7. H.E., A.P./C. (NAVAL A.P./C)	8. A.P.D.S. OR C.R/T.	9. A.P.S.V/T.	10. S.A.P/T.
<p>1. 2. 25PR 1MK8 3. T 4. L25 CY 541 5. 6.</p>						
<p>1. FILLING RING. (TRACER) * 2. CALIBRE AND MARK. 3. TRACER SYMBOL. 4. CODE NUMBER OF THE METHOD OF FILLING 5. MONOGRAM OF FILLING FIRM 6. DATE OF FILLING (MONTH & YEAR).</p>		SHOT				
		11. A.P./T.	12. A.P./C/T	13. A.P./C., B.C/T.		
		<p>NOTES. + K OR AK WHERE APPLICABLE. X COLOUR AS APPLICABLE. RED. GREEN. BLUE. YELLOW. WHITE.</p>				

* CALIBRE AND MARK STENCILED ON SEPARATE LOADING SHOT ONLY.

PIERCING PROJECTILES

















(Plate 5)

Fig. No.	Class or nature of filling	Remarks
1	<i>SHELL</i> H.E., P. (N.L.A.)	} See para. 2.1. for N.S. nomenclature. The Red filling ring to be indicated by the painting of two fine Black hair lines on the shoulder.
2	H.E., P./B.C. (N.L.A.)	
3	H.E., S.A.P. (Naval S.A.P.)	
4	H.E., S.A.P./B.C. (Naval S.A.P./B.C.)	Projectiles when fitted with a "K" or "AK" device have these letters followed by the colour in words stencilled on the ballistic cap.
5	H.E., A.P. (Naval A.P.)	
6	H.E., A.P./C., B.C. (Naval A.P./C., B.C.)	
7	H.E., A.P./C. (Naval A.P./C.)	
8	<i>SHOT</i> A.P.D.S. or C.R./T.	Red ring in this instance denotes presence of tracer filling.
9	A.P.S.V./T.	Red ring in this instance denotes presence of tracer filling. The single White ring denotes that the projectile is suitable for use through a squeeze bore attachment, and only projectiles bearing that marking can be so used.
10	S.A.P./T.	
11	A.P./T.	
12	A.P./C./T.	
13	A.P./C., B.C./T.	

SMOKE SHELL

(Plate 6)

Fig. No.	Class or nature of filling	Code letter and number stencilled on shoulder or ring	Remarks
1	Ejection, screening ...	Composition code	1. Composition code to be stencilled on or above rings to indicate nature of smoke mixture in ejection and emission types. 2. Coloured smoke to be indicated by colour stencilled in White in full :— Red. Green. Blue. Yellow.
2	Ejection, coloured ...	Composition code plus colour in White.	
3	Emission, screening ...	Composition code.	
4	Bursting, WP	—	
5	<i>PRACTICE</i> Target, smoke, bursting, WP.	—	
6	Smoke, bursting, FM	—	

PRACTICE AND MISCELLANEOUS PROJECTILES.							
PRACTICE.							
1. WEIGHTED.	2. BREAK UP.	3. POWDER-FILLED	4. SMOKE, BURSTING, F M	5. WITH FLASH PRODUCER.	6. FOR REDUCED CHARGE.	7. FLATHEAD SHOT/T.	
							
PRACTICE.						TARGET.	
8. BOMBARDMENT	9. TARGET, SMOKE, BURSTING W P					10. BACK FIRING, (BE)	11. FALLING, (BE)
							
INCENDIARY.		STAR.		FLARE	SHRAPNEL.		
12. BASE EJECTION.	13. BURSTING.	14. WITH PARACHUTE.	15. NON-PARACHUTE TYPE.	16. TARGET RECOGNITION, B E	17. SHRAPNEL.		
							

NOTES.
+ COMPOSITION CODE.
⊕ COLOUR AS APPLICABLE.
NUMBER OF THE PARACHUTE

SMOKE SHELL.

TYPICAL SMOKE SHELL.

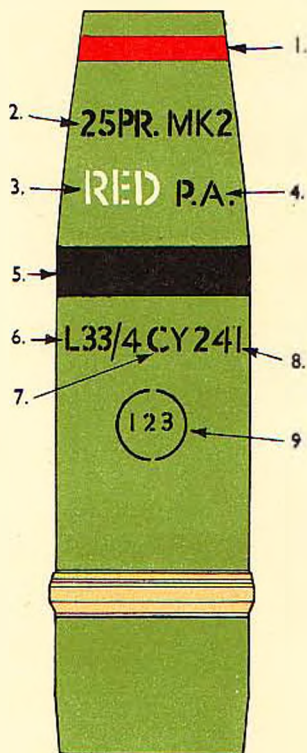

1. FILLING RING.
2. CALIBRE & MARK AS APPLICABLE.
3. COLOUR OF SMOKE COMPOSITION AS APPLICABLE.
4. COMPOSITION CODE.
5. BASE EJECTION FUNCTIONING RING.
6. CODE NUMBER OF THE METHOD OF FILLING.
7. MONOGRAM OF FIRM OR STATION FILLING.
8. DATE OF FILLING (MONTH & YEAR).
9. SERIES NUMBER IN RING DISTINGUISHING FILLED LOT.

EJECTION.

1. SCREENING.



2. COLOURED.



EMISSION.

3. SCREENING.



BURSTING.

4. W P



PRACTICE

5. TARGET, SMOKE, BURSTING W P



6. SMOKE, BURSTING, F M



NOTES.
+ COMPOSITION CODE.
⊕ COLOUR AS APPLICABLE.
RED.
GREEN.
BLUE.
YELLOW.
STENCILLED IN WHITE.

PRACTICE AND MISCELLANEOUS PROJECTILES

(Plate 7)

Fig. No.	Class or nature of filling	Code letters and number stencilled on shoulder or ring	Remarks
1	<i>PRACTICE</i> Weighted	—	Nature of filling to be stencilled on Yellow ring (L.S. only).
2	Break up	—	Indicated by a broken Yellow ring, half standard width, below the Yellow ring, a half standard width of the basic body colour between the two rings.
3	Powder filled	—	
4	Smoke, bursting, FM	—	
5	With flash producer...	—	Two aluminium discs diametrically opposed denote presence of flash producer.
6	For reduced charge ...	RED in White (L.S. only)	RED (stencilled above the Yellow ring) indicates that the projectile is restricted and <i>must not</i> be fired with a full charge.
7	Flathead shot/T ...	—	
8	Bombardment ...	—	
9	Target, smoke, bursting, WP.	—	
10	<i>TARGET</i> Back firing, BE ...	—	White zig-zag ring, and the usual Yellow ring denoting practice near head, with "BF" at three intervals on the White ring.
11	Falling, BE	—	White zig-zag ring near head and the Yellow ring to denote practice.
12	<i>INCENDIARY</i> Base ejection ...	—	Composition code.
13	Bursting	—	The chargings of composition fillings are indicated by the code number for the charging or composition stencilled immediately below the functioning ring.

PRACTICE AND MISCELLANEOUS PROJECTILES—*contd.*

(Plate 7)

Fig. No.	Class or nature of filling	Code letters and numbers stencilled on shoulder or ring	Remarks
14	<i>STAR</i> With parachute ...	Composition code	" P ", followed by a code number, indicates the shell is fitted with a parachute. the code number indicating type of parachute.
15	Non-parachute type...	do.	" NP " indicates no parachute.
16	<i>FLARE</i> Target recognition BF	Colour to be stencilled in full in ¾-inch type on ogive.	Black ring to indicate functioning. Colour in words indicating nature.
17	<i>SHRAPNEL</i>	—	Has a double standard width Red ring on the shoulder.

BASE MARKINGS ON PIERCING TYPES OF SHELL
INDICATING DELAY, NON-DELAY OR OPTIONAL DELAY AND
TYPE OF FUZE

(Plate 8)

VIEWS SHOWING COLOURS ON BASE OF PROJECTILE

Fig. No.	Fuze action obtainable	Markings		Types of fuzes indicated	Remarks
		Cover plate	Screwed ring		
1	Non-delay	Red	Red	No. 16.	
2		Red with Light Green bar $\frac{1}{2}$ inch wide.	do.	Nos. 500, 501.	
3		Red with White bar $\frac{1}{2}$ inch wide.	do.	No. 551.	
4	Delay	Red with Dark Blue border $\frac{1}{2}$ inch wide.	do.	No. 16D.	
5		Red with Dark Blue border $\frac{1}{2}$ inch wide.	White	Nos. 158, 158A or 159.	Fuzes designed for optional delay action, but restricted to delay action by earlier type of cover plate which has no optional delay setting plug.
6		do.	Yellow	Nos. 345, 345A or 346.	
7		do.	Dark Blue	Nos. 479, 479A or 480.	
8	Optional delay.	Red with setting plug unpainted.	do.	Nos. 158A, 159, 345A, 346, 479A or 480.	Fuzes designed for optional delay in conjunction with a cover plate* incorporating delay setting plug.
9		Red with setting plug unpainted and with a Light Green bar $\frac{1}{2}$ inch wide.	do.	Nos. 158, 345 or 479.	

* When a disc-type of tracer is used in place of the cover plate in the base of the shell, the tracer will bear the marking normally placed on the cover plate, the non-delay set screw in the tracer being left unpainted.

MORTAR BOMBS, 3-INCH AND ABOVE

(Plate 9)

Fig. No.	Class or nature of filling	Code letters and numbers stencilled on rings	Remarks
1	HE Amatol 60% Am. Nit. ... 40% TNT (grade 1)	AML. 3	
	70% Am. Nit. 30% TNT (grade 1)	AMI. 4	
2	70% Am. Nit. 30% TNT (grade 1)	AML. 4	
	72% Am. Nit. 28% TNT (grade 1)	AML. 5	
	80% Am. Nit. 20% TNT (grade 1)	AML. 6	
3	Smoke, bursting, FM ...	—	Red ring denotes FM. Yellow ring denotes CSAM. White ring denotes WP.
4	Smoke, bursting, CSAM	—	
5	Smoke, bursting, Phos.	—	
6	Coloured smoke, BE ...	PA, QA, RA or UA, as applicable, above Black ring.	
7	Smoke, BE ...	Composition code, as applicable, above Black ring.	
8	Radar Echo, BE ...	—	
9	Flare, BE ...	Flare colour and composition code above Black ring.	
10	Powder filled, Practice	—	
11	Chemical, bursting ...	Y ₃ or B ₄ as applicable. UV stencilled in two places for unvarnished bombs.	Detector rings shown at X (Fig. 12) apply to Y chargings only. The White ring indicating bursting is not adjacent to the Yellow ring denoting "type of filling" and has been made full standard width clearly to distinguish it from the combination ring denoting YW group (see Plate 4, Fig. 8).
12	Practice ...	—	"Type of filling" ring for CAL.C has not been allotted as the charging is unlikely to be perpetuated. The original method of marking has therefore remained unaltered.
13	Smoke, BE skytrail, R, G, Y and B.	—	

BASE MARKINGS ON PIERCING TYPES OF SHELL.

FUZED FOR NON-DELAY ACTION.

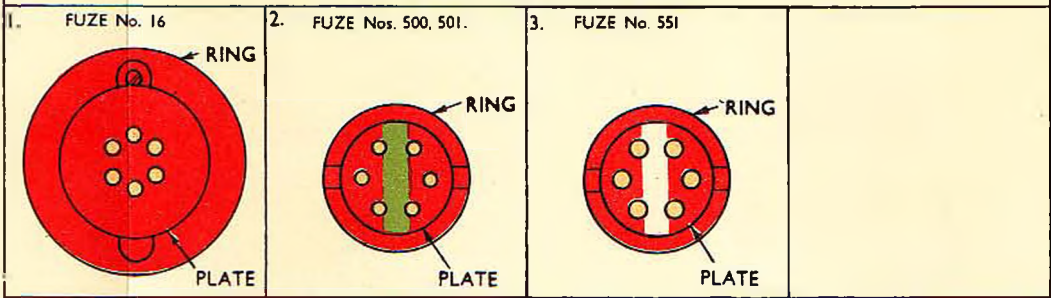

FUZED FOR DELAY ACTION.

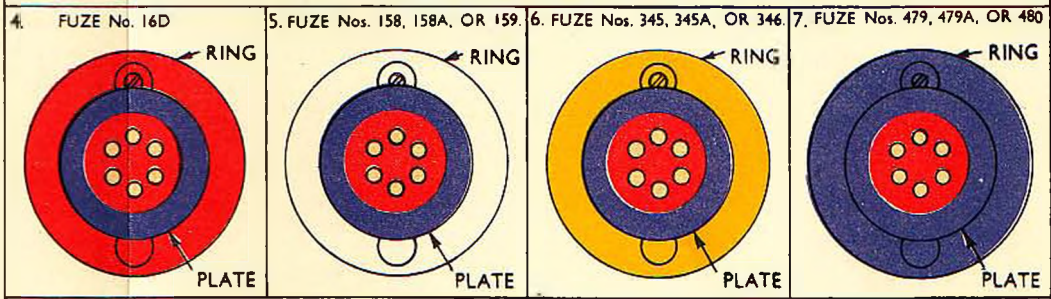

FUZED FOR OPTIONAL DELAY OR NON-DELAY ACTION.

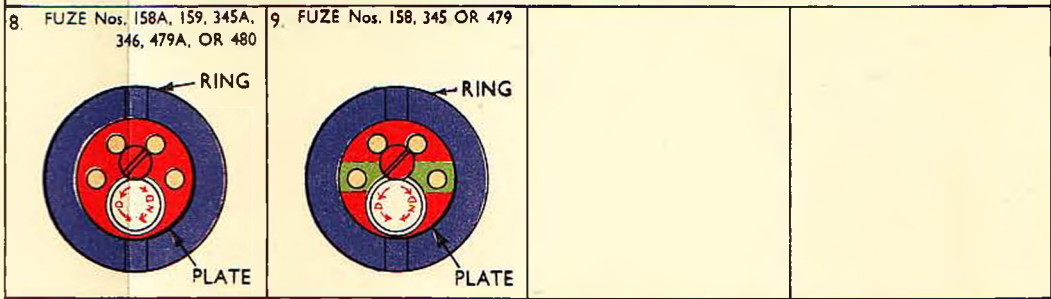

THE ABOVE FIGS. SHOW ONLY THE PERFORATED COVER PLATE SURROUNDED BY IT'S SCREWED RING. FOR CERTAIN FUZES THE COVER PLATE IS NOT PERFORATED. THE REMAINDER OF THE BASE OF THE SHELL IS PAINTED IN THE BASIC COLOUR APPROPRIATE TO THE NATURE. A COMPLETE VIEW OF TYPICAL BASE MARKING IS GIVEN BELOW.

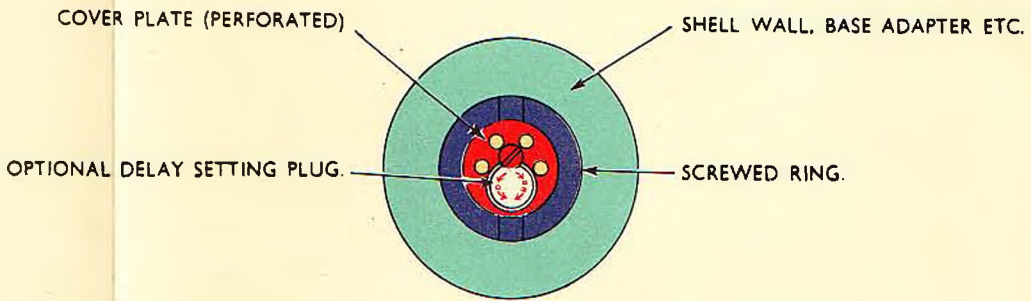

MORTAR BOMBS 3-INCH AND ABOVE.

TYPICAL H.E. BOMB.

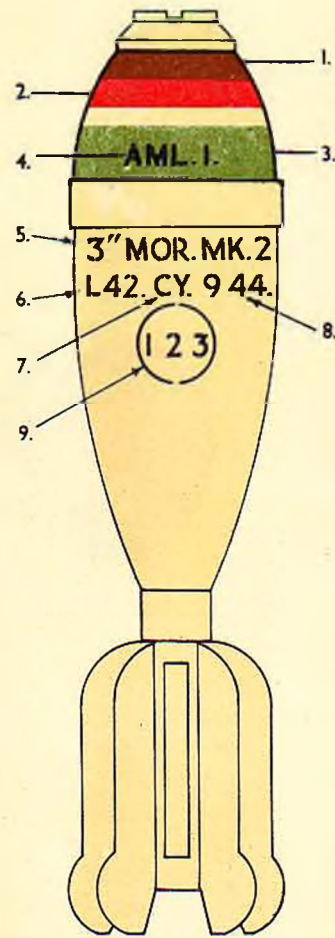

1. RING DENOTING CAST IRON BOMB.
2. FILLING RING.
3. TYPE OF FILLING RING.
4. CODE NUMBER OF THE TYPE OF FILLING.
5. CALIBRE & MARK AS APPLICABLE.
6. CODE NUMBER OF THE METHOD OF FILLING.
7. MONOGRAM OF FIRM OR STATION FILLING.
8. DATE OF FILLING (MONTH & YEAR).
9. SERIES NUMBER IN RING DISTINGUISHING FILLED SERIES.

TYPICAL SMOKE BURSTING BOMB.

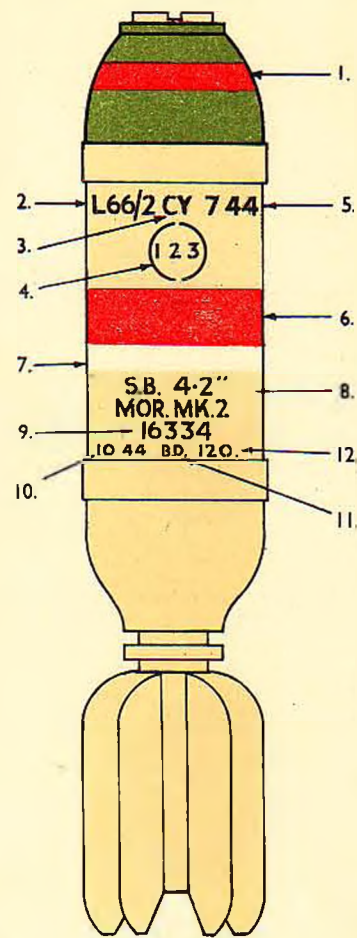

- HEAD FILLING.
1. FILLING RING.
 2. CODE NUMBER OF THE METHOD OF FILLING.
 3. MONOGRAM OF FIRM OR STATION FILLING.
 4. SERIES NUMBER IN RING DISTINGUISHING FILLED LOT (STENCILLED ON REVERSE).
 5. DATE OF FILLING (MONTH & YEAR).
 6. TYPE OF FILLING RING.
 7. BURSTING FUNCTIONING RING.
 8. CALIBRE & MARK.
- BODY CHARGING.
9. DESIGN NUMBER OF CHARGING.
 10. DATE OF CHARGING (MONTH & YEAR).
 11. MONOGRAM OF FIRM OR STATION CHARGING.
 12. CHARGING LOT NUMBER.

TYPICAL CHEMICAL BOMB.

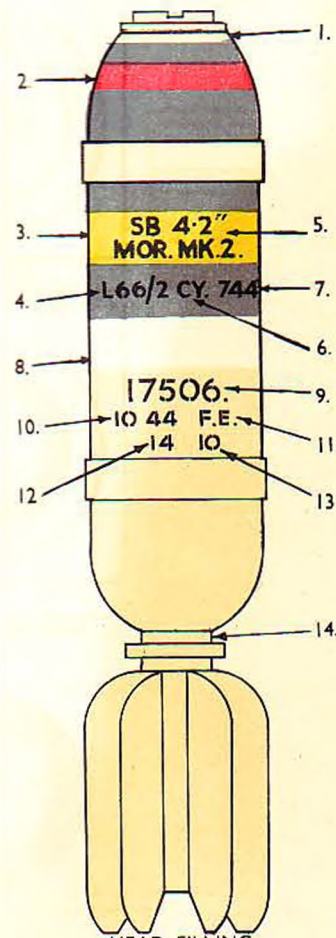

- HEAD FILLING.
1. RING OF DETECTOR PAINT.
 2. FILLING RING.
 3. TYPE OF FILLING RING.
 4. CODE NUMBER OF THE METHOD OF FILLING.
 5. CALIBRE AND MARK.
 6. MONOGRAM OF FIRM OR STATION FILLING.
 7. DATE OF FILLING (MONTH & YEAR).
 8. BURSTING FUNCTIONING RING: BODY CHARGING.
 9. DESIGN NUMBER OF CHARGING.
 10. DATE OF CHARGING (MONTH & YEAR).
 11. MONOGRAM OF FIRM OR STATION CHARGING.
 12. CHEMICAL CHARGING LOT NUMBER.
 13. SERIES NUMBER OF CHARGING LOT.
 14. RING OF DETECTOR PAINT.

1. H.E. AMATOL.	2. H.E. AMATOL (C.I. BOMB)	3. SMOKE, BLUSTING, F M	4. SMOKE, BURSTING, C S A M	5. SMOKE, BURSTING, PHOS.	6. COLOURED SMOKE, B E	7. SMOKE, B E
8. RADAR ECHO, B E	9. FLARE, B E	10. POWDER FILLED, PRACTICE (C.I. BOMB)	11. CHEMICAL, BURSTING.	12. PRACTICE, CHEMICAL.	13. SMOKE, B E SKYTRAIL.	







+ COMPOSITION CDE. X COLOUR AS APPLICABLE RED, GREEN, BLUE OR YELLOW.

MORTAR BOMBS BELOW 3-INCH

(Plate 10)

Fig. No.	Class or nature of filling	Code letters and numbers stencilled on rings	Remarks
1 ...	Baratol	BAR followed by code figure (s).	
2	Amatol	AML followed by code figure (s).	
3	Smoke, bursting, WP ...	—	
4	Smoke, emission ...	FE or M.	
5	Coloured smoke, emission	PA, PJ, QA or RA	Smoke colour, Red, Green, Blue or Yellow stencilled on body in White.
6	Practice	—	Red filling ring denotes presence of live cartridge with this inert bomb.

MORTAR BOMBS BELOW 3-INCH.

1. BARATOL.	2. AMATOL.	3. SMOKE, BURSTING, WP	4. SMOKE, EMISSION.
			
<p>5. COLOURED SMOKE, EMISSION.</p>	<p>6. PRACTICE.</p>		
			<p>NOTES. + COMPOSITION CODE. ⊕ COLOUR AS APPLICABLE. RED GREEN. BLUE. YELLOW. STENCILLED IN WHITE.</p>





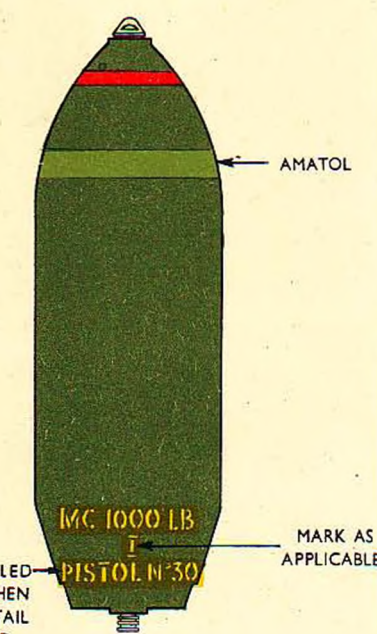
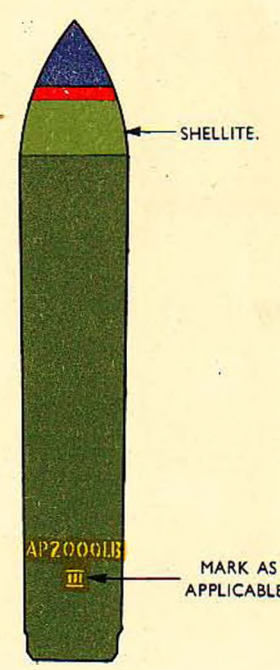

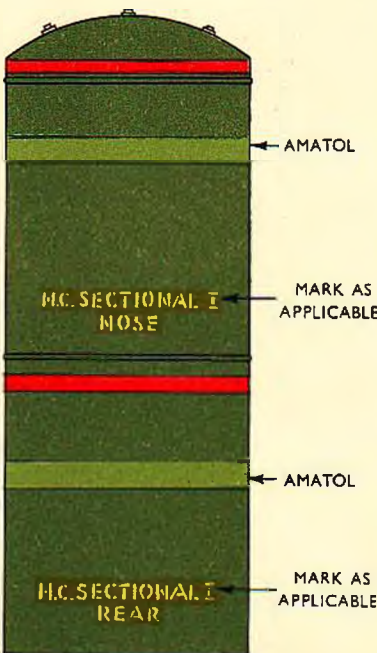
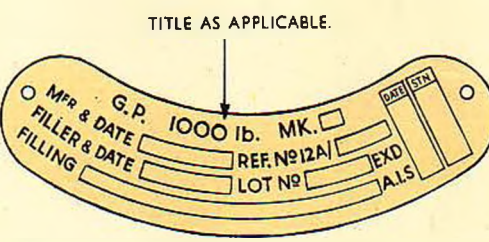
VARNISH FOR H.E MORTAR BOMBS IS REGARDED AS AN EQUIVALENT TO BUFF BASIC COLOUR.

AIRCRAFT BOMBS-TYPICAL COLOUR MARKINGS.





<p>1. H.E.</p>  <p>AMATOL</p> <p>MC 1000 LB PISTOL N°30</p> <p>TO BE STENCILLED ON ONLY WHEN PISTOL BOMB TAIL No. 30. IS FITTED</p> <p>MARK AS APPLICABLE.</p>	<p>2. H.E., A.P.</p>  <p>SHELLITE.</p> <p>AP2000LB III</p> <p>MARK AS APPLICABLE.</p>
---	---

<p>3. H.E. SECTIONAL.</p>  <p>AMATOL</p> <p>H.C. SECTIONAL I NOSE</p> <p>MARK AS APPLICABLE.</p> <p>AMATOL</p> <p>H.C. SECTIONAL I REAR</p> <p>MARK AS APPLICABLE.</p>	<p>IDENTIFICATION PLATE.</p>  <p>TITLE AS APPLICABLE.</p> <p>G.P. 1000 lb. MK. <input type="checkbox"/></p> <p>MFR & DATE <input type="text"/> REF. N°12A/ <input type="text"/></p> <p>FILLER & DATE <input type="text"/> LOT N° <input type="text"/> EXD <input type="text"/></p> <p>FILLING <input type="text"/> ALS <input type="text"/></p> <p>DATE <input type="text"/> STN <input type="text"/></p>
---	---

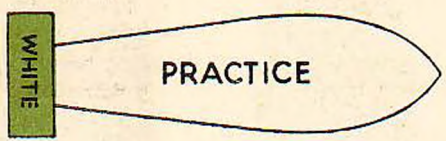

AIRCRAFT H.E. BOMBS,-FILLING COLOUR CODE.

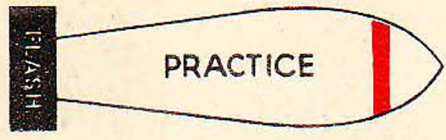
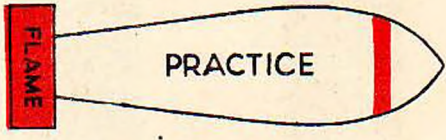
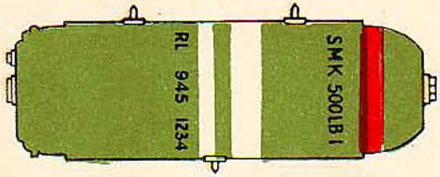
1. SHELLITE.	2. TNT	3. AMATOL, MINOL OR AMATEX.	4. RDX/TNT OR TORPEX.
			
5. PENTOLITE.	6. TEMPERATE CLIMATES ONLY.	7. LIMITED LIFE IN HOT CLIMATES.	
			

MISCELLANEOUS AIRCRAFT BOMBS-FILLING COLOUR CODE.

<p>1. PRACTICE WHITE SMOKE.</p> 	<p>2. PRACTICE BROWN SMOKE.</p> 
<p>3. PRACTICE FLASH.</p> 	<p>4. PRACTICE FLAME.</p> 
<p>5. 500 LB SMOKE BURSTING W P</p> 	<p>6. 500 LB SMOKE B E</p> 
<p> </p>	<p> </p>

AIRCRAFT INCENDIARY BOMBS-FILLING COLOUR CODES.

1. 4lb. NON-DELAY/NON EXPLOSIVE.	2. 4lb. EXPLOSIVE WITH DELAY.
	

CODE FOR SMOKE, STAR AND INCENDIARY COMPOSITIONS

(Not applicable to Air Service stores)



Code	Composition	Code	Composition	Code	Composition
B	S.R. 269 and P.N. 83	NC	S.R. 568A	KF	S.R. 429A and S.R. 568A
C	S.R. 269	OC	S.R. 580	LF	S.R. 406 and S.R. 568A
D	S.R. 264A	PC	S.R. 580A	MF	S.R. 413 and S.R. 429
E	P.N. 83	QC	S.R. 581A	NF	S.R. 429 and S.R. 429A
F	P.N. 279	UC	S.R. 588	OF	S.R. 406 and S.R. 429
G	P.N. 280	WC	S.R. 238	PF	S.R. 415 and S.R. 427A
H	P.N. 281	AD	S.R. 424	RF	S.R. 406 and S.R. 427A
J	P.N. 282	BD	S.R. 431	SF	S.R. 406, S.R. 413 and S.R. 568A
M	P.N. 303	DD	S.R. 307A	TF	S.R. 406, S.R. 429A and S.R. 568A
O	S.R. 223C	ED	S.R. 571	UF	S.R. 413, S.R. 429A and S.R. 568A
P	S.R. 264A and S.R. 269	GD	S.R. 391	WF	S.R. 406, S.R. 413 and S.R. 429
S	S.R. 264B and S.R. 264D	HD	S.R. 452	YF	S.R. 406, S.R. 429 and S.R. 429A
T	S.R. 905	JD	S.R. 453	ZF	S.R. 413, S.R. 429 and S.R. 429A
U	S.R. 907	KD	S.R. 454	AG	S.R. 239, S.R. 491 and S.R. 584
W	S.R. 332B	LD	S.R. 578	BG	S.R. 214, S.R. 232, S.R. 237, S.R. 288, S.R. 477B, S.R. 562 and Rocket compo.
Y	S.R. 321 and S.R. 322	MD	S.R. 481	CG	S.R. 297B, S.R. 406 and S.R. 413
Z	S.R. 899	ND	S.R. 586	DG	S.R. 297B, S.R. 406 and S.R. 429A
BA	S.R. 264C	OD	S.R. 594M	EG	S.R. 297B, S.R. 413 and S.R. 429A
CA	S.R. 306	PD	S.R. 343A	GG	P.N. 61
EA	S.R. 306B	QD	S.R. 563A	JG	P.N. 118
GA	S.R. 563	TD	S.R. 255	KG	P.N. 276
MA	S.R. 375	UD	S.R. 365	MG	P.N. 307
OA	S.R. 562	ZD	S.R. 379	NG	P.N. 307A
PA	P.N. 443	AE	S.R. 382	OG	P.N. 314A
QA	P.N. 431A	DE	S.R. 400	PG	P.N. 314
RA	P.N. 435	EE	S.R. 269(M) and P.N. 83(M)	QG	P.N. 317
UA	P.N. 497	FE	S.R. 269(M)	RG	S.R. 361
YA	S.R. 534	GE	S.R. 264A(M)	SG	S.R. 332
ZA	S.R. 232	JE	P.N. 83(M)	TG	S.R. 581
AB	S.R. 287	KE	S.R. 264A(M) and S.R. 269(M)	UG	S.R. 590
CB	S.R. 297B	LE	P.N. 402	WG	S.R. 223B
DB	S.R. 300A	ME	P.N. 403	YG	S.R. 512B
EB	S.R. 338	NE	S.R. 232 and S.R. 590	ZG	S.R. 442
FB	S.R. 475	OE	S.R. 232 and S.R. 429	AH	S.R. 576A
GB	S.R. 477A	PE	S.R. 232 and S.R. 428	BH	S.R. 562A
HB	S.R. 479A	QE	S.R. 232 and S.R. 413	CH	S.R. 541B
JB	S.R. 565	SE	S.R. 238 and S.R. 389	DH	S.R. 274B
KB	S.R. 209	TE	S.R. 255 and S.R. 297B	EH	S.R. 430
MB	S.R. 209A	YE	S.R. 209A and S.R. 415	FH	Calcium Phosphide
NB	S.R. 221	ZE	S.R. 239 and S.R. 578		
PB	S.R. 221B	AF	S.R. 357 and S.R. 481		
RB	S.R. 571A	BF	S.R. 297B and S.R. 413		
TB	S.R. 237	CF	S.R. 297B and S.R. 429A		
UB	S.R. 297C	DF	S.R. 297B and S.R. 406		
WB	S.R. 367	EF	S.R. 329 and S.R. 460		
YB	S.R. 389	FF	S.R. 329 and S.R. 427		
ZB	S.R. 406	GF	S.R. 427 and S.R. 429		
BC	S.R. 427	HF	S.R. 413 and S.R. 428		
DC	S.R. 427A	JF	S.R. 513 and S.R. 568A		
EC	S.R. 428				
GC	S.R. 429				
HC	S.R. 429A				
JC	S.R. 477B				
KC	S.R. 413				
MC	S.R. 415				

CODE FOR SMOKE, STAR AND INCENDIARY COMPOSITIONS—contd.

(Not applicable to Air Service stores)

Code	Composition	Code	Composition	Code	Composition
GH	Rocket composition	QH	S.R. 306 and S.R. 460	NJ	S.R. 905 and S.R. 907
HH	Smoke composition	TH	S.R. 288 and rocket composition	OJ	Calcium magnesium phosphide
JH	Aluminium, Magnesium phosphide, Fast calcium phosphide, Sodium Nitrate and potassium acid sulphate.	UH	S.R. 427 and rocket composition	PJ	S.R. 904M
KH	Aluminium, Magnesium phosphide, Calcium phosphide, Sodium nitrate and potassium acid sulphate	WH	F. 3	QJ	S.R. 213 and S.R. 236
		YH	Delay composition filling composition, and match composition PN 196	RJ	S.R. 806
		ZH	P.N. 398	SJ	S.R. 801A and S.R. 804
		AJ	P.N. 405	TJ	S.R. 397
		BJ	P.N. 411	UJ	P.N. 118 and P.N. 120
LH	Portfire composition	CJ	P.N. 421	WJ	S.R. 264A(M) and S.R. 264B
MH	Potassium nitrate	DJ	P.N. 422	YJ	P.N. 327
NH	Star composition, Delay composition and flare composition	EJ	P.N. 429	ZJ	S.R. 456
		FJ	P.N. 432	BK	S.R. 264A and S.R. 269
OH	Sodium phosphide	GJ	P.N. 436	CK	S.R. 264B and S.R. 264D
		HJ	P.N. 437	DK	S.R. 300
PH	S.R. 580 and potassium nitrate	JJ	S.R. 264B	EK	S.R. 479A and S.R. 477A
		KJ	S.R. 264D	FK	S.R. 477A and S.R. 232
		LJ	P.N. 453		
		MJ	P.N. 454		



CODE FOR TRACER MARKING

MARKING USED TO DENOTE PROJECTILE IS DESIGNED FOR TRACER.	MARKING USED TO DENOTE PROJECTILE IS FITTED WITH TRACER.	
		+ CODE FOR NUMBER OF TRACER ⊕ SUFFIX CODE FOR MARK OF TRACER

Code *	Suffix code *	Time of trace		Tracer Number
		LS	N	
A	A	5-10	—	No. 1, Mark 4
A	B	5-10	—	No. 1, Mark 5
A	C	—	7	No. 1, Mark 6
A	D	8	7	No. 1, Mark 6A
B	A	—	7	No. 2, Mark 5
B	B	8	7	No. 2, Mark 5A
B	C	6-10	—	No. 2, Mark 6R
B	D	6-10	—	No. 2, Mark 6S
B	E	6-10	—	No. 2, Mark 7
B	F	—	7	No. 2, Mark 3C
C	A	4	—	No. 4, Mark 1
D	A	8	—	No. 6, Mark 2
E	A	—	12	No. 8, Mark 1
E	B	—	12	No. 8, Mark 2
F	A	12	12	No. 9, Mark 1
F	B	10-12	12	No. 9, Mark 2
G	A	6	6	No. 13, Mark 1
G	B	6	6	No. 13, Mark 1A
G	C	—	6	No. 13, Mark 1B
H	A	2	—	No. 15, Mark 1
H	B	—	—	No. 15, Mark 1B
J	A	—	—	No. 16, Mark 2
K	A	—	—	No. 17, Mark 1
K	B	—	—	No. 17, Mark 2
L	A	—	—	No. 18, Mark 1
M	A	—	—	No. 19, Mark 1
M	B	—	—	No. 19, Mark 1S

The first two columns, marked "*", are applicable to Naval Service only. These symbols are omitted on all Land Service fixed ammunition.
 In Land Service a T in the eyebrow shows that the projectile is fitted with a tracer.



CODE FOR TRACER FUZE MARKING

MARKING USED TO DENOTE PROJECTILE IS DESIGNED FOR TRACER.	MARKING USED TO DENOTE PROJECTILE IS FITTED WITH TRACER.	
		+ CODE FOR NUMBER OF TRACER ⊕ SUFFIX CODE FOR MARK OF TRACER

Code *	Suffix code *	Time of trace		Tracer Number
		LS	N	
A	A	—	2	No. 287, Mark 11

*See page 34.

CODE FOR TRACER IGNITER MARKING

MARKING USED TO DENOTE PROJECTILE IS DESIGNED FOR TRACER IGNITER.	MARKING USED TO DENOTE PROJECTILE IS FITTED WITH TRACER IGNITER.	
		<p style="margin: 0;">+ CODE FOR TRACER</p> <p style="margin: 0;">⊕ SUFFIX CODE FOR MARK OF TRACER</p> <p style="margin: 0;">× TIME TO SELF DESTRUCTION</p>

Code *	Suffix code *	Time to self destruction		Igniter Tracer Number
		L.S.	N.	
A	A	6	—	No. 7, Mark 4
A	B	6	—	No. 7, Mark 4R
B	A	6	—	No. 10, Mark 4
B	B	6	—	No. 10, Mark 4R
B	C	6	—	No. 10, Mark 4B
C	A	7	7	No. 11, Mark 3
C	B	7	7	No. 11, Mark 3R
C	C	—	7	No. 11, Mark 3B
D	A	7	7	No. 12, Mark 2
D	B	7	7	No. 12, Mark 2R
D	C	—	7	No. 12, Mark 2B
E	A	12	12	No. 14, Mark 2
E	B	12	12	No. 14, Mark 2R
E	C	—	12	No. 14, Mark 2B

* See page 34.



CODE FOR IGNITER MARKING

MARKING USED TO DENOTE PROJECTILE IS DESIGNED FOR IGNITER.	MARKING USED TO DENOTE PROJECTILE IS FITTED WITH IGNITER.	
		<p>+</p> CODE <p>⊕</p> SUFFIX CODE <p>×</p> TIME TO SELF DESTRUCTION

Code *	Suffix code *	Time to self destruction		Igniter
		L.S.	N.	
A	A	—	7	No. 1, Mark 1
A	B	—	3	No. 1, Mark 2
A	C	—	7	No. 1, Mark 3
A	D	—	3	No. 1, Mark 4
B	A	3	—	No. 2, Mark 1
C	A	—	17	No. 3, Mark 1
C	B	—	17	No. 3, Mark 2
D	A	—	7	No. 4, Mark 1

* See page 34.





CODE FOR DARK IGNITION TRACER MARKING

MARKING USED TO DENOTE PROJECTILE IS DESIGNED FOR TRACER IGNITER.	MARKING USED TO DENOTE PROJECTILE IS FITTED WITH TRACER IGNITER.	
		+ CODE FOR NUMBER OF TRACER  SUFFIX CODE FOR MARK OF TRACER

Code *	Suffix code *	Time of trace		Tracer Number
		L.S.	N.	
A	A	—	8	No. 1, Mark 7
B	A	—	8	No. 2, Mark 8
D	A	—	5	No. 4, Mark 2
G	A	—	8	No. 13, Mark 2
G	B	—	8	No. 13, Mark 3
J	A	7	—	No. 16, Mark 1
J	B	—	12	No. 16, Mark 3

* See page 34.

CODE FOR DARK IGNITION TRACER IGNITER MARKING

MARKING USED TO DENOTE PROJECTILE IS DESIGNED FOR TRACER IGNITER.	MARKING USED TO DENOTE PROJECTILE IS FITTED WITH TRACER IGNITER.	
 	 	+ CODE FOR TRACER ⊕ SUFFIX CODE FOR MARK OF TRACER × TIME TO SELF DESTRUCTION

Code *	Suffix code *	Time to destruction		Igniter Tracer Number
		L.S.	N.	
A	A	—	3	No. 7, Mark 3
A	B	—	7	No. 7, Mark 4
A	C	—	3	No. 7, Mark 5
A	D	—	7	No. 7, Mark 6
C	A	—	12	No. 14, Mark 4
C	B	—	12	No. 14, Mark 5

* See page 34.

RESTRICTED

W.O.
CODE No.
1803

The information given in this document is not to be
communicated, either directly or indirectly, to the Press
or any person not authorized to receive it.

**INTER - SERVICE
AMMUNITION
&
AMMUNITION PACKAGE
MARKINGS**

**SECTION 3
Cartridges
1950**

This Section having been approved by the Lords Commissioners of the Admiralty, by the Army Council and by the Air Council, is promulgated for information and guidance.

By Command of their Lordships

J. G. Lang

By Command of the Army Council

G. W. Sumner

By Command of the Air Council

J. H. Barwell

CONTENTS

Introduction—	Para.
Methods of marking	1
Colour markings	2
Coloured or dyed fabrics	3
Stencilling	4
Stampings	5
Additional means of identification	6
Mortar cartridges	7
Markings on miscellaneous cartridges	8
Table 1—Propellant identification code	

LIST OF PLATES

Stencilling on—	Plate
Cartridges to indicate charges designed for special purposes	1
Q.F. cartridges (separate loading)	2
Q.F. cartridges (fixed) marked under the batching system	3
Q.F. cartridges (fixed) not marked under the batching system	4
B.L. cartridges	5
Igniters	6
Stampings	7
Mortar cartridges	8

INDEX

	A		Para.	Page
Additional means of identification			6.	10
Augmenting cartridges (mortar)—labels			7.2.	11
B				
B.L. Cartridges—stencilling			4.7.	9
C				
Cartridges, B.L.—stencilling			4.7.	9
Cartridges, Q.F. (separate loading)—stencilling			4.4.	6
Cartridges, Q.F. (fixed) stencilling—				
Marked under the batching system			4.5.	6
Not marked under the batching system			4.6.	8
Cartridges, miscellaneous—				
Markings on			8.	11
Filled cartridge			8.2.	11
Particulars of empty case			8.1.	11
Cartridge bags—other markings			4.8.	9
Cartridges augmenting (mortar)—labels			7.2.	11
Colour markings			2.	5
Land Service			2.2.	5
Naval Service			2.1.	5
Coloured or dyed fabrics			3.	5

	I	Para.	Page
Igniters—stencilling		4.9.	9
L			
Labels—augmenting cartridges (mortar)		7.2.	11
M			
Marking on miscellaneous cartridges		8.	11
Filled cartridge		8.2.	11
Particulars of empty case		8.1.	11
Methods of marking		1.	5
Mortar cartridges		7.	11
Augmenting		7.2.	11
Primary		7.1.	11
O			
Other markings on cartridge bags		4.8.	9
P			
Particulars of empty case—miscellaneous cartridges		8.1.	11
Primary cartridges (mortar)		7.1.	11
Propellant Identification Code		Table I	12
Q			
Q.F. cartridges (general)—stencilling		4.1.	5
Q.F. cartridges (separate loading)—stencilling		4.4.	6
Q.F. cartridges (fixed)—stencilling—			
Marked under the batching system		4.5.	6
Not marked under the batching system		4.6.	8
S			
Stampings		5.	10
Size of		5.1.	10
Stencilling		4.	5
B.L. cartridges		4.7.	9
Igniters		4.9.	9
On cartridges to indicate charges designed for special purposes		4.3.	6
Q.F. cartridges (general)		4.1.	5
Q.F. cartridges (separate loading)		4.4.	6
Q.F. cartridges (fixed)—			
Marked under the batching system		4.5.	6
Not marked under the batching system		4.6.	8
Size of		4.2.	5
On the base		4.2.1.	5
On the side		4.2.2.	6
Propellant letters and special markings		4.2.3.	6

RESTRICTED

1. METHODS OF MARKING

The methods of marking in this Section conform with those laid down in Section 1, General Introduction, which should be read in conjunction with it.

They consist of:—

- Colour Markings.
- Coloured or dyed fabrics.
- Stencilling.
- Stampings.
- Labels.

2. COLOUR MARKINGS

Basic body colours involving the use of paint are not used for identification, as paint on cartridge bag fabrics or on cartridge cases might introduce undesirable effects.

2.1. In *Naval Service*, the following colour markings are used on cartridges as appropriate:—

A white cross on the base of Q.F. cartridge cases indicates a flashless charge.

A red band on the body of B.L. bags indicates the igniter end of the charge. (This is applied to 6-inch cartridges and above).

A black band on the body of B.L. bags indicates the position of the tin foil in the charge. (This is applied to 6-inch cartridges and above).

2.2. In *Land Service*, the following colour markings are used:—

A black band, $1\frac{1}{2}$ inches wide around the base end of a case, denotes a high velocity charge.

A black band, 1 inch wide and 7 inches from one end of a B.L. 5.5-inch gun cartridge denotes a super charge for use with 80-lb. shell only.

3. COLOURED OR DYED FABRICS

Dyed fabrics are used for making up igniter bags and in the case of Land Service they aid identification of the charges for certain Q.F. separate loading cartridges.

4. STENCILLING

Stencilling, or any other method of lettering, is the only method of indicating particulars relating to the filling on filled cartridges.

4.1. *Stencilling on Q.F. cartridges (General)*

Particulars relating to the filling are stencilled in silver nitrate. In exceptional circumstances, where delay entailed by the use of silver nitrate cannot be accepted, special paint may be used. The use of such paint for marking is restricted to the minimum.

Particulars of filling may be stencilled on the base of the cartridge case. On cases where the base does not provide sufficient room for stencilling, the side of the case is utilized for all or part of the stencilling.

4.2. *Size of Stencils*

The size of the stencils used for the various calibres of cartridges is as follows:—

4.2.1. *On the base.*

Up to and including 6-pr.
Above 6-pr.

$\frac{3}{8}$ -inch
 $\frac{3}{4}$ -inch

4.2.2. On the Side

Up to and including 6-pr.	$\frac{1}{4}$ -inch
Above 6-pr.	$\frac{3}{8}$ -inch

4.2.3. Propellant letters and special markings 1-inch.

4.3. Stencilling on Cartridges to indicate charges designed for special purposes (Plate 1)

SUPER	indicating	super charge
SV	”	super velocity charge
HV	”	high velocity charge
RED	”	reduced charge
PRAC RED	”	practice reduced charge
CLEARING	”	clearing charge
BLANK	”	blank charge
BOM	”	bombardment charge (NS)
AA	”	suitability for anti-aircraft practice firing (NS)
BF TGT	”	charge for back firing target shell (NS)
FLG TGT	”	charge for falling target shell (NS)

4.4. Stencilling on Q.F. Cartridges (Separate loading) (Plate 2)

4.4.1. Cases are stencilled as follows :—

Mark of the filled cartridge.

Propellant identification letters, shape letters and size figures (Land Service) (see Table 1).

SML or FHL denoting smokeless or flashless cartridges respectively (Land Service).

Propellant lot number or numbers. This may be prefixed by the letter “ C ” for a composite lot in Naval Service or suffixed by the letter “ R ” for a re-worked lot in both Naval and Land Service.

Nominal charge weight. (Naval Service only).

Recognized mark or initials of the filler.

Date of filling (month and year).

“ R.U. ” indicating cartridges which are, or have been, stowed in ready use lockers (Naval Service).

4.4.2. Bags containing sectioned charges are marked as follows :—

Calibre.

Mark of filled cartridge.

Propellant identification letters, shape letter and size figures (see Table 1).

Lot number of propellant.

SML or FHL denoting smokeless or flashless cartridges respectively.

Nominal charge weight.

Date of filling (month and year).

Recognized mark or initials of the filler.

Recognized mark or initials (not visible after filling) of the Contractor making the empty bag.

4.5. Stencilling on Q.F. cartridges (fixed) marked under the Batching System (Plate 3)

In Land Service, to facilitate issue to the user of homogeneous groups of ammunition;

4.5. (cont.)

to simplify the tracing and elimination of faulty components ; to reduce stencilling to a minimum and enable records to be kept of all components ; fixed cartridges are assembled and marked in groups known as " Batches " or " Sub-batches ".

4.5.1. Each batch is given a prefix letter, known as the batch letter, followed by a serial number.

The batch letter is particular to, and gives indication of, the nature of projectile and charge as follows :—

	BATCH LETTER
Full charge with HE shell	B
» » » piercing shot	E
» » » (white) smoke shell	C
» » » (coloured) smoke shell	D
» » » radar echo shell	W
» » » filled practice projectile	S
» » » weighted practice projectile	T
Reduced charge with HE shell	M
» » » filled practice projectile	U
» » » shot practice flat-head	X

4.5.2. A batch contains only one lot of propellant. It is divided into sub-batches by the next most important component when the number constituting a lot of this component is insufficient to match the number of charges obtainable from the propellant lot. For the method of batching mortar ammunition *see* para. 7.2.

In the case of fuzed ammunition, the sub-batch is governed by the fuze and contains only one fuze lot.

In the case of piercing shot, the sub-batch is governed by the shot and contains only one shot series or lot.

Sub-batches are distinguished by a suffix letter (A B C etc. except I and O) to the batch number, *e.g.* B123C.

B is the batch letter indicating a full charge with H.E. shell.

123 is the batch number, *i.e.* the 123rd batch of B type rounds produced for the equipment.

C is the sub-batch letter indicating that this sub-batch contains a different lot of fuzes (or other sub-batch component) from those in sub-batches A or B.

All other components, *e.g.* gaines, tracers, primers, cartridge cases, etc. in the sub-batch are restricted as far as possible to one lot of each component.

4.5.3. A batch label in the package gives details of the batch and its components.

As each sub-batch is completed at the filling station, a Batch Record Sheet is prepared in duplicate, recording the particulars and quantities of the filled components of the complete round comprising the batch or sub-batch. The original form accompanies the ammunition to the depots and the copy is sent to, and retained by C.I.A., Woolwich. Particulars of any alteration to a component made after issue to the Service are recorded by the depot responsible for the change and particulars of the change notified to C.I.A. and C.I.L.S.A.

4.5.4. *Stencilling on Batched cartridges (Plate 3)*

The following details are stencilled on the side of the cartridge case :—

Mark of the filled cartridge, *i.e.* complete round.

Batch letter and number and sub-batch letter where applicable.

Propellant identification letters, shape letter and size figures (*see* Table 1).

The letters SML or FHL indicating smokeless or flashless cartridges respectively.

4.5.4. (cont.)

For ease of identification, the following details are stencilled on the base of the cartridge case as appropriate :—

HE	indicating	high explosive shell
AP	”	armour piercing shot
APC	”	armour piercing capped shot
APCBC	”	armour piercing capped, ballistic cap shot
APDS	”	armour piercing discarding sabot projectile
SMK	”	smoke, bursting shell
SMK BE	”	smoke, base ejection shell
SMK YEL*	”	coloured smoke, base ejection shell
SMK BX	”	smoke box in shell
PRAC PROJ	”	practice projectile
RE	”	radar echo. The type is indicated by an oblique stroke and suffix letter
FL	”	flash pellet in shell

* or RED, BLU or GRN as applicable.

4.5.5. The presence of a tracer is indicated by the tracer symbol over the letter “ T ”.

4.5.6. In *Naval Service*, a modified form of the batching system is used for 40-mm. ammunition only. The batch letter carries the same significance as in Land Service and is followed by a number which is changed whenever any of the lot numbers of the components of the round alter. Sub-batch letters are not used.

4.6. *Stencilling on Q.E. cartridges (fixed) not marked under the Batching system* (Plate 4)

In *Naval Service*, where (except for 40-mm.) the batch system of marking is not used, cartridge cases are stencilled (as applicable) with details of the nature of the shell as follows :—

RE	indicating	radar echo shell. The type is indicated by an oblique stroke and suffix letter
FLG TGT	”	falling target shell
HE	”	high effect (or high explosive) shell
HE(U)	”	high effect (or high explosive) shell with universal cavity
PRAC	”	practice (inert shell or projectile)
PRAC PROJ	”	practice projectile (AA)
PRAC RED	”	practice with reduced charge
PROOF	”	proof projectile
SAP	”	semi-armour piercing shell
SMK	”	smoke shell
SMK BE	”	smoke, base ejection shell
STAR	”	star shell

A letter “T” is added, as applicable, to the above-mentioned symbols when the shell or projectile is fitted with a tracer.

The following additional stencillings relating to the charge and fuze are also used :—

Mark of filled cartridge, *i.e.* complete round.

Distinguishing letter of propellant manufacturer.

4.6. (cont.)

Lot number of propellant and sub-lot if applicable.
Particulars of fuze when shell is fitted with base fuze.
Recognized mark or initials of the filler.
Date of filling (month and year).
Batch letter and number (40-mm. only).

4.7. *B.L. cartridges (Plate 5)*

The charges of B.L. cartridges are contained in undyed fabric bags on which stencilling and printing are the usual means of identification. Fabrics which have been treated with D.A.N. (dinitro-alpha-naphthol) may assume a yellow colour.

The following are the normal markings which are stencilled in printer's black ink. Red ink may be used to indicate special markings :—

Calibre and (if applicable) the Mark of gun with which the cartridge is to be used.

Mark of the filled cartridge and details of igniter where applicable.

Propellant identification letters, shape letter and size figures (*see* Table 1).

Lot number of propellant. This may be prefixed by the letter " C " for a composite lot in Naval Service or suffixed by the letter " R " for a re-worked lot in both Naval and Land Service.

SML or FHL denoting smokeless or flashless cartridges respectively.

Nominal charge weight.

Date of filling (month and year).

Recognized mark or initials of the filler.

Recognized mark or initials of the Contractor making the empty bag.

A fraction (indicating the fraction of the full charge), *i.e.* $\frac{1}{2}$.

Number of charge, *e.g.* " Charge ONE ".

Where a certain charge consists of a lower charge plus an increment, the "CHARGE" is printed as in the preceding sub-para. The number of the charge, *e.g.* " TWO " is printed on the increment in such a position that when the two are laced together, the word " CHARGE " is in alignment with the charge number.

4.8. *Other markings on cartridge bags*

The word " SUPER " indicating super charge.

The word " REAR " (for 6-inch and above) in Naval Service only.

The number of the lower charge and the calibre are also printed across the bottom of the bag, opposite to the igniter end.

The words " NOT TO BE FIRED SEPARATELY " are printed on the bottom of the charge increment when these can only be fired in conjunction with the lower charge.

The type letter or letters of the bag are printed as close as possible to the mouth of the bag, so that they are hidden by the seam when the bag is closed after filling.

4.9. *Igniters (Plate 6)*

The outer worsted cloth disc of all igniters is dyed red, on which the following details are stencilled or printed in printer's black ink :—

Type letter or number and/or weight in ounces of gunpowder.

Contractor's recognized mark or initials.

Calibre (Naval Service).

NOTE—When the type letter is not used, *e.g.* in the case of igniters made integral with the cartridge bag, it is replaced by the details of the calibre of the weapon and the weight of the charge.

5.

STAMPINGS (Plate 7)

Stampings are used for recording particulars of the empty case on the base of metal cases of Q.F. cartridges, on cartridge clips and on metal components of cartridges.

They are also used on the bases of cartridge cases to denote the number of times they have been filled, fired or re-formed.

Particulars of the empty case normally consist of the following for Naval and Land Service:—

Calibre and Mark of gun or calibre and number of case for 2-pr. HV. The Mark of gun is only included when the cartridge is peculiar to a particular Mark of gun.

Mark of empty case.

Lot number of empty case.

The letter " S " is added to the Mark of the empty case when the primer hole is re-bushed, (Naval Service).

The word " BLANK " when cases are specifically sentenced or manufactured for firing blank only.

Year of manufacture.

Contractor's recognized mark or initials.

Examiner's work mark (Land Service).

Acceptance mark (Land Service).

The word " CLEARING " when cases are specifically sentenced or manufactured for firing clearing charges only.

The letter " G " when cases are sentenced for Gunnery School use only (Naval Service).

Repaired cases are stamped with the monogram of the repairer within a rectangle.

In *Naval Service*, re-formed cases are stamped with the letter " F ". Subsequent re-formings are indicated by a pop or punch mark after the letter " F " followed by the monogram of the repairer.

In *Land Service*, when a case is filled for the first time with a charge other than blank, the letter " F " or " R " indicating full or reduced charge as applicable is stamped on the base (*see Plate 7*).

Each subsequent refilling is indicated by an additional " F " or " R " with the monogram of the factory in which the case was re-formed stamped above it.

In the event of the filling being removed instead of being fired, the " F " or " R " corresponding to the filling is barred out.

5.1. *Size of stampings*

The sizes of stampings used are as follows :—

2-pr. and up to 40-mm.

$\frac{1}{10}$ -inch

3-pr. and up to 6-pr.

$\frac{3}{16}$ -inch

Above 6-pr.

$\frac{1}{4}$ -inch

6.

ADDITIONAL MEANS OF IDENTIFICATION

In *Naval Service*, the following additional means of identification are adopted :—

Milled rim of the cartridge case indicates star shell.

The cartridge case rim milled for half its circumference indicates A.A. sub-calibre ammunition.

In depth charge thrower cartridges and squid projector cartridges, a knurled rim to the cartridge case indicates drill or practice cartridges respectively.

7.

MORTAR CARTRIDGES

Mortar cartridges are identified by stamping, stencilling or printing.

7.1. *Primary cartridges (Plate 8)*

These are marked on the base by stamping and on the side by printing :—

Stamping on the base

Contractor's recognized mark or initials.

Bore of the cartridge.

Printing on the side of the case

Calibre and nature of mortar.

Mark of cartridge.

Propellant identification letters, shape letter and size figures (*see* Table 1).

SML when means of smokeless ignition are provided.

Nominal charge weight.

Recognized mark or initials of the filler.

Printing on the closing disc

Lot number.

Date of filling (month and year).

7.2. *Augmenting cartridges (Plate 8)*

These are usually contained in celluloid cases on which it is not possible to stencil or stamp, therefore labels are used and inserted in the transparent case. They are of white paper, $1\frac{1}{2}$ -inches by $\frac{3}{4}$ -inch with the following particulars printed in black:—

Mark of filled cartridge.

Propellant identification letters, shape letter and size figures (*see* Table 1).

Identification letter and number of the label.

Lot number of propellant.

Nominal charge weight.

Date of filling (month and year).

Recognized mark or initials of the filler.

NOTE—When cartridges are issued with fuzed bombs as complete rounds of mortar ammunition, the rounds are issued in batches as described in paras. 4.5, except that the batches are based on the fuze lot and not the propellant lot. Sub-batches are based on the primary cartridge lot. Batch letters and numbers do not appear on the bomb, but are stencilled on the carriers and ammunition packages.

8. MARKINGS ON MISCELLANEOUS CARTRIDGES (Plate 8)

These follow the foregoing principles, in that the markings relating to the empty store are stamped on the base of the cartridge and those relating to the filled store are stencilled on the side, *e.g.* PIAT cartridge. They are as follows :—

8.1. *Particulars of the empty case*

Contractor's recognized mark or initials.

Year of manufacture.

8.2. *Markings on the filled cartridge*

Mark of cartridge.

Lot number of propellant.

TABLE 1

PROPELLANT IDENTIFICATION CODE

Used in the Marking of Gun and Mortar Cartridges

Designation of Propellant	Identification Letters, etc.
<i>(Nitrocellulose Powders)</i>	
Nitrocellulose Rifle Powder Mk.8Z	NCRP(8Z)
Neonite No. 9	NRN9
Neonite No. 12	NRN12
NCT Powder (U.S. NC (Pyro) i.e. 1914-18 production)	NCT
NH Powder (U.S. Hercules NH)	NH
NH Powder (U.S. Dupont NH—later M.6)	NH
FNH Powder (U.S. Dupont FNH—later M.1)	FNH
FNH Powder (U.S. Hercules FNH—later M.4)	FNH
FNHP Powder (U.S. Dupont production for U.K.)	FNHP
FNHP Powder (U.S. Hercules production for U.K.)	FNHP
<i>(Nitrocellulose—Nitroglycerine Compositions)</i>	
Ballistite B	BAL.B
Cordite A	A
Cordite AN	AN
Cordite ASN	ASN
Cordite HSC	HSC
Cordite HSCK	HSCK
Cordite MC	MC
Cordite MD	MD
Cordite MDC	MDC
Cordite RDB	RDB
Cordite SC	SC
Cordite W	W
Cordite WM	WM
M4X (U.S. Dupont)	M4X
81 mm Mortar Powder (U.S. Hercules)	HERC81mm
FNHDB (U.S. Hercules FNH—later M.2)	FNHDB
FNHDB (U.S. Hercules FNH—later M.5)	FNHDB
<i>(Nitrocellulose—Nitroglycerine—Picrite Compositions)</i>	
Cordite NF	NF
Cordite N	N
Cordite NQF	NQF
Cordite NQ	NQ
Cordite NP	NP
Cordite NQFP	NQFP
Cordite N2P	N2P
Cordite MNF	MNF
Cordite MNQF	MNQF
Cordite MNF2P	MNF2P

NOTE 1

American Propellants

The British nomenclature and identification letters for U.S. gun propellants are not the same as those now used by the Americans. In amplification of the corresponding U.S. designations given in Table 1 the following is a brief summary of the position :—

- NCT** These letters adopted by us in the 1914-18 war to indicate " Nitrocellulose Tubular ", have not been used in the U.S. where the propellant was designated " Powder Propellant Nitro-cellulose (Pyro) " and is now obsolete.
- NH** These letters were in use in the U.S. to mean " Non-hygroscopic " in the designation of both Hercules and Dupont smokeless Cannon Powders when we began to import these propellants in 1940. We used the letters in the designation " NH Powder " which we adopted for both. Later only the Dupont powder was produced and in time became known in the U.S. as " Powder Propellant M.6 ". We have continued to use the designation " NH Powder ".
- FNH** These letters were in use in the U.S. to mean " Flashless, non-hygroscopic " in the designation of both Hercules and Dupont flashless Cannon Powders when we began to import these propellants in 1940. We used the letters in the designation " FNH Powder " which we adopted for both. Later, under American nomenclature, the Hercules powder became " Powder Propellant M.4 " and the Dupont, " Powder Propellant M.1 " and the letters FNH were used only as a marking to indicate a flashless performance in a given gun irrespective of the composition. In time only the M.1 was produced and this we have continued to call " FNH Powder ".
- FNHP** These letters have not been used in the U.S. nomenclature but were adopted in British nomenclature for Hercules and Dupont flashless Cannon Powders specially produced to meet a British requirement in 1940. Later only the Dupont powder was produced.
- FNHDB** These letters have not been used in the U.S. nomenclature but were introduced in the British designation of the two Hercules double base flashless Cannon Powders imported during the 1939-45 war. Under American nomenclature these propellants were later designated " Powders Propellant M.2. " and " M.5. " Neither is used in British ammunition and the letters have remained unchanged.

NOTE 2

Propellant Shape Letters and Size Figures

With certain exceptions, the designation of a propellant includes also the shape and the size dimensions in which the propellant is produced. The exceptions are the propellants which are normally in the finer granular forms and comprise :—

Nitrocellulose Rifle Powder Mk. 8Z
Neonites No. 9 and No. 12
Ballistite
M4X
81-mm Mortar Powder.

The shape (*i.e.* physical form) in which the propellant has been produced is normally indicated by the use of a single code letter as a suffix to the identification code given above. The shape code letter is always preceded by an oblique stroke to separate it from the propellant identification letters. The shape letters used are :—

M	Multi-tubular (Multiple perforations) granules
R	Ribbon (strip)
S	Slotted tubular cord
T	Tubular cord
Z	Scroll

No shape letter is used to indicate propellant in cord (stick) form because this is the normal. Likewise, the suffix letter M is not used in connection with U.S. propellants because "Multi-Perforated" is the American normal.

The nominal size dimensions corresponding to the shape in which the propellant has been produced follow the shape letter, where used, and are given by the appropriate numerals and signs as follows :—

Cord	Diameter, <i>e.g.</i> 16 or 182
Multi-tubular	Mean thickness of webs between perforations, <i>e.g.</i> 055
Ribbon	Thickness and width of strip separated by multiplication sign, <i>e.g.</i> 014 × 048
Scroll	Thickness of sheet, <i>e.g.</i> 008
Slotted tubular cord	External and internal diameters of tube separated by minus sign, <i>e.g.</i> 206 — 100
Tubular cord	As for slotted tubular cord

The use of three figure sizing giving dimensions to one-thousandth of an inch or two figure sizing giving dimensions to one-hundredth of an inch is related to the composition and production process of the propellant.

The following are examples of propellant identification code letters combined with shape letters and size figures :—

SC	150
N2P/M	055
NH	055
NQ/R	014 × 048
SC/Z	008
MNF2P/S	198 — 054
NQ/T	114 — 040

Q.F. CARTRIDGES.

STENCILLING TO INDICATE CHARGES DESIGNED FOR SPECIAL PURPOSES.

<p>1</p>  <p>SUPER CHARGE.</p>	<p>2</p>  <p>SUPER VELOCITY CHARGE.</p>	<p>3</p>  <p>HIGH VELOCITY CHARGE. (LAND SERVICE ONLY)</p>	
<p>4</p>  <p>REDUCED CHARGE.</p>	<p>5</p>  <p>PRACTICE REDUCED CHARGE.</p>	<p>6</p>  <p>CLEARING CHARGE. (LAND SERVICE ONLY)</p>	
<p>7</p>  <p>CLEARING CHARGE. (NAVAL)</p>	<p>8</p>  <p>BLANK CHARGE. (LAND SERVICE ONLY)</p>	<p>9</p>  <p>BLANK CHARGE. (NAVAL)</p>	
<p>10</p>  <p>BOMBARDMENT CHARGE. (NAVAL)</p>	<p>11</p>  <p>SUITABLE FOR ANTI-AIRCRAFT PRACTICE FIRE.</p>	<p>12</p>  <p>BACK FIRING TARGET SHELL.</p>	<p>13</p>  <p>FALLING TARGET SHELL.</p>

Q.F. CARTRIDGES (SEPARATE LOADING).

LAND SERVICE.

STENCILLING ON SIDE OF CARTRIDGE CASE.

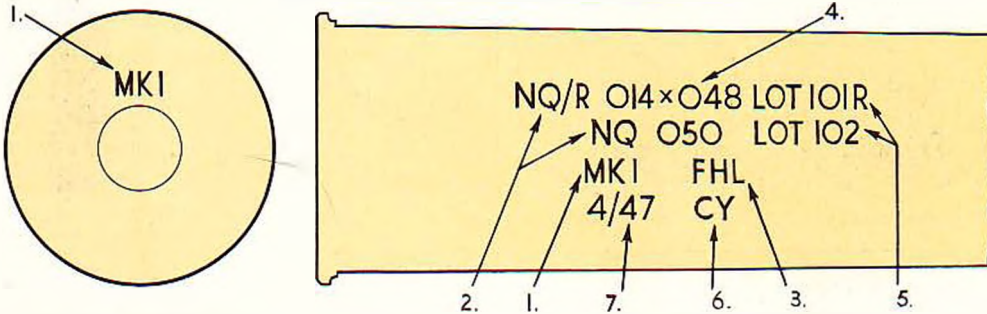

- 1... MARK OF FILLED CARTRIDGE.
- 2... PROPELLANT IDENTIFICATION LETTERS AND SHAPE LETTER.
- 3... SML OR FHL DENOTING SMOKELESS OR FLASHLESS CARTRIDGES RESPECTIVELY.
- 4... PROPELLANT SIZE FIGURES.
- 5... PROPELLANT LOT NUMBERS.
- 6... RECOGNIZED MARK OR INITIALS OF FILLER.
- 7... DATE OF FILLING (MONTH AND YEAR).

2

MARKINGS ON COMPOSITE CHARGE BAGS.

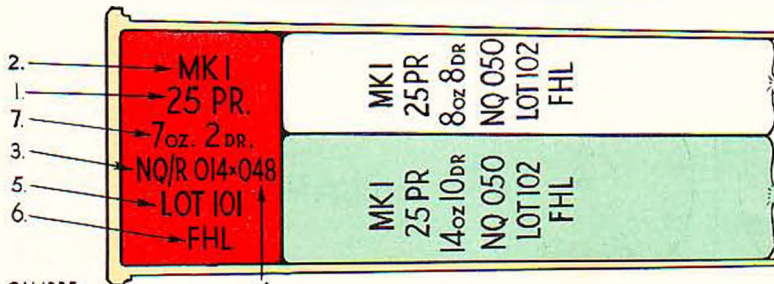

- 1... CALIBRE.
- 2... MARK OF FILLED CARTRIDGE.
- 3... PROPELLANT IDENTIFICATION LETTERS AND SHAPE LETTER.
- 4... PROPELLANT SIZE FIGURES.
- 5... LOT NUMBER OF PROPELLANT.
- 6... SML OR FHL DENOTING SMOKELESS OR FLASHLESS CARTRIDGES RESPECTIVELY.
- 7... NOMINAL CHARGE WEIGHT.

RECOGNIZED MARK OR INITIALS OF FILLER,
AND DATE OF FILLING MONTH AND YEAR.

MARKED ON REVERSE
SIDE OF EACH BAG.

3

NAVAL SERVICE.

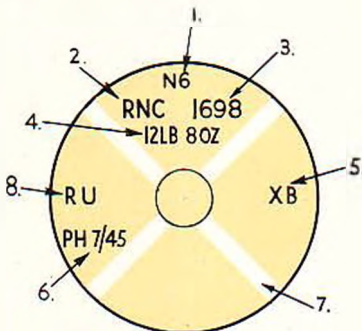

- 1... MARK OF FILLED CARTRIDGE.
- 2... DISTINGUISHING LETTERS OF PROPELLANT MANUFACTURER.
- 3... LOT NUMBER OF PROPELLANT.
- 4... NOMINAL CHARGE WEIGHT.
- 5... SUB LOT PARTICULARS OF CORDITE.
- 6... RECOGNIZED MARK OR INITIALS OF FILLER AND DATE OF FILLING (MONTH AND YEAR).
- 7... WHITE CROSS DENOTING FLASHLESS PROPELLANT.
- 8... RU, INDICATING CARTRIDGES WHICH ARE, OR HAVE BEEN STOWED IN READY USE LOCKERS.

Q.F. CARTRIDGES (FIXED).

STENCILLING UNDER THE BATCHING SYSTEM.
(LAND SERVICE)

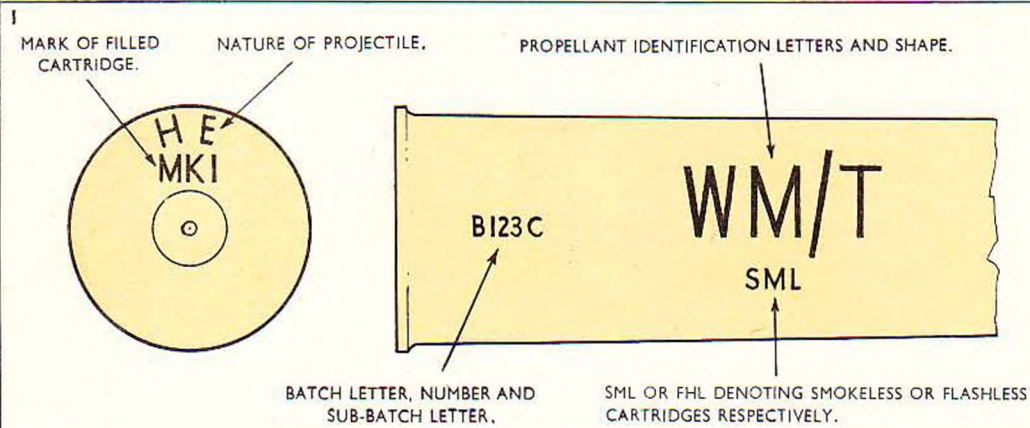

STENCILLING ON BASE OF CASE INDICATING NATURE OF PROJECTILE.

TRACER SYMBOL TO AGREE WITH THAT MARKED ON PROJECTILE.

<p>2</p> <p>H E</p> <p>HIGH EXPLOSIVE.</p>	<p>3</p> <p>A P</p> <p>ARMOUR PIERCING SHOT.</p>	<p>4</p> <p>A P C</p> <p>ARMOUR PIERCING CAPPED SHOT.</p>	<p>5</p> <p>A P C B C</p> <p>ARMOUR PIERCING CAPPED BALLISTIC CAP SHOT.</p>
<p>6</p> <p>A P D S</p> <p>T</p> <p>ARMOUR PIERCING DISCARDING SABOT.</p>	<p>7</p> <p>S M K</p> <p>SMOKE BURSTING SHELL.</p>	<p>8</p> <p>S M K B E</p> <p>SMOKE, BASE EJECTION SHELL.</p>	<p>9</p> <p>S M K Y E L</p> <p>COLOURED SMOKE BASE EJECTION SHELL.</p>
<p>10</p> <p>H E S M K B X</p> <p>SMOKE BOX IN SHELL.</p>	<p>11</p> <p>P R A C P R O J</p> <p>PRACTICE PROJECTILE.</p>	<p>12</p> <p>R E / -</p> <p>RADAR ECHO SHELL.</p>	<p>13</p> <p>F L</p> <p>FLASH PELLET IN SHELL.</p>

Q.F. CARTRIDGES (FIXED).
NOT MARKED UNDER THE BATCHING SYSTEM.
NAVAL SERVICE.

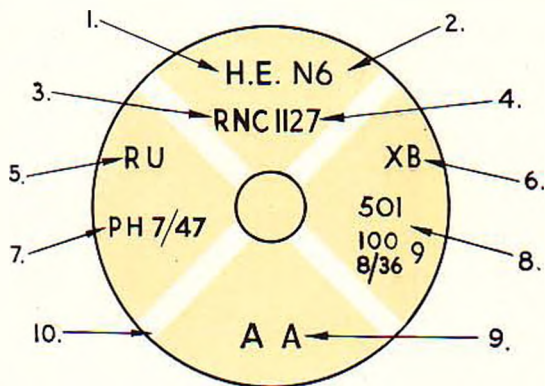

- 1... NATURE OF SHELL (AS APPLICABLE).
- 2... MARK OF FILLED CARTRIDGE, I.E. COMPLETE ROUND.
- 3... DISTINGUISHING LETTER OF PROPELLANT MANUFACTURER.
- 4... LOT NUMBER OF PROPELLANT.
- 5... WHERE APPLICABLE FOR CARTRIDGES STOWED IN, OR EX-READY USE LOCKERS.
- 6... SUB-LOT PARTICULARS OF PROPELLANT.
- 7... RECOGNIZED MARK OR INITIALS OF THE FILLER, AND DATE OF FILLING (MONTH AND YEAR).
- 8... PARTICULARS OF FUZE WHEN SHELL ARE FITTED WITH BASE FUZE.
- 9... NATURE OF CHARGE.
- 10... WHITE CROSS DENOTING FLASHLESS PROPELLANT.

2

FOR CALIBRES UP TO 6PR. THE STENCILLING DETAILS WILL BE FOUND ON THE BODY OF THE CASE AS SHOWN BELOW.

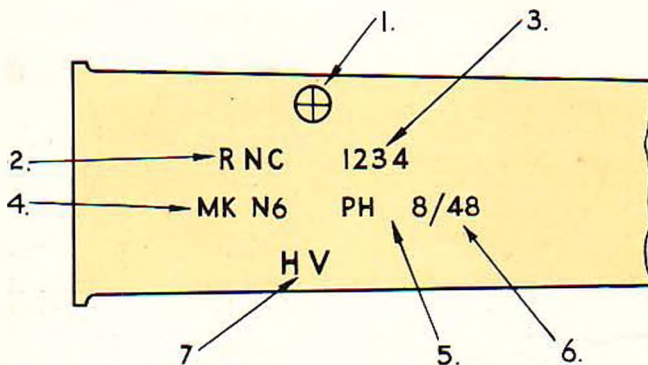

- 1... CROSS IN CIRCLE FOR ROUNDS FILLED CORDITE H5CK/T ONLY.
- 2... DISTINGUISHING LETTERS OF PROPELLANT MANUFACTURER.
- 3... LOT NUMBER OF PROPELLANT.
- 4... MARK OF FILLED CARTRIDGE.
- 5... RECOGNIZED MARK OR INITIALS OF THE FILLER.
- 6... DATE OF FILLING MONTH AND YEAR.
- 7... HV DENOTES HIGH VELOCITY AMMUNITION.

B.L. CARTRIDGES.

LAND SERVICE.

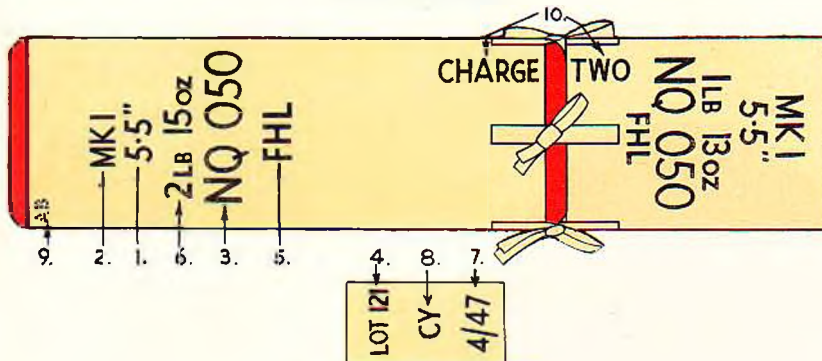

STENCILLED ON REVERSE
SIDE OF EACH BAG

- 1...CALIBRE (AND IF APPLICABLE) MARK OF GUN WITH WHICH THE CARTRIDGE IS TO BE USED.
- 2...MARK OF FILLED CARTRIDGE AND DETAILS OF IGNITER WHERE APPLICABLE.
- 3...PROPELLANT IDENTIFICATION LETTERS AND SIZE.
- 4...LOT NUMBER OF PROPELLANT.

- 5...SML OR FHL DENOTING SMOKELESS OR FLASHLESS CARTRIDGES RESPECTIVELY.
- 6...NOMINAL CHARGE WEIGHT.
- 7...DATE OF FILLING (MONTH AND YEAR).
- 8...RECOGNIZED MARK OR INITIALS OF FILLER.
- 9...RECOGNIZED MARK OR INITIALS OF THE CONTRACTOR MAKING THE EMPTY BAG.
- 10...NUMBER OF CHARGE.

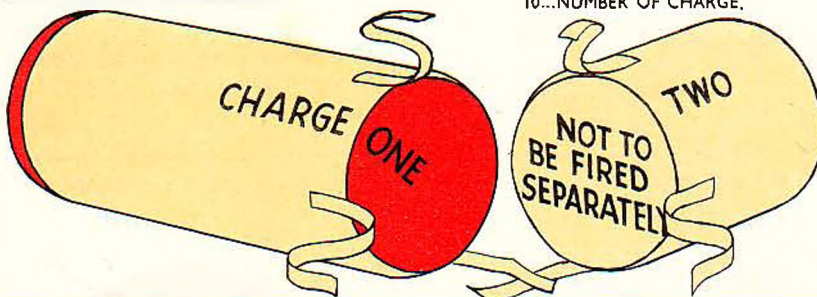

NAVAL SERVICE.

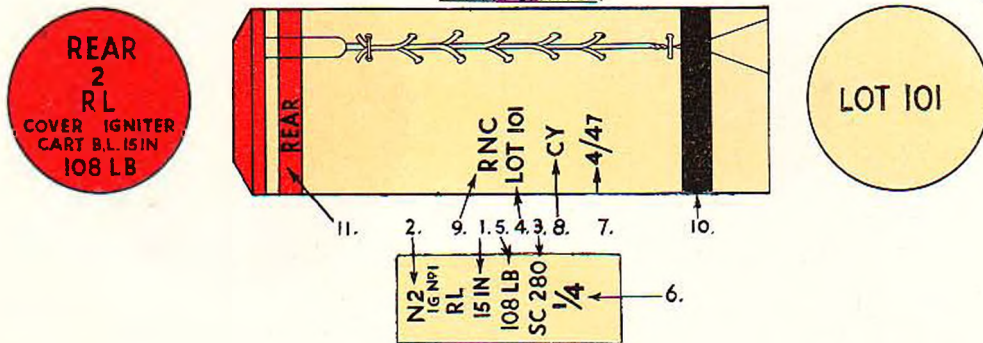

STENCILLED ON REVERSE
SIDE OF BAG.

- 1...CALIBRE (AND IF APPLICABLE) MARK OF GUN WITH WHICH THE CARTRIDGE IS TO BE USED.
- 2...MARK OF FILLED CARTRIDGE AND DETAILS OF IGNITER WHERE APPLICABLE.
- 3...PROPELLANT IDENTIFICATION LETTERS AND SIZE.
- 4...LOT NUMBER OF PROPELLANT.
- 5...NOMINAL CHARGE WEIGHT.

- 6... FRACTION.
- 7...DATE OF FILLING (MONTH AND YEAR).
- 8...RECOGNIZED MARK OR INITIALS OF FILLER.
- 9...INITIALS OF PROPELLANT MANUFACTURER.
- 10...BLACK BAND INDICATING POSITION OF TIN FOIL.
- 11...RED BAND INDICATING IGNITER END.

IGNITERS.
LAND SERVICE.

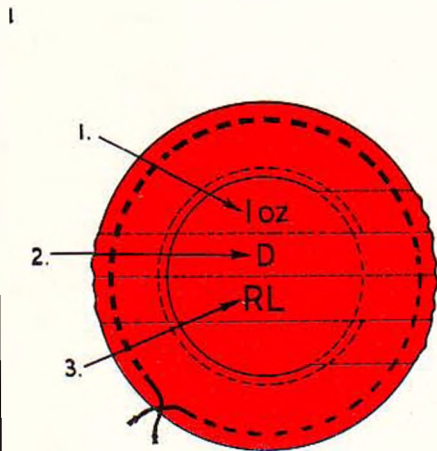

- 1...THE WEIGHT IN OUNCES OF GUNPOWDER.
- 2...TYPE LETTER.
- 3...CONTRACTORS RECOGNIZED MARK OR INITIALS.

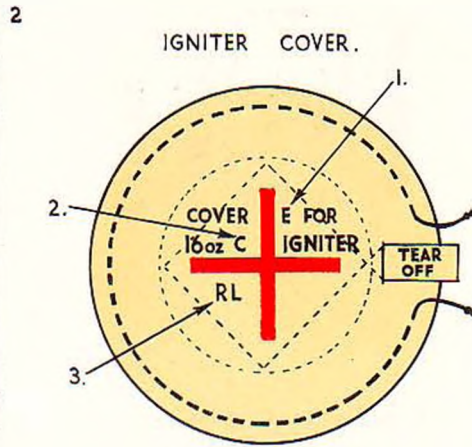

- 1...DISTINGUISHING LETTER OF COVER.
- 2...TYPE LETTER.
- 3...CONTRACTORS RECOGNIZED MARK OR INITIALS.

NAVAL SERVICE (CONCENTRATED).

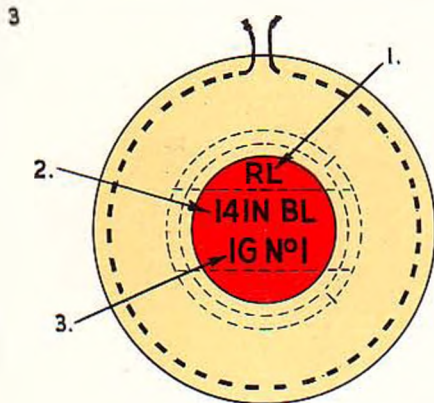

- 1.. CONTRACTORS RECOGNIZED MARK OR INITIALS.
- 2..CALIBRE OF WEAPON.
- 3..TYPE NUMBER.

NAVAL SERVICE (SPREAD).

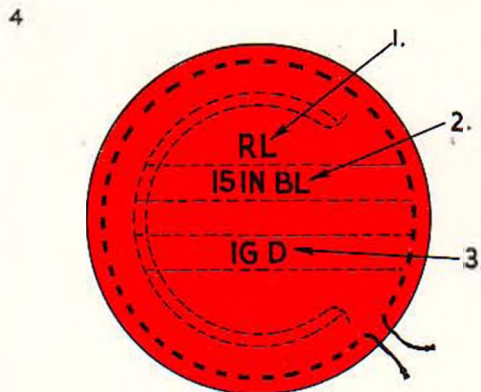

- 1 CONTRACTORS RECOGNIZED MARK OR INITIALS.
- 2..CALIBRE OF WEAPON.
- 3...TYPE LETTER.

CARTRIDGE CASE STAMPINGS.

LAND SERVICE.

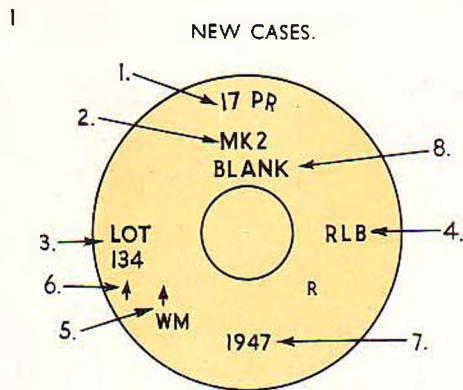

- 1...CALIBRE.
- 2...MARK OF EMPTY CASE.
- 3...LOT NUMBER OF EMPTY CASE.
- 4...CONTRACTORS RECOGNIZED MARK OR INITIALS.
- 5...EXAMINERS WORK MARK.
- 6...ACCEPTANCE MARK.
- 7...YEAR OF MANUFACTURE.

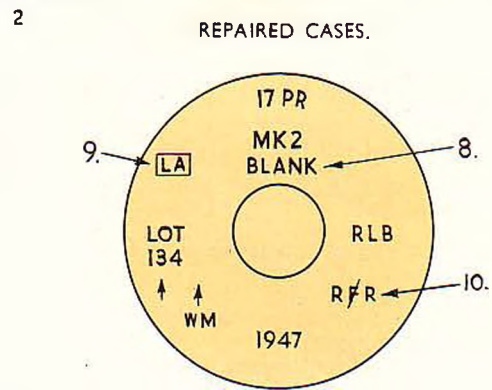

- 8..."BLANK" WHEN CASES ARE SENTENCED OR MANUFACTURED FOR FIRING BLANK ONLY.
- 9...MONOGRAM OF REPAIRER WITHIN A RECTANGLE.
- 10...R=REDUCED CHARGE.
F=FULL CHARGE.
IF BROKEN DOWN WITHOUT FIRING THE LAST INDICATING LETTER BARRED OUT.

NAVAL SERVICE.

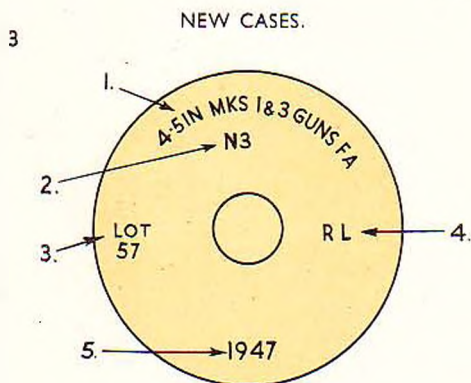

- 1...CALIBRE AND MARK OF GUN.
- 2...MARK OF EMPTY CASE.
- 3...LOT NUMBER OF CASE.
- 4...CONTRACTORS RECOGNIZED MARK OR INITIALS.
- 5...YEAR OF MANUFACTURE.

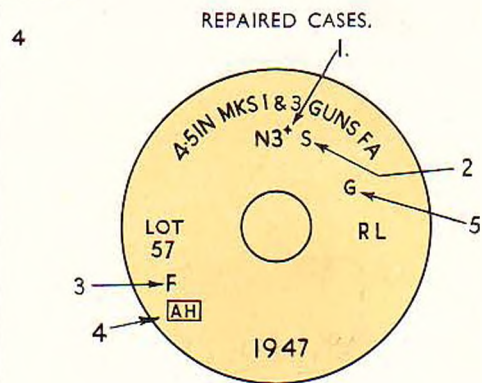

- 1...STAR AFTER MARK DENOTES CONVERSION.
- 2...S AFTER MARK DENOTES PRIMER HOLE RE-BUSHED.
- 3...FIRST REFORMING, SUBSEQUENT REFORMINGS ARE INDICATED BY POP MARK AFTER LETTER F.
- 4...MONOGRAM OF REPAIRER WITHIN A RECTANGLE.
- 5...THE LETTER G WHEN CASES ARE SENTENCED FOR GUNNERY SCHOOL USE ONLY.

MORTAR CARTRIDGES.

1

PRIMARY CARTRIDGES.

1...CONTRACTORS RECOGNIZED MARK OR INITIALS.
2...BORE OF THE CARTRIDGE.
3...CALIBRE AND NATURE OF MORTAR.
4...MARK OF CARTRIDGE.
5...PROPELLANT IDENTIFICATION LETTERS.
6...SML WHEN MEANS OF SMOKELESS IGNITION ARE PROVIDED.
7...NOMINAL CHARGE WEIGHT.
8...RECOGNIZED MARK OR INITIAL OF THE FILLER.
9...LOT NUMBER.
10...DATE OF FILLING (MONTH AND YEAR).

2

LABEL FOR AUGMENTING CARTRIDGES.

1...MARK OF FILLED CARTRIDGE.
2...PROPELLANT IDENTIFICATION LETTERS.
3...IDENTIFICATION LETTER AND NUMBER OF THE LABEL.
4...LOT NUMBER OF PROPELLANT.
5...NOMINAL CHARGE WEIGHT.
6...DATE OF FILLING. (MONTH AND YEAR)
7...RECOGNIZED MARK OR INITIAL OF THE FILLER.

3

P.I.A.T. CARTRIDGE.

STENCILLING.

1...MARK OF CARTRIDGE.
2...LOT NUMBER OF PROPELLANT.

STAMPING

3...CONTRACTORS RECOGNIZED MARK OR INITIALS.
4...YEAR OF MANUFACTURE.

RESTRICTED

The information given in this document is not to be communicated, either directly or indirectly, to the Press or to any person not authorized to receive it.

W.O.
CODE No.
5858

**INTER-SERVICE
AMMUNITION
AND
AMMUNITION PACKAGE
MARKINGS
1948**

SECTION 4

**Fuzes, pistols, shell igniters, gages, tubes
and primers etc. (other than for small arms
ammunition).**

This Section having been approved by the Lords Commissioners of the Admiralty, by the Army Council and by the Air Council, is promulgated for information and guidance.

By Command of their Lordships.

J. G. Lang

By Command of the Army Council.

Eric B. B. Ford.

By Command of the Air Council

J. H. Barnes

CONTENTS

	Para.
Introduction—	
Methods of colour identification and marking	1
Colour markings	2
Stencilling	3
Stampings and embossings	4
Labels and tags	5
Drill fuzes	6

LIST OF PLATES

	Plate
Fuzes—	
Land Service	1
Naval Service	2
Air Service	3

INDEX

	Para.	Page
A		
Additional colour markings	2.4	5
B		
Base of fuze—colouring	2.2	5
Basic colours	2.1	5
drill fuzes	6.1	7
C		
Colour—		
identification and marking—methods of		
markings	1	5
additional	2	5
additional	2.4	5
Coloured rings	2.3	5
Colours—		
basic	2.1	5
drill fuzes	6.1	7
having no identification significance	2.5	5
D		
Drill fuzes	6	7
stampings	6.3	8
stencilling	6.4	8
E		
Embossing and stampings	4	6
Empty stampings	4.1	6
F		
Filled stampings	4.2	6
Fuze base—colouring	2.2	5
Fuzes, drill	6	7
percussion—how marked	6.2	7
stampings	6.3	8
stencilling	6.4	8
I		
Identification—colours having no significance	2.5	5

L

	Para.	Page
Labels and tags	5	7

M

Markings—		
colour	2	5
percussion fuzes	6.2	7
special	4.4	7
Methods of colour identification and marking	I	5

O

Other colour markings	2.4	5
------------------------------	-----	---

P

Percussion fuzes—how marked	6.2	7
Position and size of stampings	4.3	7

R

Rings, coloured	2.3	5
------------------------	-----	---

S

Size and position of stampings	4.3	7
Special markings	4.4	7
Stampings	I.1	5
drill fuzes	6.3	8
empty	4.1	6
filled	4.2	6
position and size	4.3	7
Stampings and embossing	4	6
Stencilling	3	5
drill fuzes	6.4	8
on fuzes not strong enough to be stamped, where used	3.1	5
... ..	3.2	5

T

Tags and labels	5	7
------------------------	---	---

INTRODUCTION

1. METHODS OF COLOUR IDENTIFICATION AND MARKING

The methods of marking in this Section conform with those laid down in Section 1, General Introduction, which should be read in conjunction with this Section.

1.1. *Stampings*

Stampings are used to a far greater degree than any of the other methods of marking. In most instances they are the only identification markings.

2. COLOUR MARKINGS

2.1. *Basic colours*

These are not used on body or cover for identification except that drill fuzes are coloured Black. (See para. 6.)

2.2. The bases of base fuzes are not coloured, since the cover plate of the projectile (or the tracer), by which they are obscured, is marked for identification by the user, in accordance with plate 8 in Section 2.

2.3. *Coloured rings*

2.3.1. The Red filling ring, as found for example on filled projectiles, is not used on stores governed by this Section.

2.3.2. Coloured rings are used when fuzes of the same external appearance are used in the same type of shell in a given equipment, and when the use of one of these fuzes in mistake for the other would result in an accident, a failure or a degradation of operational performance. These markings are intended to be readily discernible by those supervising the loading of the weapon.

2.3.3. *Size and position of rings*

Rings will be around the fuze in such a position as the design of the fuze permits.

The width of the rings will vary according to the size of the fuze. $\frac{3}{8}$ -inch will normally be the largest.

2.3.4. The colour of these rings may be :

Black
Light Green
Deep Orange.

2.4. *Other colour markings*

2.4.1. Red paint will be used to fill in the stamped fuze number and Mark.

2.5. *Colours having no identification significance*

Certain stores have a natural colour which has no identification significance. This is generally due either to the material used or the application of a corrosion resistant finish. Such natural colours are depicted in Champagne colour in the illustrations.

Examples of natural colours are :—

2.5.1. Anodized aluminium components which have a Green or Blue tint.

2.5.2. Plastic fuze components which may be in various colours.

2.5.3. Bases of stores which are often treated with a Red coloured cement.

3. STENCILLING

3.1. Stencilling is used when the store is not considered strong enough to be stamped, *e.g.*, on barometric fuzes and fuze covers.

3.2. The details of the delay time and height setting of barometric fuzes, also the depth settings of hydrostatic fuzes are invariably stencilled in bold type and in contrasting colours.

4. STAMPINGS AND EMBOSSINGS

The precise identification of all stores covered by this Section is entirely dependent upon this method of marking. These are :—

4.1. *Empty stampings*

- 4.1.1. Store number and Mark (Mark only on tubes).
- 4.1.2. A pistol, as compared with a fuze, is indicated by the letter "P" being prefixed to the number, e.g., P.123. Mk. 1.
- 4.1.3. Manufacturer's monogram.
- 4.1.4. The month and last two figures of the year of manufacture.
- 4.1.5. *Land Service* a two-letter combination (excluding the letter I) is used in alphabetical order to indicate sequence of manufacture (except mechanical fuzes).
The first letter represents a series of 25 lots (usually 50,000 fuzes or primers, etc.) the second letter, the actual lot. Thus :—

AA = The first series of 25 lots	Lot 1
AZ = The first series of 25 lots	Lot 25
BA = The second series of 25 lots	Lot 26
BZ = The second series of 25 lots	Lot 50
ZA = The twenty fifth series of 25 Lots	Lot 601
ZZ = The twenty fifth series of 25 Lots	Lot 625

The second letter is stamped by the Inspection Department representative and indicates that the store has passed empty inspection.

- 4.1.6. A typical example would be "SM 5/47 BF" in which "SM 5/47" is the manufacturer's monogram with month and year of manufacture and "BF" is the two-letter combination indicating the sequence of manufacture.

- 4.1.7. For mechanical fuzes, the sequence of manufacture is indicated by a LOT number, e.g., 1, 2, 3, *et seq.*

The following additional details are also stamped on mechanical fuzes :—

- (a) Number of mechanism.
- (b) If the mechanism is not made by the fuze manufacturer, the mechanism maker's monogram and year of manufacture will precede the mechanism number.

4.1.8. *Naval Service*

The sequence of production from any one manufacturer is indicated by a lot number. These run from 1 to 999 and then start again at 1A.

- 4.1.9. The word LOT is not stamped.
- 4.1.10. The empty lot number also serves as the filled lot number.

4.1.11. *Air Service*

The following particulars are stamped on each fuze :—

- 4.1.12. Number and Mark
- 4.1.13. Manufacturer's monogram
- 4.1.14. Date of manufacture (month and year)

4.2. *Filled stampings*—These consist of :—

- 4.2.1. Filled lot number. These run from 1 to 999 and then start again with a series letter added, i.e., 1A to 999A, 1B to 999B *et seq.* The word LOT is not stamped.
- 4.2.2. Monogram of filling station or initials of filling firm.
- 4.2.3. Date of filling (month and last two figures of the year).
- 4.2.4. A typical example would be "118 CY 9/47" which means filled lot 118, filled at R.O.F. Chorley, in September 1947 (for Naval Service 118 is omitted, see para. 4.1.10).

- 4.2.5. Tubes do not bear filled stampings. Identification is by marking on the package.

4.3. *Position and size of stampings*

4.3.1. The position of stampings on fuzes will be around the body, but certain fuzes made of die-cast metal (161, 162, etc.) have their number, Mark and maker's monogram, etc., embossed around the top of the safety cap, in addition to stampings around the body.

Base fuzes, primers, tubes and tracers are stamped around their base, and some tracers may also be stamped around the body. Gains are stamped around the top.

4.3.2. *Relative position of store number and Mark to other stampings*

Wherever possible, the markings should be in a position where they will not be obscured when assembled to the parent store. This applies particularly to the number and Mark.

4.3.3. *Nose fuzes*—Normally above the filled stampings, the empty stampings being diametrically opposite.

4.3.4. *Other stores*—These are stamped generally on the head or base with a single line of stamping as near the periphery as possible.

The store number will separate the empty and filled stampings, the former being on the left side and the latter on the right side, the intervals between the three groups being as large as space permits. Advantage is taken of key slots, etc. to separate groups.

4.3.5. *Size of stampings*

The store number will be of $\frac{1}{2}$ -inch type, where practicable. On smaller stores, it should be as large as possible.

The empty and filled stampings will be $\frac{1}{8}$ -inch or $\frac{1}{16}$ -inch type.

4.4. *Special markings*

4.4.1. Special stampings on fuzes fitted with time rings.

In order to provide for re-assembly of the same maker's components after separation at filling factories, a single letter identification symbol will be stamped on the body, rings and nose cap. These symbols are of no identification significance to the user.

4.4.2. Primers fitted with percussion caps filled with Q.F. composition will be stamped with a letter "Q" after the filled stamping.

4.4.3. Percussion vent tubes have four V-shaped indents in the rim to identify them from electric vent tubes.

4.4.4. Knurlings may be used for night identification between two fuzes of similar shape but with differing operational use.

4.4.5. Certain safety caps of percussion fuzes may bear instructions to the user. These are embossed on the top of the cap.

5. LABELS AND TAGS.

These are employed to convey warnings or instructions to the user.

6. DRILL FUZES.

6.1. *Basic colour*

All drill fuzes are Black with the exception of the graduated portion and setting index of time fuzes.

6.2. Percussion fuzes will be bored right through from nose to base and horizontally through the body.

Time and time and percussion fuzes will be bored horizontally through the cap and vertically from the base to the horizontal boring, where practicable.

6.3. *Stampings*

6.3.1. Fuze number.

6.3.2. Mark.

6.3.3. The word DRILL will normally be stamped on the fuze body in large type.

6.3.4. The fuze number and Mark, also the word DRILL will be filled in with White paint.

6.4. *Stencilling*

This will be in White where used in lieu of stamping.

FUZES AND PRIMERS (LAND SERVICE)

TYPICAL PERCUSSION FUZES.

EMPTY STAMPINGS.

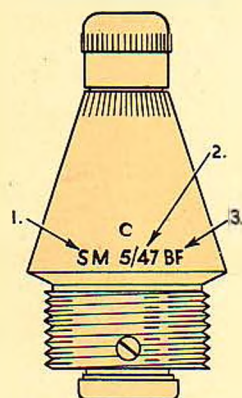

1. MANUFACTURERS MONOGRAM.
2. DATE OF MANUFACTURE (MONTH AND YEAR).
3. TWO LETTER COMBINATION TO INDICATE SERIES LOT NUMBER.

FILLED STAMPINGS.

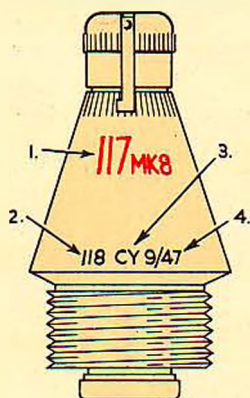

1. STORE NUMBER AND MARK.
2. FILLED LOT NUMBER.
3. MONOGRAM OF FILLING STATION OR INITIALS OF FILLING FIRM.
4. DATE OF FILLING (MONTH AND YEAR).

EMPTY STAMPINGS.

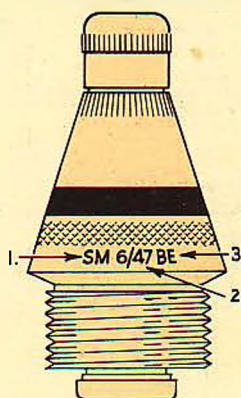

1. MANUFACTURERS MONOGRAM.
2. DATE OF MANUFACTURE (MONTH AND YEAR).
3. TWO LETTER COMBINATION TO INDICATE SERIES LOT NUMBER.

FILLED STAMPINGS.

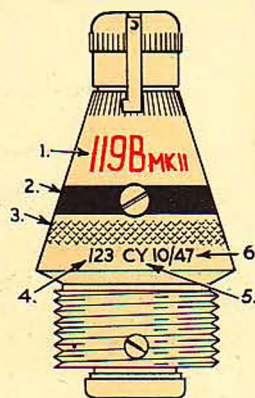

1. STORE NUMBER AND MARK.
2. BLACK RING.
3. KNURLING.
4. FILLED LOT NUMBER.
5. MONOGRAM OF FILLING STATION OR INITIALS OF FILLING FIRM.
6. DATE OF FILLING (MONTH AND YEAR).

TYPICAL TIME FUZE.

EMPTY STAMPINGS.

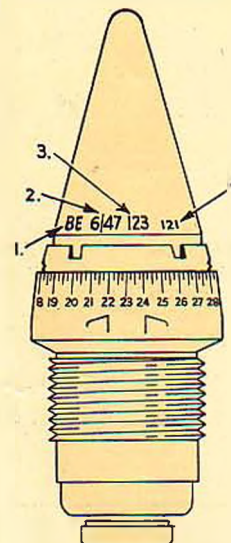

1. MANUFACTURERS MONOGRAM.
2. DATE OF MANUFACTURE (MONTH AND YEAR).
3. LOT NUMBER.
4. NUMBER OF MECHANISM.

FILLED STAMPINGS.

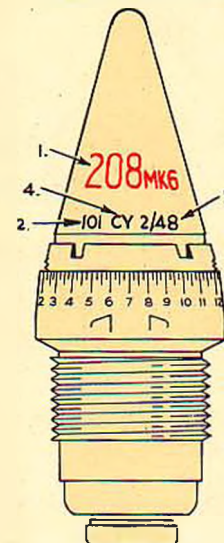

1. STORE NUMBER AND MARK.
2. FILLED LOT NUMBER.
3. DATE OF FILLING (MONTH AND YEAR).
4. MONOGRAM OF FILLING STATION OR INITIALS OF FILLING FIRM.

TYPICAL TIME AND PERCUSSION FUZE (WITH COVER).

EMPTY STAMPINGS.

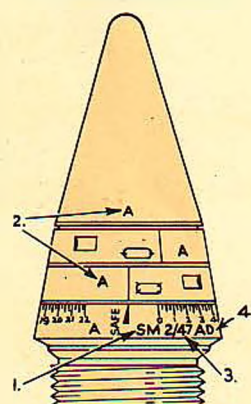

1. MANUFACTURERS MONOGRAM
2. IDENTIFICATION SYMBOL (ON BODY, RINGS AND NOSE CAP)
3. DATE OF MANUFACTURE (MONTH AND YEAR)
4. TWO LETTER COMBINATION TO INDICATE SERIES LOT NUMBER

FILLED STAMPINGS.

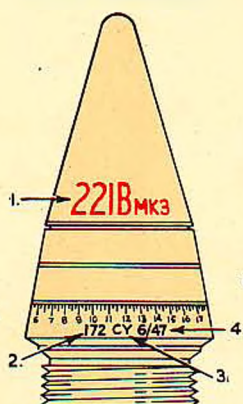

1. STORE NUMBER AND MARK
2. FILLED LOT NUMBER
3. MONOGRAM OF FILLING STATION OR INITIALS OF FILLING FIRM
4. DATE OF FILLING (MONTH AND YEAR)

COVER STENCILLING.

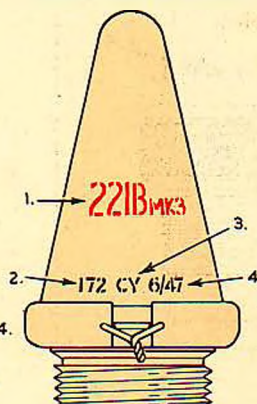

1. STORE NUMBER AND MARK
2. FILLED LOT NUMBER
3. MONOGRAM OF FILLING STATION OR INITIALS OF FILLING FIRM
4. DATE OF FILLING (MONTH AND YEAR)

TYPICAL PRIMER.

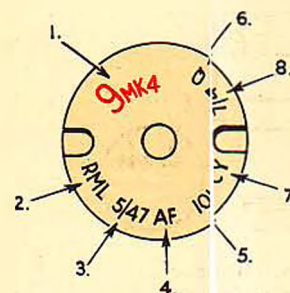

1. STORE NUMBER AND MARK.
2. MANUFACTURERS MONOGRAM.
3. DATE OF MANUFACTURE (MONTH AND YEAR).
4. SERIES LOT NUMBER.
5. FILLED LOT NUMBER.
6. "Q" INDICATING "Q.F." COMPOSITION.
7. MONOGRAM OF FILLING STATION OR INITIALS OF FILLING FIRM.
8. DATE OF FILLING (MONTH AND YEAR).

FUZES (NAVAL SERVICE)

TYPICAL PERCUSSION FUZE.

EMPTY STAMPINGS.

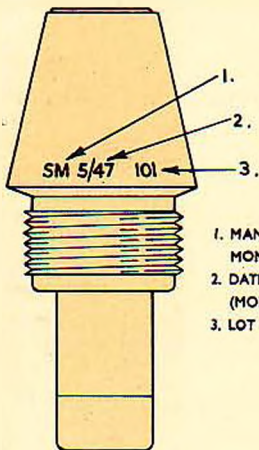

1. MANUFACTURERS MONOGRAM.
2. DATE OF MANUFACTURE (MONTH AND YEAR).
3. LOT NUMBER.

FILLED STAMPINGS.

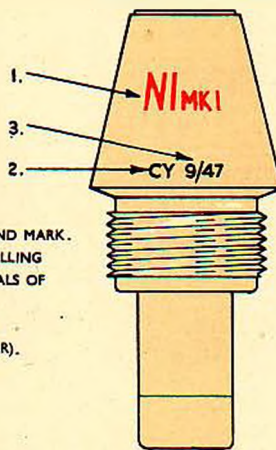

1. STORE NUMBER AND MARK.
2. MONOGRAM OF FILLING STATION OR INITIALS OF FILLING FIRM.
3. DATE OF FILLING (MONTH AND YEAR).

TYPICAL TIME FUZE (WITH COVER).

EMPTY STAMPINGS.

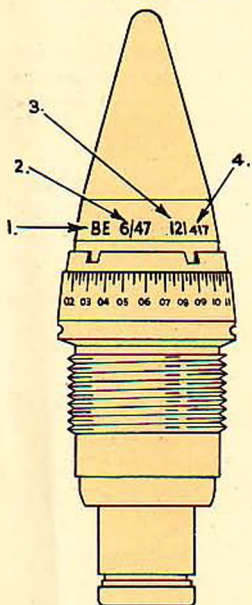

1. MANUFACTURERS MONOGRAM.
2. DATE OF MANUFACTURE (MONTH AND YEAR).
3. LOT NUMBER.
4. NUMBER OF MECHANISM.

FILLED STAMPINGS.

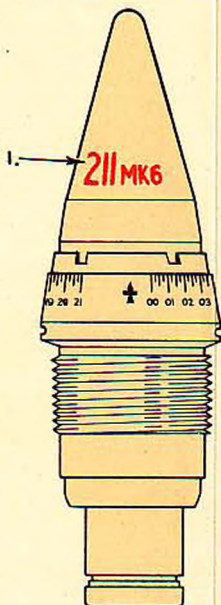

1. STORE NUMBER AND MARK.
2. MONOGRAM OF FILLING STATION OR INITIALS OF FILLING FIRM.
3. DATE OF FILLING (MONTH AND YEAR).



COVER STENCILLING.

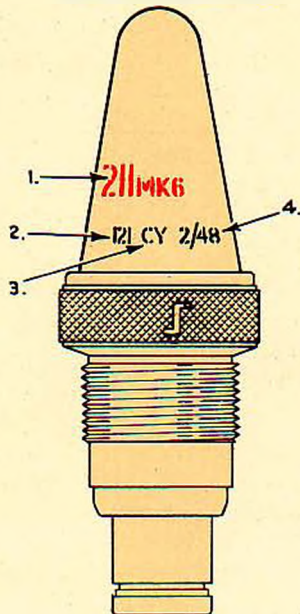

1. STORE NUMBER AND MARK.
2. LOT NUMBER.
3. MONOGRAM OF FILLING STATION OR INITIALS OF FILLING FIRM.
4. DATE OF FILLING (MONTH AND YEAR).

FUZES (AIR SERVICE)

TYPICAL EXAMPLE OF FUZE SUITABLE FOR MARKING BY STAMPING.

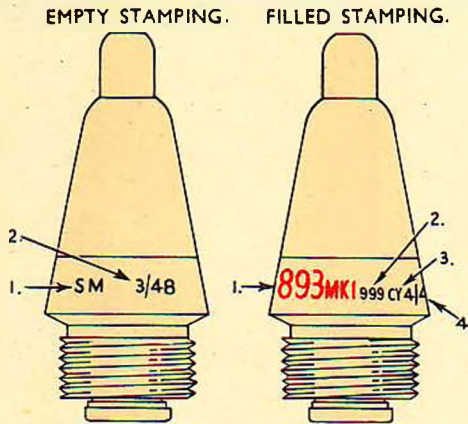

1. MANUFACTURERS MONOGRAM.
2. DATE OF MANUFACTURE (MONTH AND YEAR).

1. STORE NUMBER AND MARK.
2. FILLED LOT NUMBER.
3. MONOGRAM OF FILLING STATION OR INITIALS OF FILLING FIRM.
4. DATE OF FILLING (MONTH AND YEAR).

NOTE.
STORE NUMBER AND MARK IS APPLIED DURING EMPTY MANUFACTURE.

TYPICAL EXAMPLE OF MARKING FUZE OF LIGHT CONSTRUCTION (UNSUITABLE FOR STAMPING LARGE TYPE MARKING).

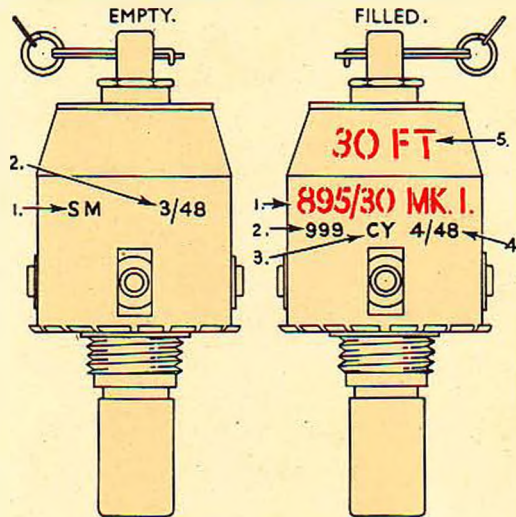

1. MANUFACTURERS MONOGRAM.
2. DATE OF MANUFACTURE (MONTH AND YEAR).

1. STORE NUMBER AND MARK.
2. FILLED LOT NUMBER.
3. MONOGRAM OF FILLING STATION OR INITIALS OF FILLING FIRM.

NOTE.
STORE NUMBER AND MARK IS APPLIED DURING EMPTY MANUFACTURE.

4. DATE OF FILLING (MONTH AND YEAR).
5. DETAILS OF THE DEPTH SETTING.

TYPICAL EXAMPLE OF FUZE MARKING BY STENCILLING (UNSUITABLE FOR STAMPING).

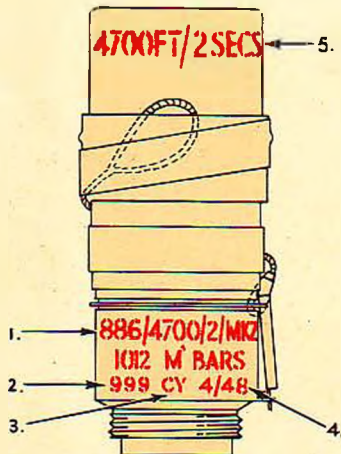

1. STORE NUMBER AND MARK.
2. FILLED LOT NUMBER.
3. MONOGRAM OF FILLING STATION OR INITIALS OF FILLING FIRM.
4. DATE OF FILLING (MONTH AND YEAR).
5. DETAILS OF THE DELAY TIME AND HEIGHT SETTING.

RESTRICTED

W.O.
Code No.
1803

The information given in this document is not to be communicated, either directly or indirectly, to the Press or any person not authorized to receive it.

INTER - SERVICE
AMMUNITION
&
AMMUNITION PACKAGE
MARKINGS

SECTION 5 (Part 1)
Packages (other than S.A.A.)
1951

This Section having been approved by the Lords Commissioners of the Admiralty, by the Army Council and the Air Council, is promulgated for information and guidance.

By Command of their Lordships



By Command of the Army Council



By Command of the Air Council

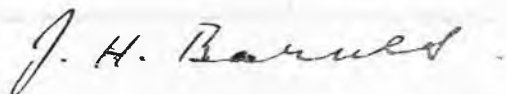

CONTENTS

Introduction—	Para.
Method of marking	1
Colour markings	2
Stencilling	3
Stamping, embossing and branding	4
Labels	5
Metal tags	6

LIST OF PLATES

Stencilling—typical examples—	Plate
Naval Service—	
Steel box containing H.E. ammunition	1
Steel container containing charges	2
Land Service—	
Steel box containing H.E. batched ammunition	3
Steel container for single round of batched ammunition	4
Steel container for single separate loading cartridge	5
Steel box for separate loading Q.F. cartridges	6
Steel box for separate loading shell	7
Steel box for miscellaneous types of ammunition	8
Steel box containing bulk packed fuzes	9
Steel box containing chemical shell	10
Inner containers and cylinders	11
Air Service—	
Ammunition box containing flame stores	12
Cylinder containing aircraft bomb detonators	13
Labels—	
Naval Service—typical contents and sealing	14
Land and Air Service—typical ammunition	15
Government explosive and group	16
Dangerous goods—typical	17

INDEX

A		Para.	Page
Additional stencilling		3.9.	8
dangerous and inflammable goods		3.9.4.	8
for individual services		3.9.7.	9
shell—universal cavity		3.9.6.	9
special ammunition stowage		3.9.3.	8
temperature and climatic limitations		3.9.1.	8
tropicalized		3.9.2.	8
unsuitable for air dropping		3.9.5.	9
Assembled rockets		3.7.4.	8
C			
Colour of stencilling		3.4.	6
Colour of labels		5.1.2.	10

	Para.	Page
Colour markings	2.	6
colour bands	2.4.	6
inner containers	2.3.	6
outer packages	2.1.	6
unpainted	2.2.	6
Components—stencilling of	3.3.	6
Contents labels	5.3.	10
Land Service	5.3.2.	10
Naval Service	5.3.1.	10

D

Dangerous goods labels	5.2.	10
Dangerous and inflammable goods—additional stencilling	3.9.4.	8

E

Empty packages—particulars stamped, embossed or branded on	4.1.	9
--	------	---

G

Government explosive and group number	3.10.	9
colour of stencilling for each Service	3.10.	9
stencilled as alternative to group label	3.10.	9
Government explosive and group labels	5.1.	10
for each Service	5.1.2.	10
Naval Service—how used to indicate shore and afloat group	5.1.3.	10

I

Individual Services—additional stencilling	3.9.7.	9
Inner containers etc.—colour markings	2.3.	6

L

Labels	5.	10
contents	5.3.	10
Land Service	5.3.2.	10
Naval Service	5.3.1.	10
when affixed to inner containers	5.3.3.	11
dangerous goods	5.2.	10
Government explosive and group	5.1.	10
for each Service	5.1.2.	10
Naval Service—how uscd	5.1.3.	10
stencilling as an alternative	5.1.1.	10
packers	5.4.	11
sealing	5.5.	11

M

Metal packages—embossed	4.2.	9
Metal tags	6.	11

N

Nomenclature—stencilling	3.1.	6
----------------------------------	------	---

O

	Para.	Page
Operational markings—stencilling	5.2.	6
Outer packages—colour markings	2.1	6

P

Packer's label	5.4.	11
Particulars on inner containers	3.8.	8
explosive—colour of stencilling	3.8.1.	8
quantity and nomenclature of items packed	3.8.2.	8
Particulars on outer packages	3.7.	7
assembled rockets	3.7.4.	8
Naval Service—to differentiate from other stores	3.7.3.	8
normally stencilled	3.7.1.	7
when applicable	3.7.2.	7
Position of stencilling	3.6.	7

R

Rockets—assembled	3.7.4.	8
---------------------------	--------	---

S

Sealing labels	5.5.	11
Size of stencilling	3.5.	7
Stamping, embossing and branding	4.	9
cellulose containers	4.4.	9
empty packages	4.1.	9
metal packages	4.2.	9
wooden packages	4.3.	9
Stencilling	3.	6
additional	3.9.	8
dangerous and inflammable goods	3.9.4.	8
for individual Services	3.9.7.	9
shell—universal cavity	3.9.6.	9
special ammunition stowage	3.9.3.	8
temperature and climatic limitations	3.9.1.	8
tropicalized	3.9.2.	8
unsuitable for air dropping	3.9.5.	9
colour of	3.4.	6
components	3.3.	6
Government explosive and group number—colour of	3.10.	9
nomenclature	3.1.	6
operational markings	3.2.	6
particulars on outer packages	3.7.	7
assembled rockets	3.7.4.	8
Naval Service—to differentiate from other stores	3.7.3.	8
normal	3.7.1.	7
when applicable	3.7.2.	7
particulars on inner containers	3.8.	8
explosive—colour of stencilling	3.8.1.	8
quantity and nomenclature of items packed	3.8.2.	8
position of	3.6.	7

RESTRICTED

1. METHODS OF MARKING

The methods of marking in this Section conform with those laid down in Section 1, General Introduction, which should be read in conjunction with this Section.

They consist of :—

Colour markings,
Stencilling,
Stamping, Embossing and Branding,
Labels,
Metal Tags.

2. COLOUR MARKINGS

2.1. *Outer Packages*

All outer packages will be painted in a basic body colour of camouflage brown, except those containing chemical ammunition which are painted grey.

2.2. *Unpainted*

Packages and containers made from the following materials are normally unpainted ; they may however carry such special identification markings as necessary.

Cellulosic containers (except when used as an outer package).
Galvanized steel packages.
Packages made of light alloy.

2.3. *Inner Containers etc.*

Inner containers (including tinned plate cylinders and boxes) are normally coloured camouflage brown, except those containing detonators which are painted red, and chemical which are painted grey.

2.4. *Colour bands*

Colour bands have no inter-service significance and are reserved for special purposes and for international use as necessary.

3. STENCILLING

Examples of stencilling on typical packages containing ammunition are given on Plates 1 to 17. Stencilling on packages conveys the following information relating to the contents :—

3.1. *Nomenclature*

The approved nomenclature marking, *i.e.* the main designation of the contents.

3.2. *Operational Markings*

In *Land Service* additional details known as "operational markings" are used. These consist of boldly stencilled abbreviations, which enable the user in an operational area to identify quickly the store he requires. These abbreviations are given in Regulations for Army Ordnance Services.

3.3. *Components*

Detailed information regarding components of the store.

3.4. *Colour*

Normally, yellow paint is used for stencilling on packages. When necessary, a contrasting colour may be used.

3.5. Size

The size of stencilling varies in accordance with the dimensions of the package but should conform to the following :—

For nomenclature and operational markings, and stowage code letters :	Normally 2 inches and $1\frac{1}{4}$ inches.
For component details :	Normally $\frac{1}{2}$ inch and $\frac{1}{4}$ inch according to the size of the package, but no larger than $\frac{3}{4}$ inch.

3.6. Position

The position of stencilling on packages depends on various factors such as :—

- Operational requirements.
- Design of package.
- Method of stacking or stowage.

It is therefore left to the individual services to satisfy their special requirements.

Operational markings, when used, are stencilled on the top and opposite side to that bearing the nomenclature.

Nomenclature markings are usually stencilled on the lid or top and on one side, where the shape of the package permits.

3.7. Particulars on Outer Packages

3.7.1. The following particulars are normally stencilled on the outer packages :—

- Quantity of items packed.
- Quantity of inner packages and type, where applicable.
- Designation and Mark of the complete store or Designation and Mark of main components, as applicable.
- Lot number or Batch number.
- Lot number of propellant, if ammunition is not batched.
- Nature of filling of shell or bombs, as applicable. (See Section 2 for code letters and numbers).
- Method of filling code (Land Service, separate loading shell only).
- Filler's recognized mark or initials.
- Date of filling (month and year).
- Propellant identification code.
- Package serial number.
- FHL or SML indicating Flashless or Smokeless propellant Charge (where applicable).
- Gross weight (lb) Volume (c. ft.).

3.7.2. The following will also be stencilled when applicable :—

- Tracer symbol as marked on the projectile.
- Smoke box symbol. A green disc with " A " or " B " as applicable.
- Decoppering symbol. " DEC " denoting special decoppering rounds.
- " Fraction " when packages do not contain full approved complement of stores.
- HV indicating High Velocity (Naval Service only).

3.7.3. In *Naval Service*, in order to differentiate them from other stores, outer packages containing explosive ammunition are marked on one or more sides with large letters "NA", in red. Packages containing non-explosive ammunition or components are similarly marked in blue, with or without suffixes.

In *Land Service* ammunition packages are marked with an identity symbol consisting of a crown, placed in a conspicuous position on the package.

3.7.4. *Assembled Rockets*

Packages containing assembled rockets will be marked to indicate the position of the head so that when stowed in ships the rocket head can be placed towards the bulkhead. Similarly, when being transported by rail, the heads should be placed longitudinally.

3.8. *Particulars on Inner Containers*

When ammunition or components are packed in closed inner containers which can be removed from the outer package, each inner container will normally be stencilled with the following particulars :—

3.8.1. "EXPLOSIVE", when the stores or components packed fall into one of the Government Explosives Groups. This stencilling will be in red, except for cylinders containing detonators, when it will be in black.

3.8.2. Quantity and nomenclature of items packed, together with lot number, filler and date of filling in case of unbatched ammunition, or Batch Number in case of batched ammunition. This stencilling will be in the colour and size of type best suited to the particular container. In the case of tinned plate containers, tin printing may be used in lieu of stencilling.

For alternative method of marking inner containers see para. 5.3.

3.9. *Additional stencilling*

3.9.1. *Temperature and Climatic Limitations*

In *Land* and *Air Services*, outer packages containing ammunition suitable for use in defined temperature conditions, may be marked as follows :—

UNIV	indicating	Universal*
NOR	„	Normal
LIM	„	Limited
SPL	„	Special

* This marking will eventually supersede the jungle stripes at present in use.

3.9.2. *Tropicalized*

In *Naval Service*, packages which have been specially treated to withstand tropical climates are marked with the letters "TT" in red, inside a red rectangle. Such packages are said to have been "tropicalized", and this marking will supersede the jungle stripes formerly in use on ammunition packages.

3.9.3. *Special Ammunition Stowage*

Packages containing stores classified in Explosives Groups 11 or 13, and charged with toxic chemicals scheduled for "Special Ammunition Stowage" are stencilled with the Sea Transport Code Letters "SAS" (see Comprehensive Classified List of Government Explosives).

3.9.4. *Dangerous and Inflammable Goods*

All outer packages containing ammunition which, because of the nature of its filling or charging, are not classified for storage and transport in an Explosives Group, but are classified by the Ministry of Transport or British Railways as

3.9.4. (cont)

“ Dangerous Goods ” (see note following para. 5.2.), will be stencilled to indicate the following particulars :—

Nature of contents (*e.g.* titanium tetrachloride, bromine).

Type of danger (*e.g.* corrosive, poisonous or inflammable).

Flash point classification of the inflammable goods within the following recognized groups :—

Those with a flash point below 73°F and which are not soluble in water will be stencilled :—

“ HIGHLY INFLAMMABLE F.P. BELOW 73°F ”

Those with a flash point below 73°F and which are soluble in water will be stencilled :—

“ INFLAMMABLE F.P. BELOW 73°F ”

Those with a flash point between 73°F and 150°F will be stencilled :—

“ INFLAMMABLE F.P. BETWEEN 73°F/150°F ”

(see also para. 5.2. relating to labels).

3.9.5. *Unsuitable for Air Dropping*

In *Land Service*, packages containing ammunition which is unsuitable for air-dropping are marked with a Red Triangle.

3.9.6. *Shell—Universal Cavity*

A “ U ” on the package indicates that it contains shell with “ universal cavity ”, *i.e.* a cavity suitable for both normal and V.T. fuzes.

3.9.7. *For Individual Services*

Additional stencilling usually of a self-explanatory nature is sometimes applied by individual services for a particular purpose.

3.10. *Government Explosive and Group Number*

This may be stencilled as an alternative to a group label on each outer package containing explosives (see paras. 5.1. and 5.1.1.). The colour of stencilling will be white on basic colour background.

4. STAMPING, EMBOSsing AND BRANDING

4.1. *Empty packages* usually have the following particulars stamped, embossed or branded, by the manufacturer :—

Package letter and/or number.

Mark.

Contractor's serial number.

Contractor's recognized Mark or initials.

Year of manufacture.

4.2. *Metal packages* are embossed.

4.3. *Wooden packages* are stamped or branded.

4.4. *Cellulosic containers* cannot be stamped, embossed or branded ; it is therefore usual to stencil the particulars of the empty package, or to stamp or emboss the metal ends.

5.

LABELS

5.1. *Government Explosive and Group Labels* (Plate 16)

All packages containing stores classified for storage and transport in an Explosives Group are labelled with a group label carrying a group number which denotes the conditions under which the package is transported and stored (*see* Comprehensive Classified List of Government Explosives).

5.1.1. *Stencilling* is allowed as an alternative (*see* para. 3.10.).

5.1.2. The *label* used with each service is as follows :—

Naval Service—Red on white background, with “ N ” to indicate Naval Service.

Land Service—Red on white background, with “ W ↑ D ” to indicate Land Service.

Air Service—Red on white background, with “ R.A.F.” to indicate Air Service.

5.1.3. In *Naval Service*, where items may be allocated to different groups on board and ashore, a composite group label indicating the shore group in the numerator, and the afloat group in the denominator, is used.

5.2. *Dangerous Goods Labels* (Plate 17)

Special labels to be affixed to outer packages containing ammunition classified as “ Dangerous Goods ” (*see* para. 3.9.4.) in the “ Corrosive ” or “ Poisonous ” classes are shown in Plate 17. The labels of specified dimensions and colours as shown, are each marked near the top with one of the “ traffic letters ” “ A, B, C ” etc. These letters, as applicable, are shown against the “ Corrosive ” and “ Poisonous ” items in the “ Dangerous Goods ” listed by British Railways to indicate the labels which must be used (*see* Note below). Packages which have contained Dangerous Goods in the “ A ” or “ C ” classes must also bear the “ A ” or “ C ” labels when being returned as empties.

NOTE

The Ministers of the Services, although empowered to legislate for the conveyance and storage conditions for explosives, are not so empowered to legislate for dangerous goods. There are, therefore, no Service labels for such goods corresponding to the “ Government Explosives and Group labels ” of the three Services.

Dangerous goods are listed (with instructions regarding their transport by sea) in “ Board of Trade recommendation on the Carriage of Dangerous Goods and Explosives in Ships, 1933 ”. For rail transport, dangerous goods are listed, with conditions of conveyance, in British Railways publication “ Dangerous Goods by Merchandise Trains ” or, if the dangerous goods are of a type used only by Government Service, in their publication “ Railway Executive Committee’s Instructions for Conveyance of Government Goods ”. For dangerous goods not listed, instructions should be obtained from the Explosives Storage and Transport Committee.

5.3. *Contents labels*

Contents labels usually include the details previously mentioned under stencilling in addition to any other information as required.

5.3.1. In *Naval Service* the label, overprinted with large letters “ NA ” (in red, if explosive stores, or in blue, if non-explosive or component stores), is affixed on the outside of a package as convenient, bearing in mind that it must be visible when the package is stacked. Naval packages are often recessed to take this label. It must be protected from damage as far as possible. A duplicate label may be found inside the lid.

5.3.2. In *Land Service*, contents labels or batch labels are affixed inside the lid.

5.3.3. When contents labels are affixed to inner containers containing explosives they are overprinted with the word "EXPLOSIVE", in red (*see* para. 3.8.).

5.4. *Packer's label*

All packages contain a label bearing the initials, etc. of the operative who carried out the packing, together with the station monogram and the date of packing. The label also bears the initials or workmark of the examiner responsible for inspection.

5.5. *Sealing labels*

All packages containing explosives and explosive-filled stores are sealed with muslin sealing labels bearing the monogram of the station carrying out the packing. Unbroken labels indicate that the package has not been opened since the last examination or inspection.

Two labels are normally used and affixed in such a manner that the package cannot be opened without breaking the seal so formed.

Where the package has been packed under inspection, one of the sealing labels bears the monogram of the Inspection Department responsible for the inspection.

Packages may be sealed with soft metal seals stamped with the appropriate monogram.

6.

METAL TAGS

Metal tags for warning or instructional purposes are not normally used on ammunition packages owing to the danger of loss in transit.

RESTRICTED

STEEL BOX CONTAINING H.E. AMMUNITION (NAVAL SERVICE).

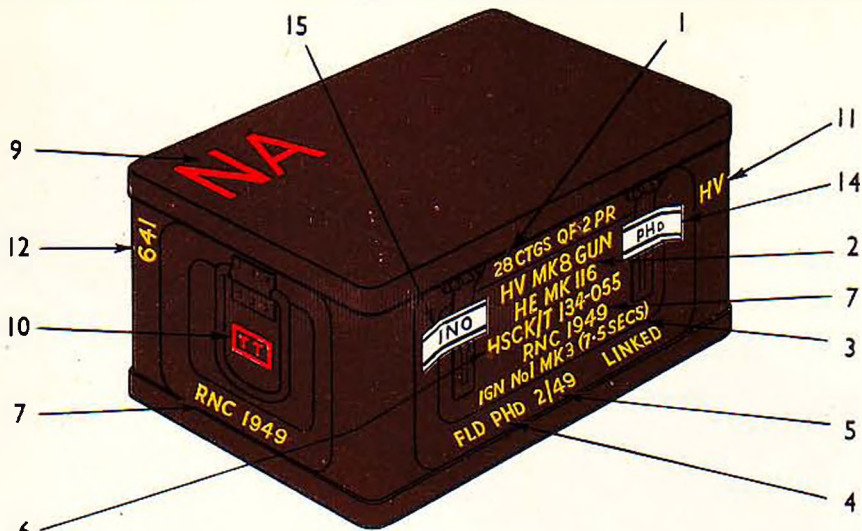

- 1... QUANTITY OF ITEMS PACKED.
- 2... DESIGNATION AND MARK OF THE COMPLETE STORE.
- 3... DESIGNATION OF MAIN COMPONENTS AS APPLICABLE.
- 4... FILLERS RECOGNIZED MARK OR INITIALS.
- 5... DATE OF FILLING (MONTH AND YEAR).
- 6... PROPELLANT IDENTIFICATION CODE.
- 7... LOT NUMBER OF PROPELLANT.
- 8... GOVERNMENT EXPLOSIVE AND GROUP NUMBER.
- 9... **N.A.** DENOTING NAVAL ARMAMENT EXPLOSIVE FILLED STORE.
- 10... **TTT** DENOTING TROPICALISED PACKAGE.
- 11... **H.V.** DENOTING HIGH VELOCITY AMMUNITION.
- 12... PACKAGE SERIAL NUMBER.
- 13... CONTENTS LABEL.
- 14... STATION SEALING LABEL.
- 15... INSPECTION SEALING LABEL.

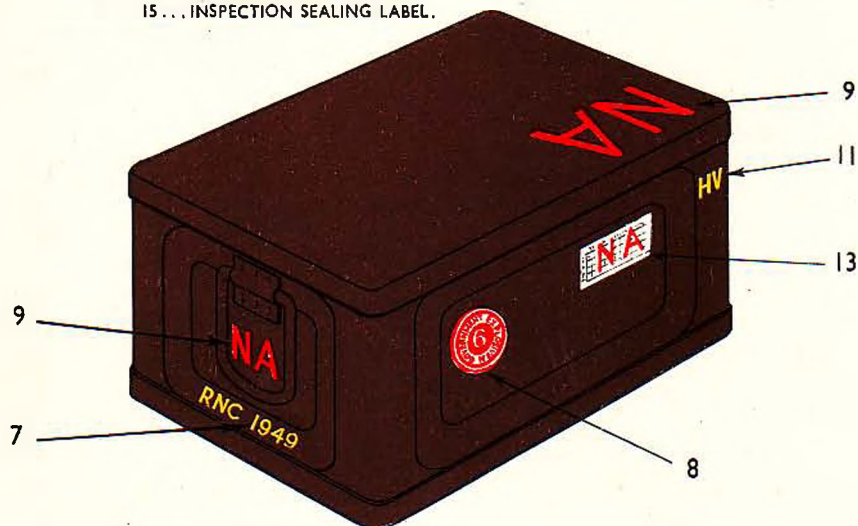

STENCILLING ON REVERSE SIDE AND END.

STEEL CONTAINER CONTAINING CHARGES (NAVAL SERVICE).

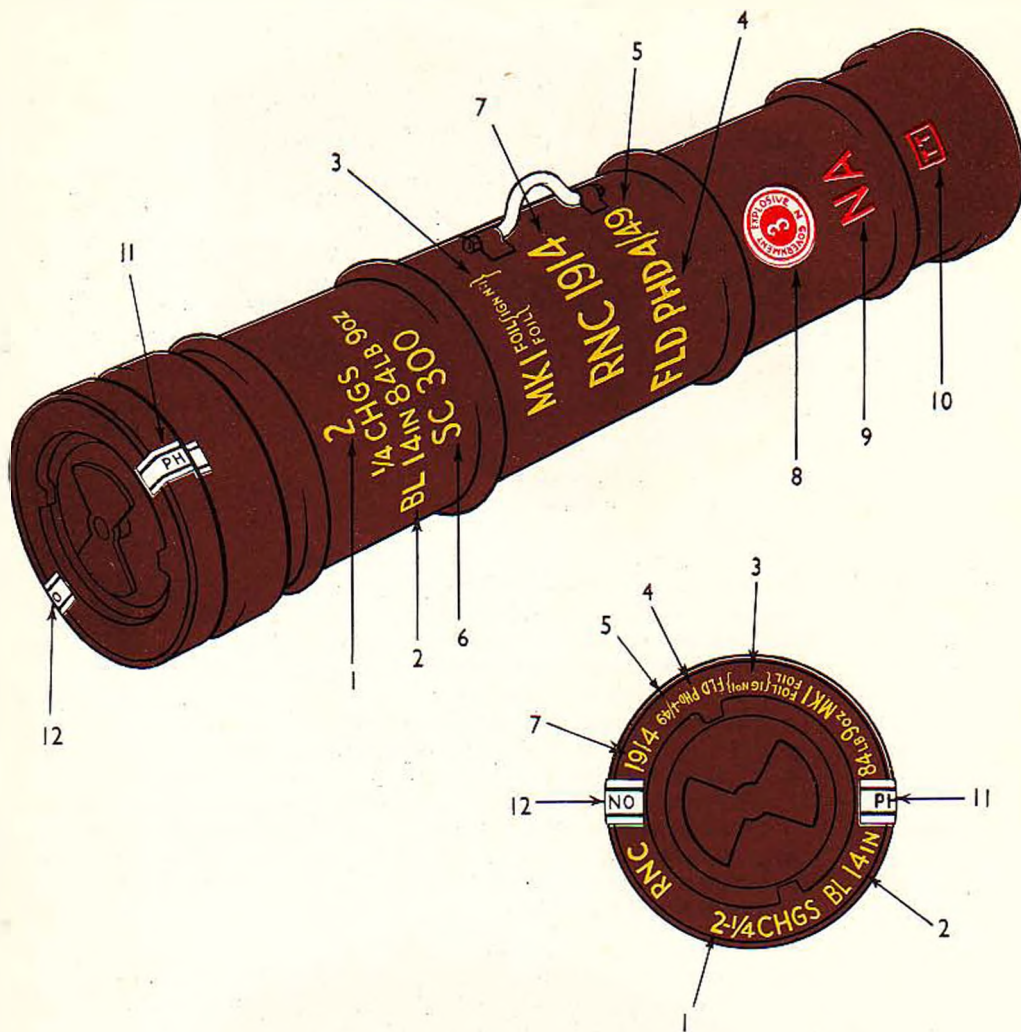

- 1.... QUANTITY OF ITEMS PACKED.
- 2.... DESIGNATION AND MARK OF THE COMPLETE STORE.
- 3.... DESIGNATION OF MAIN COMPONENTS AS APPLICABLE.
- 4.... FILLERS RECOGNIZED MARK OR INITIALS.
- 5.... DATE OF FILLING (MONTH AND YEAR).
- 6.... PROPELLANT IDENTIFICATION CODE.
- 7.... LOT NUMBER OF PROPELLANT.
- 8.... GOVERNMENT EXPLOSIVE AND GROUP NUMBER.
- 9.... **NA** DENOTING NAVAL ARMAMENT EXPLOSIVE FILLED STORE.
- 10.... **T** DENOTING TROPICALISED PACKAGE.
- 11.... STATION SEALING LABEL.
- 12.... INSPECTION SEALING LABEL.

STEEL BOX CONTAINING H.E. BATCHED AMMUNITION (LAND SERVICE).

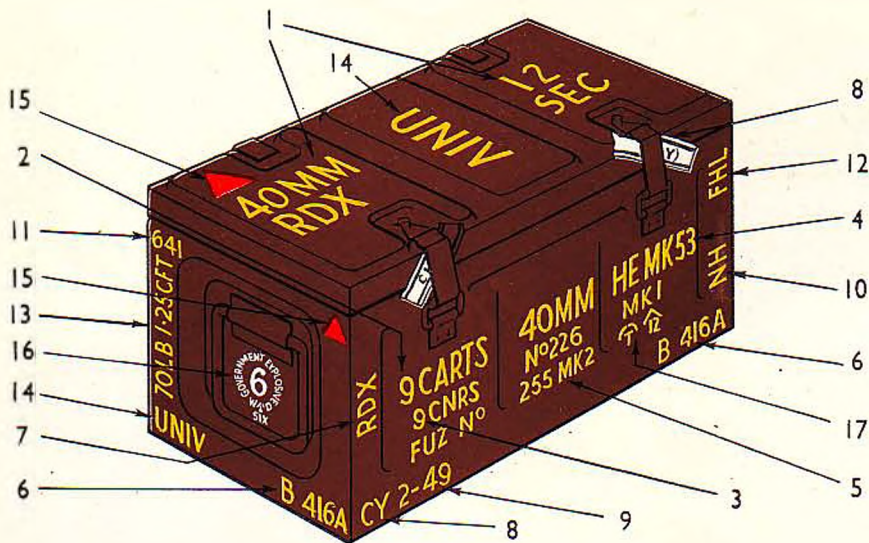

- | | |
|---|---|
| 1... OPERATIONAL MARKINGS. | 10... PROPELLANT IDENTIFICATION CODE. |
| 2... QUANTITY OF ITEMS PACKED. | 11... PACKAGE SERIAL NUMBER. |
| 3... QUANTITY OF INNER CONTAINERS AND TYPE
(WHERE APPLICABLE). | 12... FHL OR SML INDICATING FLASHLESS OR SMOKELESS
PROPELLANT CHARGE (WHERE APPLICABLE). |
| 4... DESIGNATION AND MARK OF THE STORE. | 13... GROSS WEIGHT (lb), VOLUME (cf). |
| 5... DESIGNATION AND MARK OF MAIN COMPONENTS
(WHERE APPLICABLE). | 14... TEMPERATURE AND CLIMATIC LIMITATIONS. |
| 6... BATCH NUMBER. | 15... ▲ UNSUITABLE FOR AIR-DROPPING
(WHERE APPLICABLE). |
| 7... NATURE OF FILLING OF SHELL AS APPLICABLE. | 16... GOVERNMENT EXPLOSIVE AND GROUP NUMBER. |
| 8... FILLERS RECOGNIZED MARK OR INITIALS. | 17... TRACER AND IGNITER SYMBOLS AS MARKED
ON PROJECTILE. |
| 9... DATE OF FILLING (MONTH AND YEAR). | 18... SEALING LABELS. |

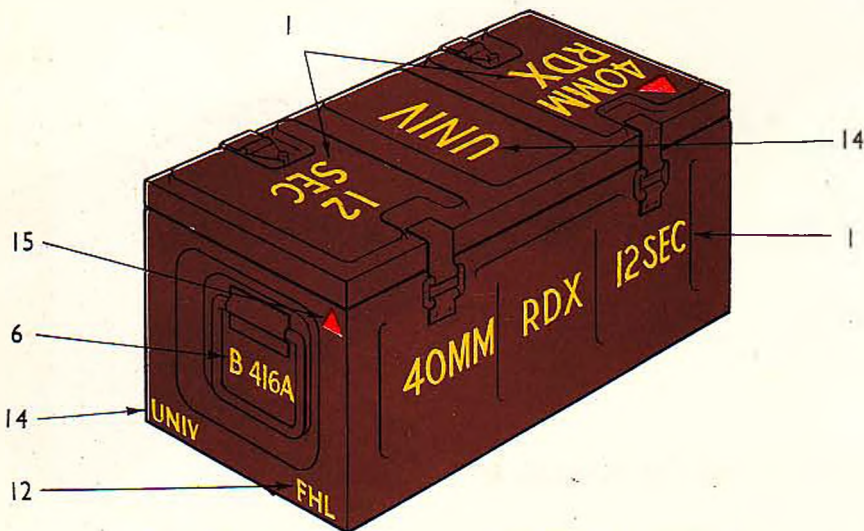

STENCILLING ON REVERSE SIDE AND END.

STEEL CONTAINER FOR SINGLE ROUND OF BATCHED AMMUNITION
(LAND SERVICE).

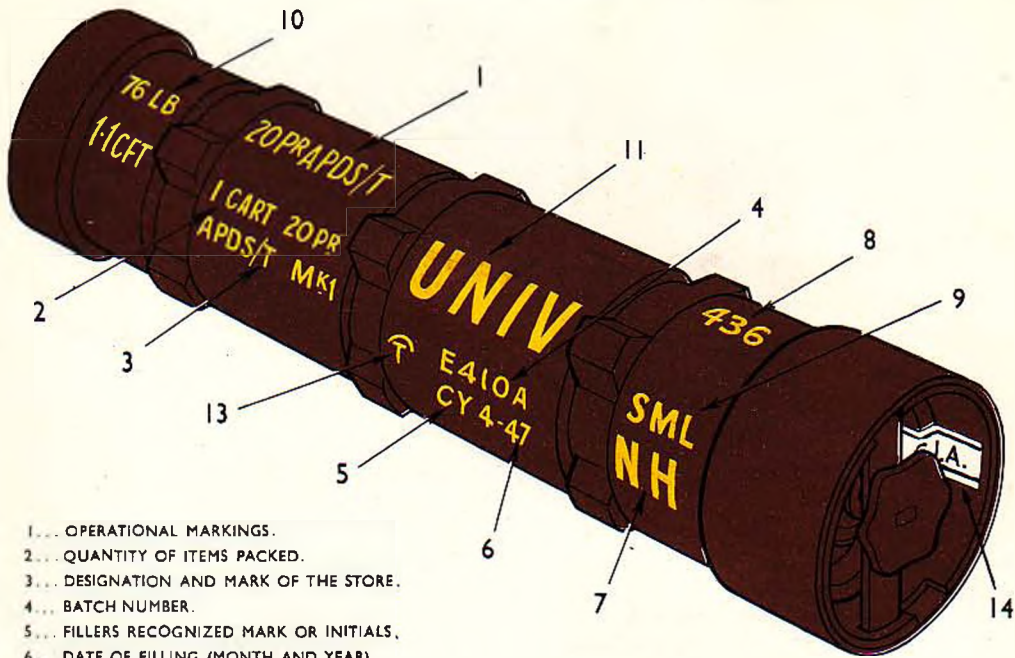

- 1... OPERATIONAL MARKINGS.
- 2... QUANTITY OF ITEMS PACKED.
- 3... DESIGNATION AND MARK OF THE STORE.
- 4... BATCH NUMBER.
- 5... FILLERS RECOGNIZED MARK OR INITIALS.
- 6... DATE OF FILLING (MONTH AND YEAR).
- 7... PROPELLANT IDENTIFICATION CODE.
- 8... PACKAGE SERIAL NUMBER.

- 9... FHL OR SML INDICATING FLASHLESS OR SMOKELESS PROPELLANT CHARGE (WHERE APPLICABLE).
- 10... GROSS WEIGHT (lb). VOLUME (cft).
- 11... TEMPERATURE AND CLIMATIC LIMITATIONS.
- 12... GOVERNMENT EXPLOSIVE AND GROUP NUMBER.
- 13... TRACER SYMBOL AS MARKED ON PROJECTILE.
- 14... SEALING LABELS.

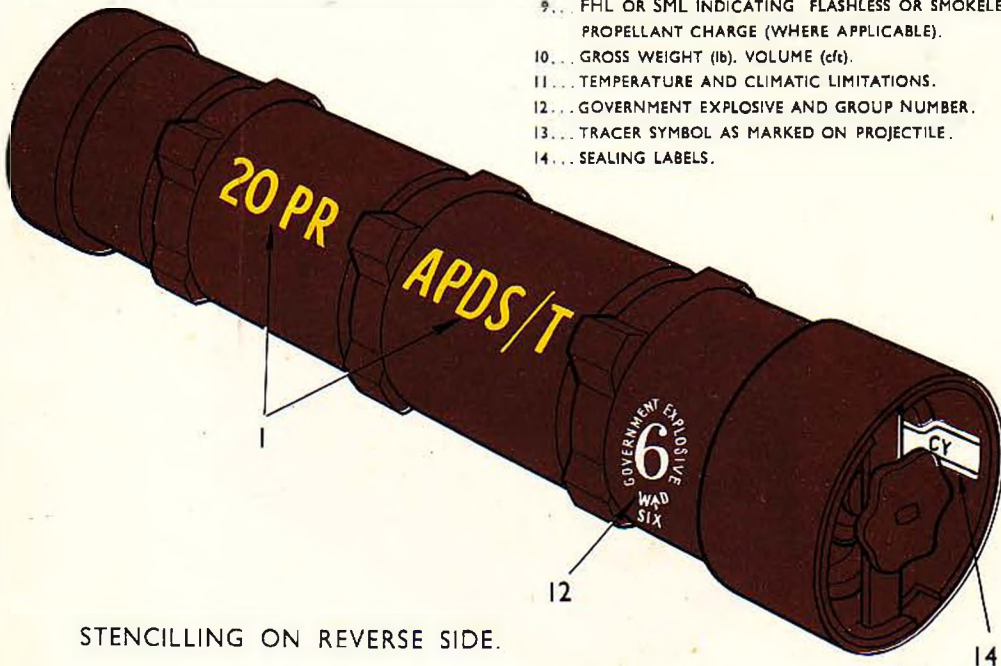

STENCILLING ON REVERSE SIDE.

STEEL CONTAINER FOR SINGLE SEPARATE LOADING CARTRIDGE
(LAND SERVICE).



- 1... OPERATIONAL MARKINGS.
- 2... QUANTITY OF ITEMS PACKED.
- 3... DESIGNATION AND MARK OF THE STORE.
- 4... DESIGNATION AND MARK OF MAIN COMPONENTS (WHERE APPLICABLE).
- 5... LOT NUMBER OF MAIN COMPONENT.
- 6... FILLERS RECOGNIZED MARK OF MAIN COMPONENT.
- 7... DATE OF FILLING (MONTH AND YEAR) OF MAIN COMPONENT.
- 8... LOT NUMBER OF PROPELLANT.
- 9... FHL OR SML INDICATING FLASHLESS OR SMOKELESS PROPELLANT CHARGE (WHERE APPLICABLE).
- 10... PROPELLANT IDENTIFICATION CODE AND SIZE.
- 11... FILLERS RECOGNIZED MARK OR INITIALS.
- 12... DATE OF FILLING (MONTH AND YEAR).
- 13... PACKAGE SERIAL NUMBER.
- 14... GROSS WEIGHT (lb). VOLUME (cft).
- 15... TEMPERATURE AND CLIMATIC LIMITATIONS.
- 16... GOVERNMENT EXPLOSIVE AND GROUP NUMBER.
- 17... SEALING LABELS.

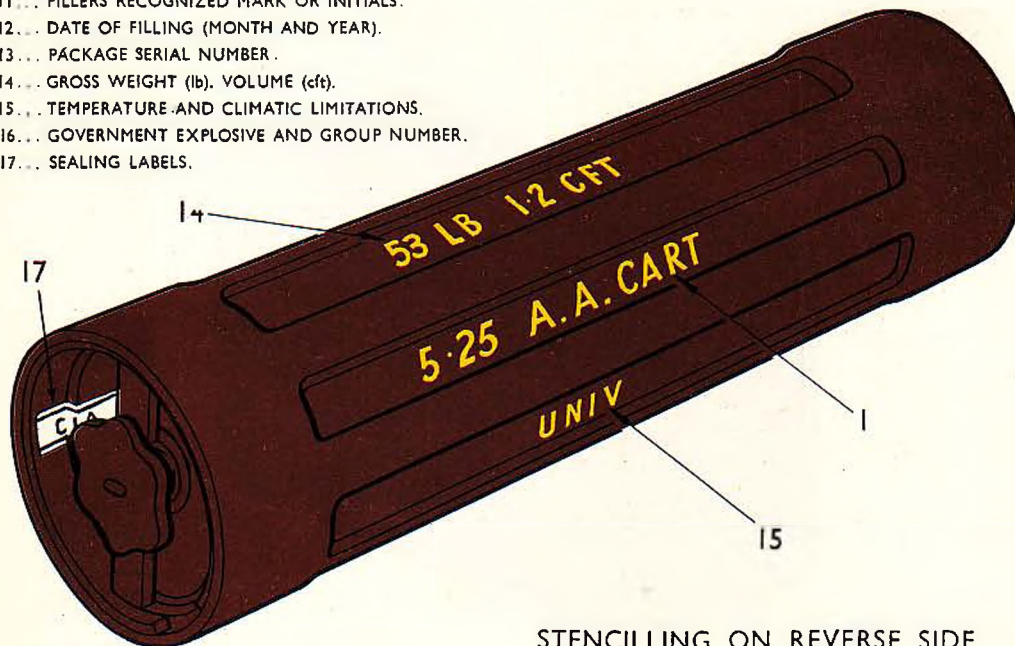

STENCILLING ON REVERSE SIDE.

STEEL BOX FOR SEPARATE LOADING Q.F. CARTRIDGES (LAND SERVICE).

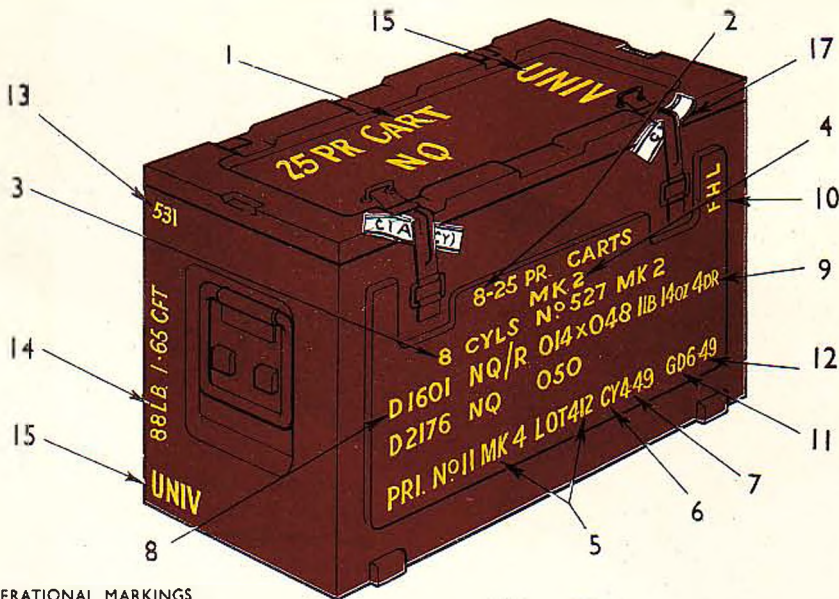

- | | |
|--|--|
| 1... OPERATIONAL MARKINGS. | 10... FHL OR SML INDICATING FLASHLESS OR SMOKELESS PROPELLANT CHARGE (WHERE APPLICABLE). |
| 2... QUANTITY OF ITEMS PACKED. | 11... FILLERS RECOGNIZED MARK OR INITIALS. |
| 3... QUANTITY OF INNER CONTAINERS AND TYPE (WHERE APPLICABLE). | 12... DATE OF FILLING (MONTH AND YEAR). |
| 4... DESIGNATION AND MARK OF THE STORE. | 13... PACKAGE SERIAL NUMBER. |
| 5... DESIGNATION, MARK AND LOT NUMBER OF MAIN COMPONENT. | 14... GROSS WEIGHT (lb). VOLUME (cft). |
| 6... FILLERS RECOGNIZED MARK OF MAIN COMPONENT. | 15... TEMPERATURE AND CLIMATIC LIMITATIONS. |
| 7... DATE OF FILLING (MONTH AND YEAR) OF MAIN COMPONENT. | 16... GOVERNMENT EXPLOSIVE AND GROUP NUMBER. |
| 8... LOT NUMBER, IDENTIFICATION CODE AND SIZE OF PROPELLANT. | 17... SEALING LABELS. |
| 9... NOMINAL CHARGE WEIGHT. | |

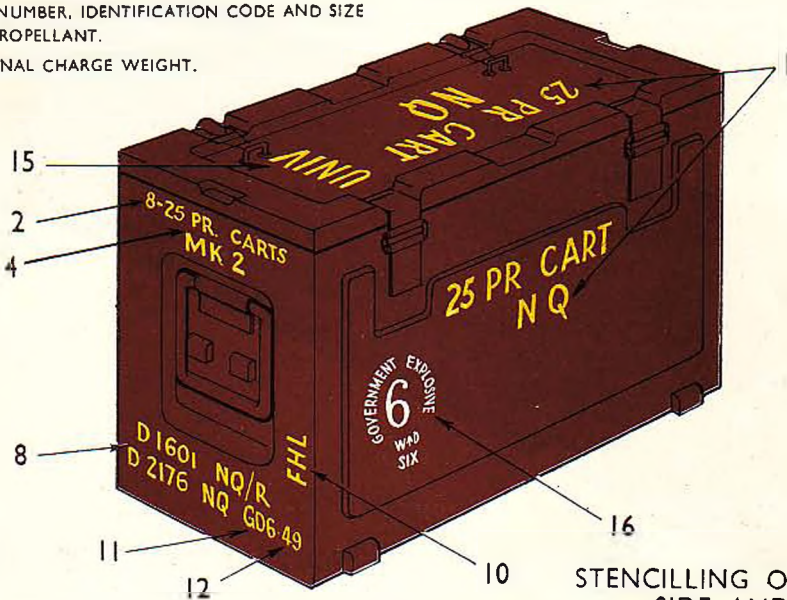

STENCILLING ON REVERSE SIDE AND END.

STEEL BOX FOR SEPARATE LOADING SHELL (LAND SERVICE).

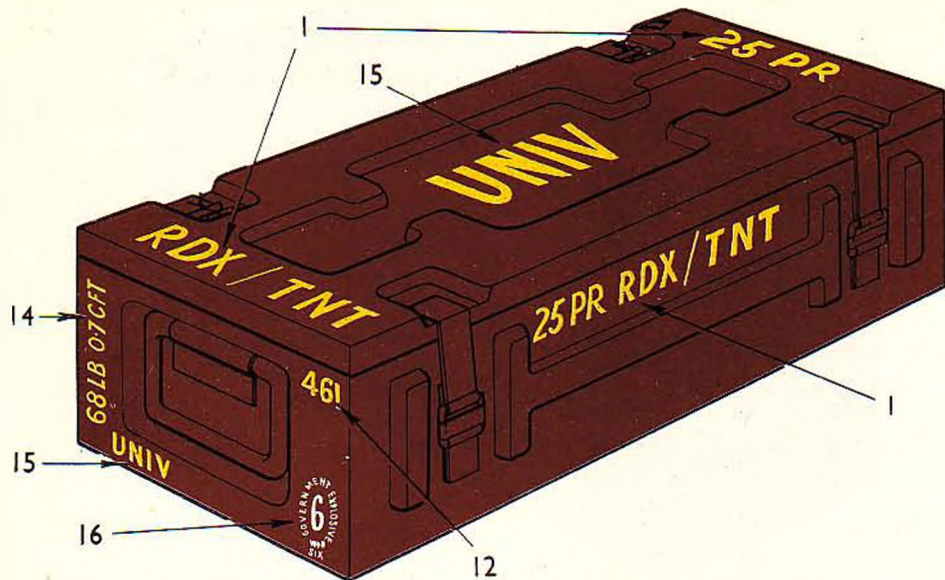

- | | |
|--|---|
| 1... OPERATIONAL MARKINGS. | 12... PACKAGE SERIAL NUMBER. |
| 2... QUANTITY OF ITEMS PACKED. | 13... "U" INDICATING "UNIVERSAL CAVITY" SHELL (WHERE APPLICABLE). |
| 3... DESIGNATION AND MARK OF THE STORE. | 14... GROSS WEIGHT (lb). VOLUME (cft). |
| 4... DESIGNATION AND MARK OF MAIN COMPONENTS (AS APPLICABLE). | 15... TEMPERATURE AND CLIMATIC LIMITATIONS. |
| 5... RECOGNIZED MARK OR INITIALS OF FILLER OF MAIN COMPONENT. | 16... GOVERNMENT EXPLOSIVE AND GROUP NUMBER. |
| 6... LOT NUMBER OF MAIN COMPONENT. | 17... SEALING LABELS. |
| 7... DATE OF FILLING (MONTH AND YEAR) OF MAIN COMPONENT. | 18... SMOKE BOX SYMBOL. |
| 8... SINGLE LINE CODE FOR METHOD OF FILLING AS STENCILLED ON PROJECTILE. | 19... FILLED SERIES NUMBER AS STENCILLED ON PROJECTILE. |
| 9... NATURE OF FILLING OF SHELL AS APPLICABLE. | |
| 10... FILLERS RECOGNIZED MARK OR INITIALS. | |
| 11... DATE OF FILLING (MONTH AND YEAR). | |

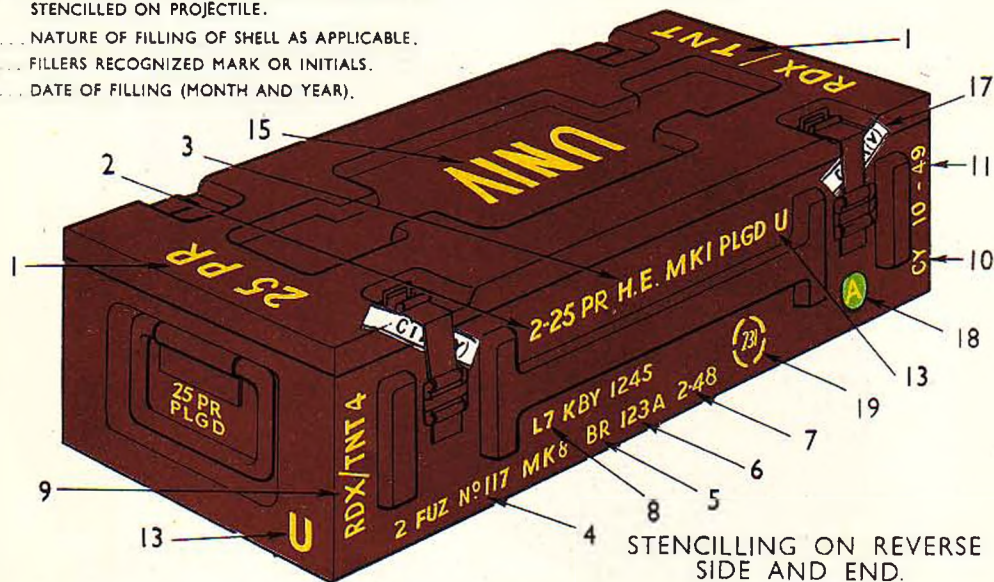

STENCILLING ON REVERSE SIDE AND END.

STEEL BOX FOR MISCELLANEOUS TYPES OF AMMUNITION (LAND SERVICE).

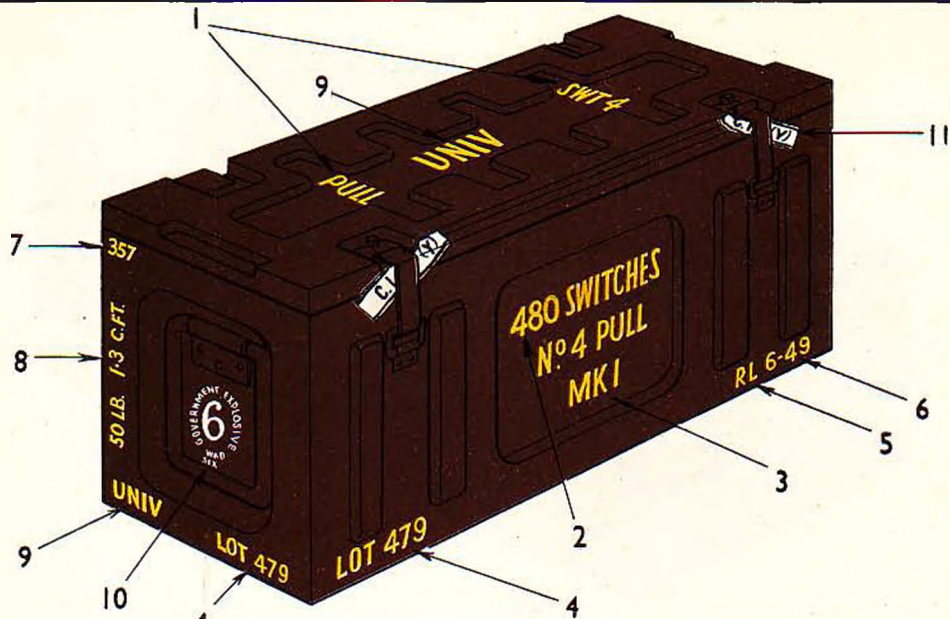

- 1... OPERATIONAL MARKINGS.
- 2... QUANTITY OF ITEMS PACKED.
- 3... DESIGNATION AND MARK OF THE STORE.
- 4... LOT NUMBER.
- 5... FILLERS RECOGNIZED MARK OR INITIALS.
- 6... DATE OF FILLING (MONTH AND YEAR).
- 7... PACKAGE SERIAL NUMBER.
- 8... GROSS WEIGHT (lb). VOLUME (cft).
- 9... TEMPERATURE AND CLIMATIC LIMITATIONS.
- 10... GOVERNMENT EXPLOSIVE AND GROUP NUMBER.
- 11... SEALING LABELS.

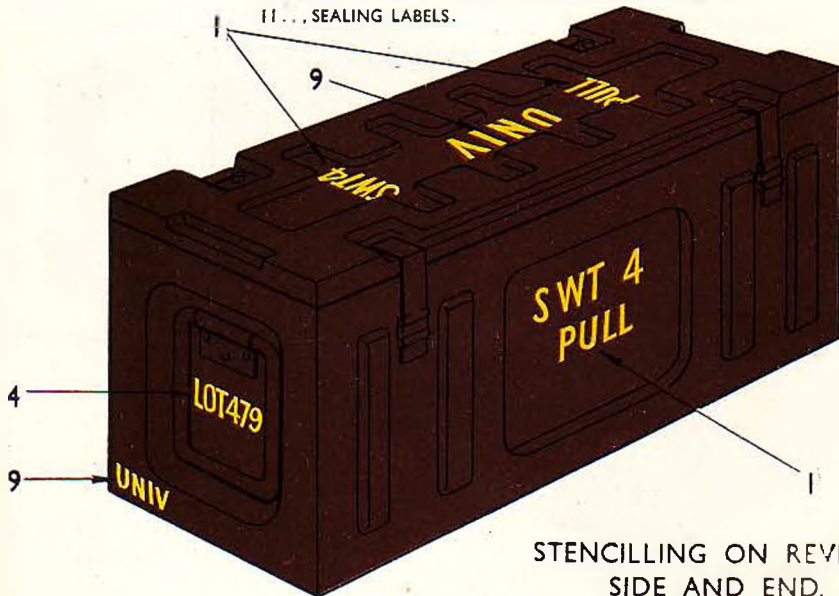

STENCILLING ON REVERSE
SIDE AND END.

STEEL BOX CONTAINING BULK PACKED FUZES (LAND SERVICE).

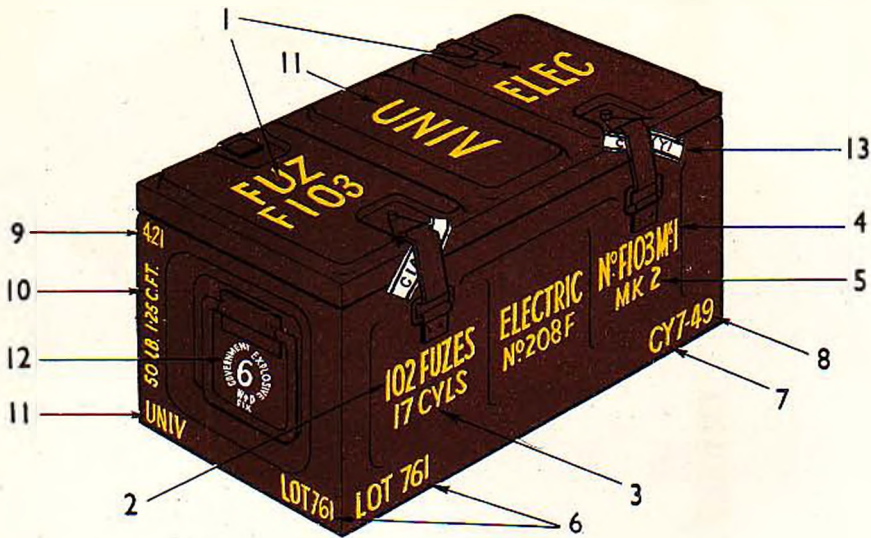

- | | |
|---|---|
| 1 ... OPERATIONAL MARKINGS. | 8 ... DATE OF FILLING (MONTH AND YEAR). |
| 2 ... QUANTITY OF ITEMS PACKED. | 9 ... PACKAGE SERIAL NUMBER. |
| 3 ... QUANTITY OF INNER CONTAINERS AND TYPE (WHERE APPLICABLE). | 10 ... GROSS WEIGHT (lb), VOLUME (cft). |
| 4 ... DESIGNATION AND MARK OF THE STORE. | 11 ... TEMPERATURE AND CLIMATIC LIMITATIONS. |
| 5 ... DESIGNATION AND MARK OF INNER CONTAINERS. | 12 ... GOVERNMENT EXPLOSIVE AND GROUP NUMBER. |
| 6 ... LOT NUMBER. | 13 ... SEALING LABELS. |
| 7 ... FILLERS RECOGNIZED MARK OR INITIALS. | |

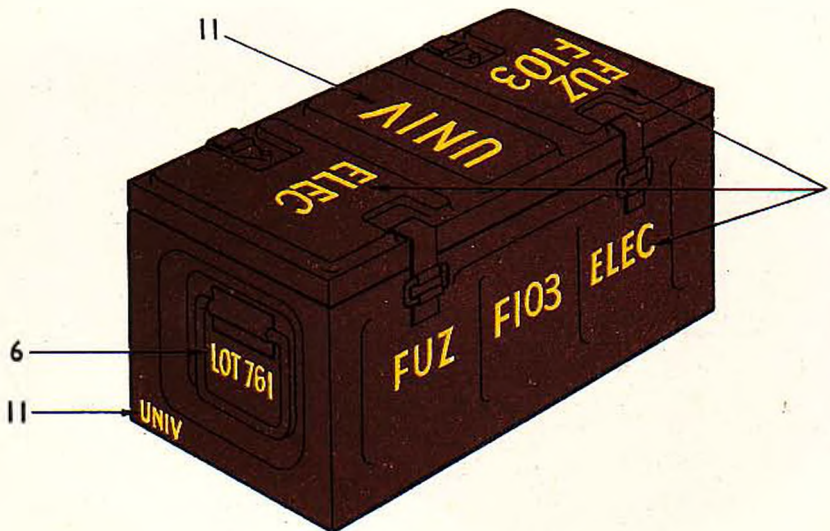

STENCILLING ON REVERSE SIDE AND END.

TYPICAL STEEL BOX CONTAINING CHEMICAL SHELL (LAND SERVICE).

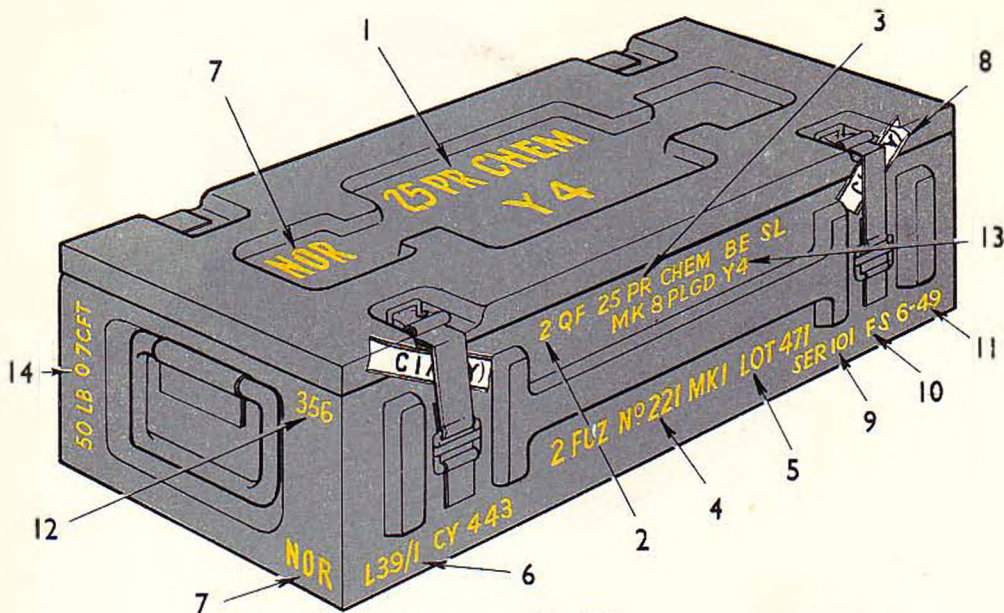

- | | |
|--|---|
| 1... OPERATIONAL MARKINGS. | 9... BODY CHARGING LOT NUMBER. |
| 2... QUANTITY OF ITEMS PACKED. | 10... RECOGNIZED MARK OR INITIALS OF BODY CHARGING STATION. |
| 3... DESIGNATION AND MARK OF THE STORE. | 11... DATE OF BODY CHARGING (MONTH AND YEAR). |
| 4... DESIGNATION AND MARK OF MAIN COMPONENT (AS APPLICABLE). | 12... PACKAGE SERIAL NUMBER. |
| 5... LOT NUMBER OF MAIN COMPONENT. | 13... NATURE OF CHARGING. |
| 6... SINGLE LINE CODE IDENTIFYING HEAD FILLING. | 14... GROSS WEIGHT (lb), VOLUME (cft). |
| 7... TEMPERATURE AND CLIMATIC LIMITATIONS | 15... GOVERNMENT EXPLOSIVE AND GROUP NUMBER. |
| 8... SEALING LABELS | |

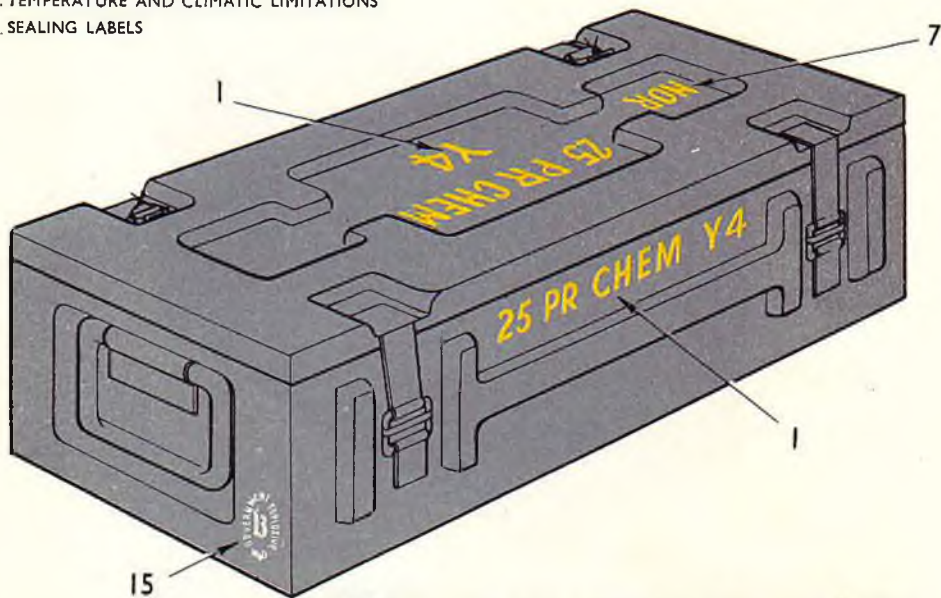

STENCILLING ON REVERSE SIDE AND END.

INNER CONTAINERS AND CYLINDERS (LAND SERVICE).

CONTAINER STENCILED UNDER THE BATCHING SYSTEM.



- 1... QUANTITY OF ITEMS PACKED.
- 2... DESIGNATION AND MARK OF THE STORE.
- 3... BATCH NUMBER.
- 4... DESIGNATION AND MARK OF CONTAINER.
- 5... CONTRACTORS RECOGNIZED MARK OR INITIALS OF CONTAINER.
- 6... DATE OF MANUFACTURE (MONTH AND YEAR).

CYLINDER STENCILED UNDER THE UNBATCHED SYSTEM.



- 1... QUANTITY OF ITEMS PACKED.
- 2... DESIGNATION AND MARK OF THE STORE.
- 3... LOT NUMBER AND PROPELLANT IDENTIFICATION CODE.
- 4... FILLERS RECOGNIZED MARK OR INITIALS.
- 5... DATE OF FILLING (MONTH AND YEAR).
- 6... FHL OR SML INDICATING FLASHLESS OR SMOKELESS PROPELLANT CHARGE (WHERE APPLICABLE).

AMMUNITION BOX CONTAINING FLAME STORES (AIR SERVICE).

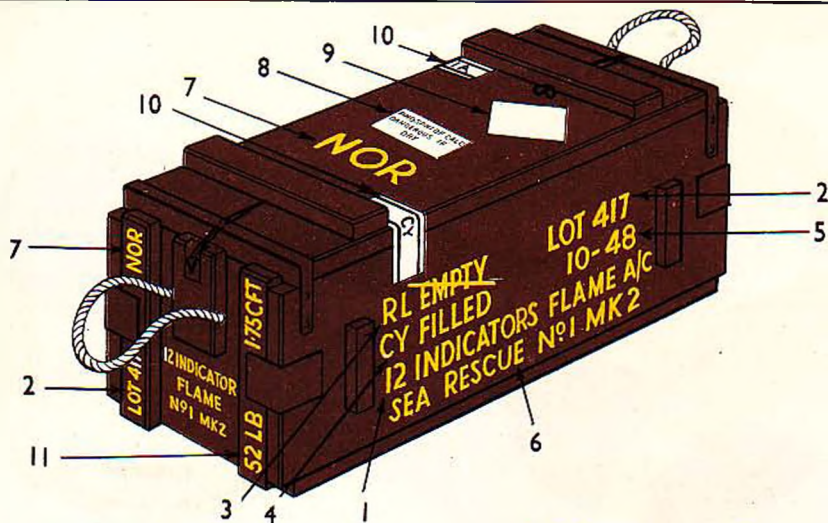

- | | |
|---|--|
| 1... QUANTITY OF ITEMS PACKED. | 6... DESIGNATION AND MARK OF STORE. |
| 2... LOT NUMBER. | 7... TEMPERATURE AND CLIMATIC LIMITATIONS. |
| 3... CONTRACTORS RECOGNIZED MARK OR INITIALS MAKING EMPTY INDICATORS. | 8... DESCRIPTIVE LABEL. |
| 4... FILLERS RECOGNISED MARK OR INITIALS. | 9... DANGEROUS GOODS LABEL. |
| 5... DATE OF FILLING (MONTH AND YEAR). | 10... SEALING LABELS. |
| | 11... GROSS WEIGHT (lb). VOLUME (cft). |

AMMUNITION BOX CONTAINING DETONATORS (AIR SERVICE).

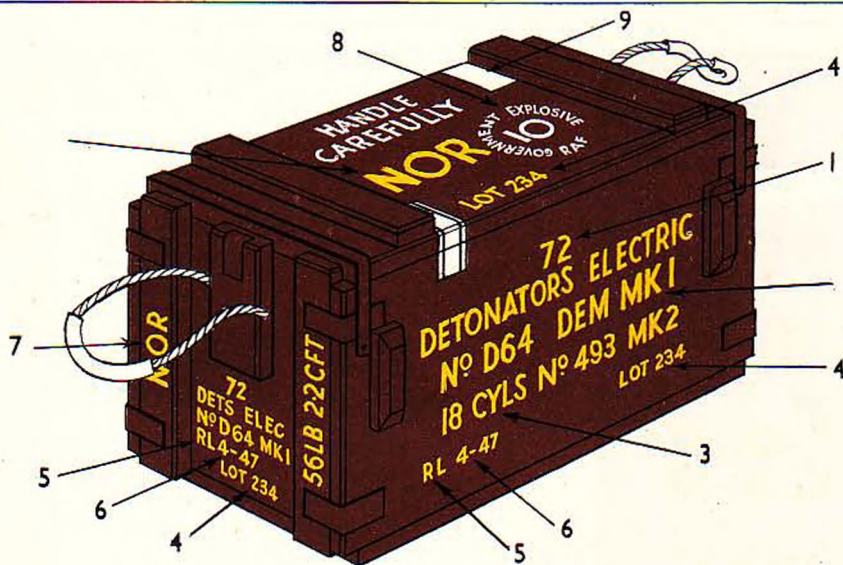

- | | |
|---|---|
| 1... QUANTITY OF ITEMS PACKED. | 6... DATE OF FILLING (MONTH AND YEAR). |
| 2... DESIGNATION AND MARK OF STORE. | 7... TEMPERATURE AND CLIMATIC LIMITATIONS. |
| 3... QUANTITY OF INNER CONTAINERS AND TYPE. | 8... GOVERNMENT EXPLOSIVE AND GROUP NUMBER. |
| 4... LOT NUMBER. | 9... SEALING LABELS. |
| 5... FILLERS RECOGNIZED MARK OR INITIALS. | 10... GROSS WEIGHT (lb). VOLUME (cft). |

CYLINDER CONTAINING AIRCRAFT BOMB DETONATORS (AIR SERVICE).

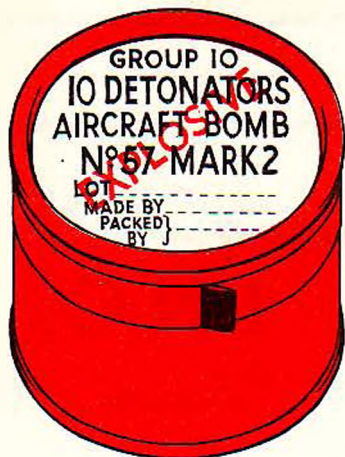

SERVICE.

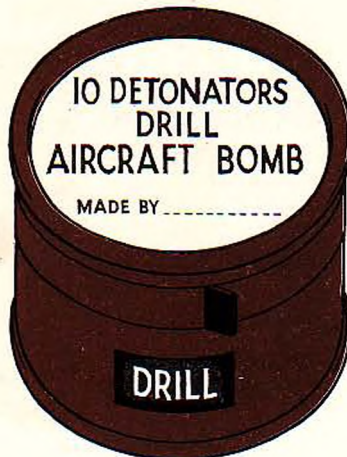

DRILL.

TYPICAL AMMUNITION LABELS (LAND AND AIR SERVICE).



INSPECTION LABEL.



STATION LABEL.



COMPOSITE INSPECTION AND
STATION LABEL.

L.566.A. 51-6208

Filled at _____ / /

Packed by _____

Soldered by _____

Examined & } _____ / /

Re-packed at }

Packed by _____

Soldered by _____

PACKERS LABEL.

L. 423B.

24 CART^{GES.} Q.F., 40 M.M. H.E. SHELL Mk _____

BATCH. B. _____ **FILLED.** _____

Propellant..... Lot.....

Primer No..... Mk..... Filled..... Lot.....

Shell, Q.F., H.E. Mk..... Filled..... Design.....

Igniter Tracer, Mk..... Filled..... Lot.....

Tracer, and Igniter No..... Mk..... Filled..... Lot.....

Fuze, Percn. D.A.No..... Mk..... Filled..... Lot.....

BATCH LABEL (LAND SERVICE ONLY).

GOVERNMENT EXPLOSIVE AND GROUP LABELS.



GOVERNMENT EXPLOSIVE AND
GROUP LABEL
(NAVAL SERVICE).



GOVERNMENT EXPLOSIVE AND
COMPOSITE GROUP LABEL
(NAVAL SERVICE).



GOVERNMENT EXPLOSIVE AND GROUP LABEL
(LAND SERVICE).



GOVERNMENT EXPLOSIVE AND GROUP LABEL
(AIR SERVICE).

TYPICAL DANGEROUS GOODS LABELS.

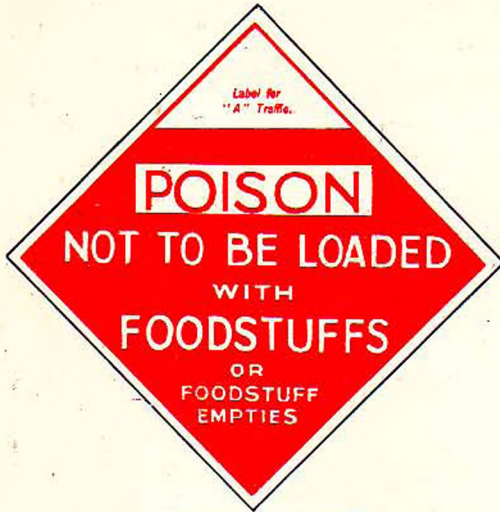

LABEL FOR "A" TRAFFIC.



LABEL FOR "B" TRAFFIC.



LABEL FOR "C" TRAFFIC.



LABEL FOR "D" TRAFFIC.



LABEL FOR "E" TRAFFIC.



LABEL FOR "F" TRAFFIC.

RESTRICTED

The information given in this document is not to be
communicated, either directly or indirectly, to the
Press or to any person not authorized to receive it

W.O.
CODE No.
1803

**INTER-SERVICE
AMMUNITION AND
AMMUNITION PACKAGE
MARKINGS
SECTION 5 (PART 2)
PACKAGES S.A.A.**

1953

This Section, having been approved by the Lords Commissioners of the Admiralty, by the Army Council and by the Air Council, is promulgated for information and guidance.

By Command of their Lordships

J. G. Lang

By Command of the Army Council

G. W. Turner

By Command of the Air Council

J. H. Barwell

CONTENTS

Introduction	Para.
Methods of marking	1
Colour markings	2
Stencilling	3
Stamping, embossing and branding	4
Labels	5
Strip bands and bundle wrappers	6
Operational markings—abbreviations	7

LIST OF PLATES

	Plate
Box A.S.A. H.50 Typical Outer package—Land Service	1
Box A.S.A. H.50 Typical Outer package—Land Service	2
Box A.S.A. H.51 Typical Inner package—Land Service	Fig. 1. 3
Box A.S.A. H.52 Typical Inner package—Tinned-plate box Land Service	Fig. 2. 3
Box A.S.A. H.47 Typical Outer package—Air Service	4
Box A.S.A. H.54 Typical Outer package—Air Service	5
Box A.S.A. H.60 Typical Outer package—Air Service	6

INDEX

	Para.	Page
A		
A.S.A.—operational abbreviations	7	9
B		
Branding of boxes	4	7
Bullethead blank—marking of packages	2.1	5
Bundle wrappers	6.2	8
C		
Classification group—labels or stencils	5	7
Climatic limitations—marking of	3.6.2	6
Colour markings—Outer packages	2.1	5
Colour markings—Inner packages	2.2	5
Colour markings—Tinned-plate boxes, cylinders or linings	2.3	5
Colour of labels	5.6	8
Colour of stencilling	3.3	5
D		
Descriptive labels	5.3	8
Distinguishing labels	5.2	7
E		
Embossing of liners	4	7
Empty packages—marking of	4.1	7

INDEX—contd.

	Para.	Page
G		
Government explosive classification group labels	5.1	7
I		
Inner packages—colour of	2.2	5
Inner packages—particulars required on	3.7	6
Inspection sealing labels	5.4	8
L		
Labels	5	7
Linings or liners—colour of	2.3	5
M		
Metal seals—use of	5.4.2	8
Methods of marking	1	5
N		
Nomenclature—abbreviations	{ 3.1 7	5 9
Nomenclature—size of stencilling	3.4	5
Nomenclature—markings—position of	3.5.3	6
O		
Operational marking—abbreviations	{ 7 3.2	9 5
Operational marking—position of	3.5.2	6
Outer-packages—particulars required on	3.6	6
P		
Packages—colour of	2	5
Position of stencilling	3.5	6
R		
Restricted use—labels	5.5	8
Restricted use—markings	{ 3.6.2 3.9.2	6 7
S		
Sealing labels—use of	5.4	8
Size of stencilling	3.4	5
Stamping on boxes	4	7
Stencilling	3	5
Stencilling—colour	3.3	5
Stencilling—nomenclature	3.1	5
Stencilling—operational markings	3.2	5
Stencilling—size	3.4	5
Stencilling—position of	3.5	6
Strip bands	6.1	8
T		
Tinned-plate boxes or cylinders—particulars stencilled on	3.8	6

RESTRICTED

INTRODUCTION

1. METHODS OF MARKING

The methods of marking in this Section conform to those laid down in Section 1, General Introduction, which should be read in conjunction with this Section.

They consist of:—

- Colour markings.
- Stencilling.
- Stamping, embossing and branding.
- Labels.
- Strip bands and bundle wrappers.

2. COLOUR MARKINGS

2.1. *Outer Packages*

All outer packages will be painted in a basic body colour of camouflage Brown. Packages containing bulleted blank will be painted with a 2 inch Yellow band for ready identification and for the safety of troops.

2.2. *Inner Packages*

Inner packages are normally painted camouflage Brown.

2.3. *Tinned-plate Boxes, Cylinders or Linings*

These are usually painted or varnished Black for protection purposes. The colour has no significance.

3. STENCILLING

Examples of stencilling on typical packages are given on Plates 1 to 6. Stencilling on packages is intended to provide the user and the storeholder with the necessary information relating to the contents.

3.1. *Nomenclature*

The approved abbreviated nomenclature and mark of the contents.

3.2. *Operational Markings*

In Land Service, additional details known as "Operational markings" are used. These consist of boldly stencilled abbreviations which enable the user in an operational area to identify quickly the store he requires. Operational markings are not used with Practice, Blank and Drill stores.

3.3. *Colour*

Normally Yellow paint is used for stencilling on packages. All Operational and Explosive Group Classification stencilling is in White; component details in Yellow; and restrictive sentence in Red.

3.4. *Size*

The size of stencilling varies with the dimensions of the package. The following sizes are suggested as a guide:—

- Operational markings ... normally 2 inches.
- Nomenclature markings ... normally $1\frac{1}{2}$ inches.
- Component details ... normally $\frac{1}{2}$ inch and $\frac{1}{4}$ inch according to the size of the package, but not larger than $\frac{3}{4}$ inch.

In the case of small packages on which space is restricted, the markings will be of convenient sizes in approximately the same relative proportions.

3.5. *Position*

- 3.5.1. The position of stencilling on packages depends on various factors such as:—
Operational requirements.
Design of package.
Method of stacking or stowage.
Particulars of contents, etc.
- 3.5.2. Operational markings, when used, are stencilled on the top and on the opposite side to that bearing the nomenclature, quantities packed, etc.
- 3.5.3. Nomenclature markings are usually stencilled on the lid or top (when operational markings are not employed) and on one side when the shape of the package permits.
- 3.5.4. Markings sufficient to identify the contents, together with the date of work, should, so far as circumstances permit, be stencilled on the ends of packages. This will enable ready identification to be made when, for reasons of economy in storage space, packages are stacked ends outwards.

3.6. *Particulars on Outer Packages*

- 3.6.1. The following particulars are normally stencilled on steel boxes, and may also be stencilled on wood boxes as an alternative to labels (*see* also para. 5.2.).
Number of rounds.
Nomenclature and mark.
Method of packing.
*Date of work (filling assembly).
Maker's recognized mark or initials.
Lot number (if applicable).
Box serial number.
Government explosive group number.
- 3.6.2. The following particulars may also be stencilled on outer packages when specially required:—
Operational marking.
Restricted used (in Red) (when applicable).
Climatic limitations (*see* Section 5, Part 1, para. 3.9.1.).

3.7. *Particulars on Inner Packages*

- 3.7.1. When ammunition is packed in closed inner packages which may be removed from their outer package, each inner package will normally be stencilled with the following particulars:—
Number of rounds.
Nomenclature and mark.
Method of packing.
*Date of work (filling assembly).
Maker's recognized mark or initials.
Restricted use (in Red) (when applicable).
Box serial number.

3.8. *Particulars on Tinned-plate Boxes or Cylinders*

- When ammunition is packed in sealed tinned-plate boxes or cylinders which are removed from their package, each will normally be stencilled with the following:—
Number of rounds.
Nomenclature and mark.
Date of work (filling assembly).
Maker's recognized mark or initials.

3.9. *Additional Stencilling*

- 3.9.1. *Government Explosive Group Classification*
This will be stencilled on each outer package containing explosives (*see* paras. 5.1. and 5.1.2.). The colour will be White on basic colour background.

3.9.2. *Restricted Use*

Packages which in abnormal circumstances contain ammunition sentenced for restricted use before issue to the Service will be stencilled or bear a label indicating the special nature of restriction (*see* para. 5.5).

3.9.3. *For individual Services*

Additional stencilling, usually of a self-explanatory nature, is sometimes applied by individual Services for a particular purpose. In Air Service a diagonal Blue band is placed on all stores intended for overseas shipment.

**Note.*—This will be followed by a suffix letter if more than one lot is produced with the same date.

4. STAMPING, EMBOSSED AND BRANDING

4.1. *Empty Packages*

Empty packages usually have the following particulars stamped, embossed or branded by the maker:—

Box letter, number and mark, *e.g.*, H.52 Mk. 1.

Maker's recognized mark or initials.

Year of manufacture.

Stores reference number (Air Service only).

On metal packages this information is embossed, on wooden packages it is stamped or branded.

5. LABELS

5.1. *Government Explosive Classification Group Label*

Packages containing stores classified for storage and transport in an Explosives Group are labelled with a group label carrying a group number which denotes the conditions under which the package is to be transported and stored (*see* Comprehensive Classified List of Government Explosives).

5.1.1. The government explosive group label used in each Service is as follows:—

Naval Service Red on White background, with "N" to indicate Naval Service.

Where items may be allocated to different groups on board and ashore, a *composite group label* is used indicating the shore group in the denominator.

Land Service Red on White background, with "W ↑ D" to indicate Land Service.

Air Service Red on White background with "RAF" to indicate Air Service.

Ministry of Supply ... Red on White background with "MOS" to indicate Ministry of Supply.

(For illustration *see* Section 5, Part 1, Plate 16.)

5.1.2. Where desired the Explosive Group may be stencilled in White on the basic body colour background.

5.2. *Distinguishing Labels* (where stencilling is not adopted)

Large size labels are placed on each side of the outer packages and small ones on each end.

The large labels will have the following printed on them:—

Number of rounds

Nomenclature and mark

Method of packing

Distinguishing symbol

Overprint of code letter and mark in Black.

} in appropriate colours, *see* para. 5.6.

The small labels will have the following printed on them:—

Calibre and nature
Method of packing
Distinguishing symbol
Overprint of code letter and mark in Black.

} in appropriate colours, *see* para. 5.6.

5.3. *Descriptive Labels* (where stencilling is not adopted)

These labels are placed on the top of outer packages, inner packages, containers and linings and have the following information printed on them:—

Number of rounds.
Nomenclature and mark.
Method of packing.
Maker's recognized mark or initials and date of work (filling assembly).

5.4. *Inspection Sealing Labels*

Packages containing explosives and explosive filled stores are normally sealed with a muslin sealing label bearing the monogram of the station carrying out the packing. Unbroken labels indicate that the package has not been opened since last examination or inspection.

5.4.1. Two labels are normally used and are affixed in such a position that the package cannot be opened without breaking the seal so formed.

5.4.2. As an alternative, packages may be sealed with soft metal seals stamped with the appropriate monogram.

5.5. *Restricted Use* (where stencilling is not adopted)

These labels indicate briefly the nature of the restriction, *e.g.*, "For machine guns only", etc.

5.6. *Colour of Labels* (where stencilling is not adopted)

For rapid identification and sorting of the type, nature and mark of ammunition packed, labels are printed in coloured inks on coloured paper as shown below:—

Ammunition in explosive—

Classification group 6	Green Ink on White paper.
Classification group 12	Brown Ink on White paper.
Blank ammunition	Red Ink on Blue paper.
Proof ammunition (Not a Service store) ...	Black Ink on Terra Cotta paper.
Non-explosive ammunition, <i>i.e.</i> , drill ...	Black Ink on Cerise paper.

Restrictive labels are normally printed in Red Ink on White paper.

6. STRIP BANDS AND BUNDLE WRAPPERS

6.1. *Strip Bands*

Cartons containing S.A.A. are sealed with strip bands which have the following information printed on them:—

Number of rounds,
nomenclature and mark,
and are stamped with the maker's recognized mark (or initials) and date of work (filling assembly).

6.2. *Bundle Wrappers*

Ammunition in bundle packs will have the following information printed on the wrapper:—

Number of rounds,
nomenclature and mark,
and are stamped with the maker's recognized mark (or initials) and date of work (filling assembly).

7. OPERATIONAL MARKINGS ON S.A.A. PACKAGES

Calibre and Nature of Ammunition	Abbreviations
Cartridges, S.A. .30 inch Belted	30-IN BLT
Cartridges, S.A. .30 Ball Carton Packed	30-IN CTN
Cartridges, S.A. .30 Incendiary Carton Packed	30-IN INC CTN
Cartridges, S.A. .30 Tracer Carton Packed	30-IN TRA CTN
Cartridges, S.A. .30 A.P. Carton Packed	30-IN AP CTN
Cartridges, S.A. .303 inch A.P.	303 AP
Cartridges, S.A. .303 inch Ball, Bandoliers	303 BDR
Cartridges, S.A. .303 inch Ball, Cartons	303 CTN
Cartridges, S.A. .303 inch Tracer 2	303 TRA
Cartridges, S.A. .303 inch Tracer 7 Carton Packed	303 TRA 7
Cartridges, S.A. .303 inch Incendiary 7z	303 INC 7z
Cartridges, S.A. .303 inch Incendiary 7	303 INC 7
Cartridges, S.A. .303 inch Observing	303 OBS
Cartridges, S.A. .303 inch Ball 7 Stripless Belts	303 BLT 7
Cartridges, S.A. .303 inch Ball 8z Stripless Belts	303 BLT 8z
Cartridges, S.A. .303 inch Ballistite, H, Mk. 1Z	303 BLST
Cartridges, S.A. .380 inch Revolver Ball	380 REV
Cartridges, S.A. 7.92 mm. Belted	792 BLT
Cartridges, S.A. 7.92 mm. Ball, Cartons	792 CTN
Cartridges, S.A. 7.92 mm. Ball Bandolier Packed	792 BDR
Cartridges, S.A. 7.82 mm. Incendiary Carton Packed	792 INC CTN
Cartridges, S.A. 7.92 mm. A.P. Carton Packed	792 AP CTN
Cartridges, S.A. 7.92 mm. Tracer. Cartons	792 TRA CTN
Cartridges, S.A. 9 mm. Parabellum Ball	9 MM
Cartridges, S.A. .45 inch Ball, Rimless	45 AUTO
Cartridges, S.A. .455 inch Ball Revolver	455 REV
Cartridges, S.A. .50 inch Browning Belted A.P. Tracer and Incendiary Mixed	50 BROWN BLT
Cartridges, S.A. .50 inch Browning Ball in Cartons	50 BROWN
Cartridges, S.A. .50 inch Browning Belted A.P. and Incendiary Mixed	50 BROWN BLT API
Cartridges, S.A. .50 inch Browning Incendiary in Carton	50 BROWN INC
Cartridges, S.A. .50 inch Browning Belted A.P. and Tracer Mixed	50 BROWN BLT APT
Cartridges, S.A. .50 inch Browning Tracer in Carton	50 BROWN TRA
Cartridges, S.A. 20 mm. Oerlikon H.E./I	20 MM HEI
Cartridges, S.A. 20 mm. Oerlikon H.E./I/T	20 MM HEIT
Cartridges, S.A. 20 mm. Oerlikon H.E./T	20 MM HET
Cartridges, S.A. 20 mm. Oerlikon H.E./I/T/SD	20 MM SDHEIT
Cartridges, S.A. 20 mm. Oerlikon S.A.P./H.E./I	20 MM SAP HEI
Cartridges, S.A. Inspection	INSP
Igniter, Flame Thrower No. 1, Mk. 1	IGN ACK PACK

BOX A.S.A. H. 50 (TYPICAL OUTER PACKAGE - LAND SERVICE)

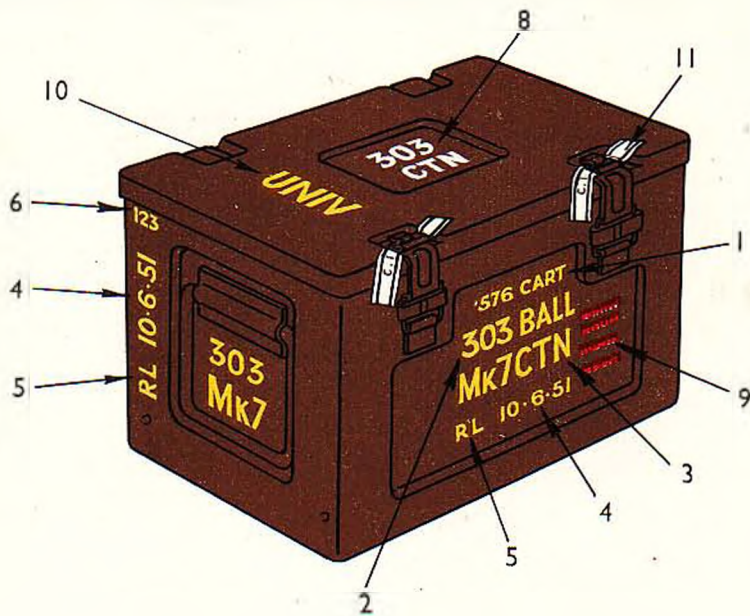

- | | |
|---|---|
| 1.. NUMBER OF ROUNDS | 7.. GOVERNMENT EXPLOSIVE GROUP (LABEL OR STENCIL) |
| 2.. NOMENCLATURE AND MARK | 8.. OPERATIONAL MARKINGS |
| 3.. METHOD OF PACKING | 9.. RESTRICTED USE (WHEN APPLICABLE) |
| 4.. DATE OF WORK (FILLING ASSEMBLY) | 10.. TEMPERATURE AND CLIMATIC LIMITATIONS |
| 5.. MANUFACTURERS RECOGNIZED MARK OR INITIALS | 11.. INSPECTION SEALING LABELS |
| 6.. BOX SERIAL NUMBER | |

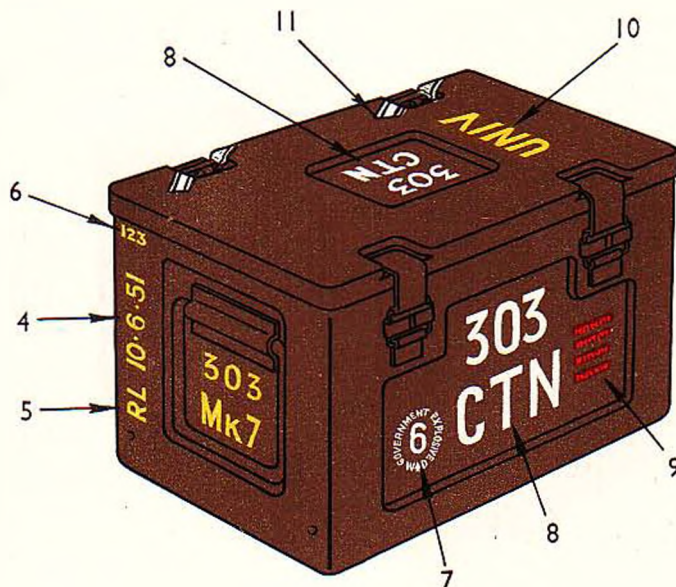

REVERSE SIDE AND END

BOX A.S.A. H. 51 (TYPICAL INNER PACKAGE - LAND SERVICE)

FIG. 1

STENCILLED ON BOTH SIDES

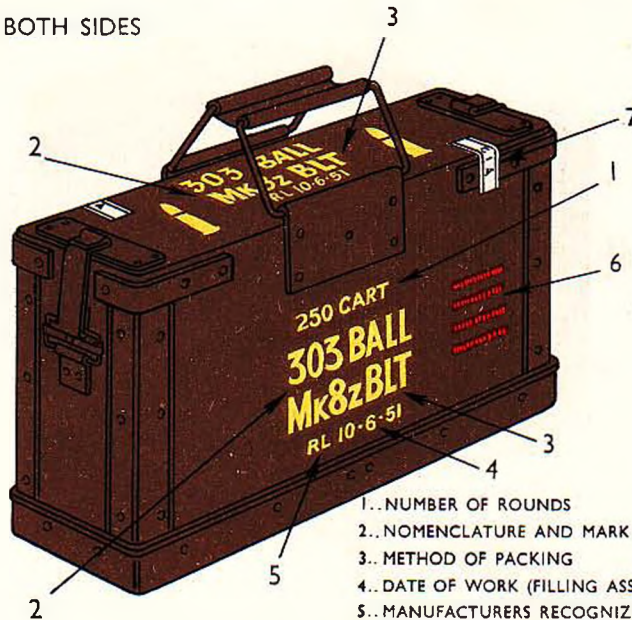

- 1.. NUMBER OF ROUNDS
- 2.. NOMENCLATURE AND MARK
- 3.. METHOD OF PACKING
- 4.. DATE OF WORK (FILLING ASSEMBLY)
- 5.. MANUFACTURERS RECOGNIZED MARK OR INITIALS
- 6.. RESTRICTED USE (WHEN APPLICABLE)
- 7.. INSPECTION SEALING LABELS

BOX A.S.A. H. 52 (TYPICAL INNER PACKAGE TINNED-PLATE BOX
LAND SERVICE)

FIG. 2

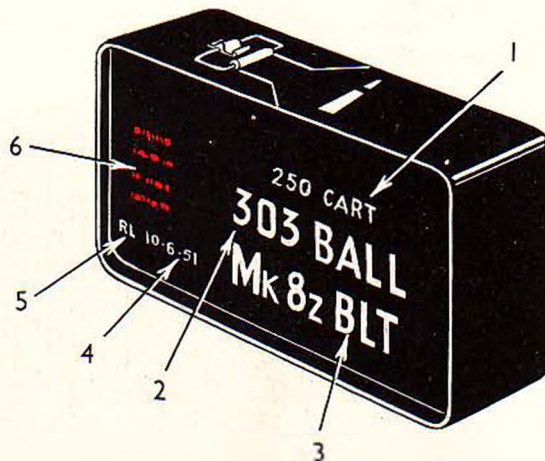

- 1.. NUMBER OF ROUNDS
- 2.. NOMENCLATURE AND MARK
- 3.. METHOD OF PACKING
- 4.. DATE OF WORK (FILLING ASSEMBLY)
- 5.. MANUFACTURERS RECOGNIZED MARK OR INITIALS
- 6.. RESTRICTED USE (WHEN APPLICABLE)

SECTION 5 (PART 2)

PLATE 4

BOX A.S.A. H. 47 (TYPICAL OUTER PACKAGE - AIR SERVICE)

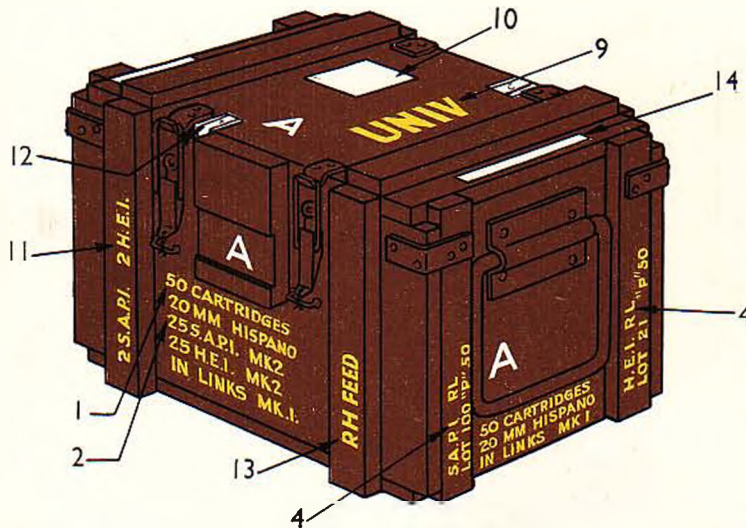

- 1.. NUMBER OF ROUNDS
- 2.. NOMENCLATURE AND MARK
- 3.. STORE REFERENCE NUMBER
- 4.. RECOGNIZED MARK OR INITIALS OF FILLER, AND LAST TWO FIGURES OF YEAR OF FILLING OF THE S.A.P.I. AND H.E.I. ROUNDS. THE LETTER "P" WHEN AMMUNITION CONTAINS FLASHLESS PROPELLANT
- 5.. RECOGNIZED MARK OR INITIALS OF THE BELTING UNIT OR CONTRACTOR'S BELTED LOT NUMBER AND LAST TWO FIGURES OF YEAR OF BELTING
- 6.. DATE OF PACKING AMMUNITION

- 7.. MANUFACTURER'S RECOGNIZED MARK OR INITIALS AND BATCH NUMBER OF LINKS
- 8.. "A" DENOTING CLASS A AMMUNITION
- 9.. TEMPERATURE AND CLIMATIC LIMITATIONS
- 10.. GOVERNMENT EXPLOSIVE GROUP (LABEL OR STENCIL)
- 11.. SEQUENCE OF ROUNDS IN BELT
- 12.. INSPECTION SEALING LABEL
- 13.. "L" OR "R" AS APPLICABLE
- 14.. TEMPERATURE LABEL

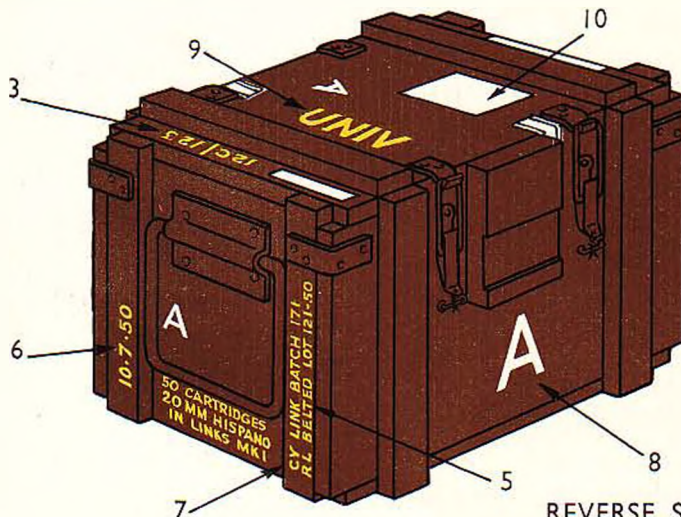

REVERSE SIDE AND END

BOX A.S.A. H. 54 (TYPICAL OUTER PACKAGE - AIR SERVICE)

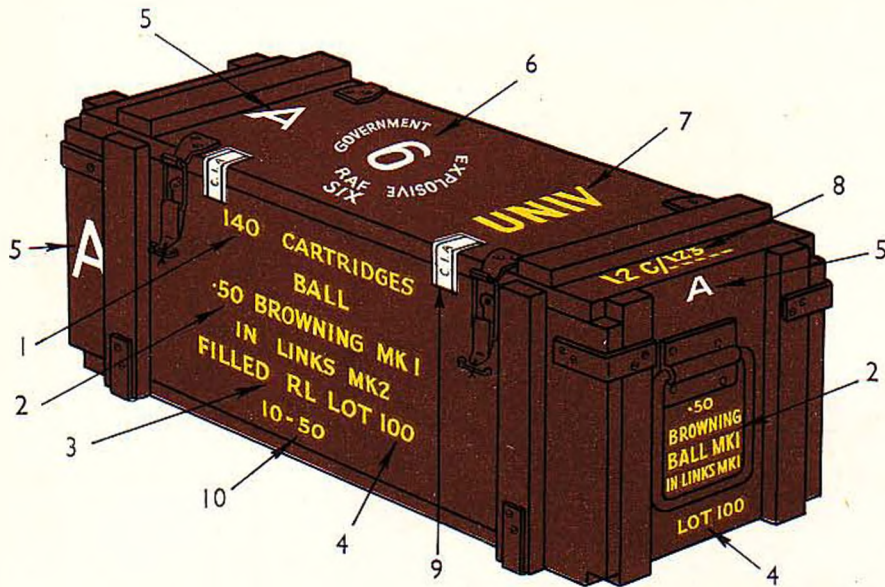

- 1.. NUMBER OF ROUNDS
- 2.. NOMENCLATURE AND MARK
- 3.. FILLERS RECOGNIZED MARK OR INITIALS
- 4.. FILLED LOT NUMBER
- 5.. "A" DENOTING CLASS A AMMUNITION

- 6.. GOVERNMENT EXPLOSIVE GROUP (LABEL OR STENCIL)
- 7.. TEMPERATURE AND CLIMATIC LIMITATIONS
- 8.. STORE REFERENCE NUMBER
- 9.. INSPECTION SEALING LABEL
- 10.. DATE OF FILLING (MONTH AND YEAR)

(RESTRICTED)

SECTION 5 (PART 2)
PLATE 6

BOX A.S.A. H. 60 (TYPICAL OUTER PACKAGE - AIR SERVICE)

- 1.. NUMBER OF ROUNDS
- 2.. CALIBRE
- 3.. NATURE AND MARK OF CARTRIDGE
- 4.. MARK OF LINKS (AS APPLICABLE)
- 5.. STORE REFERENCE NUMBER
- 6.. MANUFACTURER'S RECOGNIZED MARK OR INITIALS AND BATCH NUMBER OF LINKS
- 7.. RECOGNIZED MARK OR INITIALS OF BELTING UNIT OR MANUFACTURER'S BELTED LOT NUMBER AND YEAR OF BELTING (LAST TWO FIGURES)
- 8.. FILLERS RECOGNIZED MARK OR INITIALS
- 9.. LOT NUMBER AND YEAR OF MANUFACTURE (LAST TWO FIGURES)
- 10.. DATE OF PACKING (DAY, MONTH AND YEAR)
- 11.. "A" DENOTING CLASS A AMMUNITION
- 12.. TEMPERATURE AND CLIMATIC LIMITATIONS
- 13.. GOVERNMENT EXPLOSIVE GROUP (LABEL OR STENCIL)

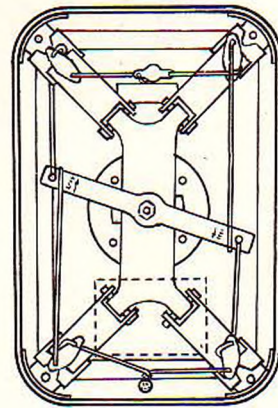
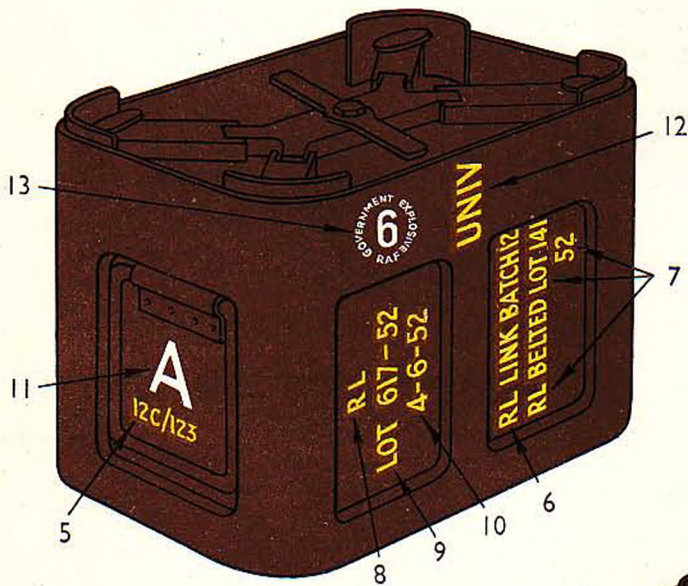

PLAN VIEW OF LID

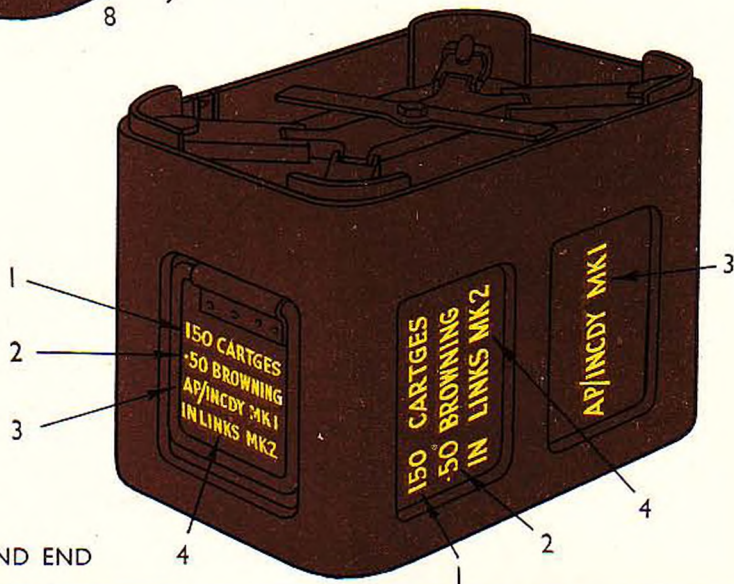

REVERSE SIDE AND END

RESTRICTED

W.O.
Code No.
1803

The information given in this document is not to be
communicated, either directly or indirectly, to the Press
or any person not authorised to receive it.

**INTER - SERVICE
AMMUNITION
AND
AMMUNITION PACKAGE
MARKINGS**

**SECTION 6 (Part 1)
SMALL ARMS AMMUNITION
(excluding 20 m.m. and 30 m.m.)
1952**

This Section, having been approved by the Lords Commissioners of the Admiralty, by the Army Council and by the Air Council, is promulgated for information and guidance.

By Command of their Lordships



By Command of the Army Council

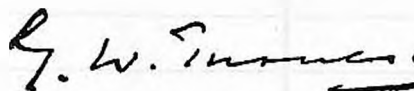

By Command of the Air Council

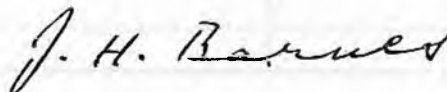

CONTENTS

Introduction—	Para.
Methods of Marking	1
Colour Markings	2
Stamping	3
Manufacturers' Code Letters	4
Cartridge Code Letters and Colours of Annulus	5
Propellant Code Letters	6

LIST OF PLATES

Typical—	Plate
·50-inch Ammunition (Air Service)	1
Small Arms Ammunition and Colouring of Annulus	2

INDEX

A

	Para.	Page
ANNULUS-COLOURS around cap	5.1	7
AP/Incendiary ·50-inch	5.1.1	7

B

Base marking	3.2	6
Blank—		
base markings	5.2.2.	7
colouring of bullets	2.1.1.	5
use of 2nd grade cases	5.2.2.	7
Bullets—colouring of	2.1.1.	5
Bullet tips—colouring of	2.1.2.	5

C

Cartridges for Grenades	2.2.4.	6
Cartridges for Smoke Generators	2.2.4.	6
Code Letters—		
on base of cases	5	7
for propellants	6	8
Colouring of—		
Annulus	5	7
Bullets	2.1.1.	5
Bullet tips	2.1.2.	5
Bullethead blank tips	2.1.1.	5
Cartridge cases	2.2.	6
Drill cartridges	2.2.2.	6
Inspection cartridges	2.2.3.	6
Proof cartridges	2.2.1.	6

INDEX—contd.

D

	Para.	Page
Drill cartridges	2.2.2.	6

G

Grenade cartridges	2.2.4.	6
---------------------------	--------	---

I

Incendiary .303-inch cartridges	2.1.2.	5
Identification—means of	1.2.	5
Inspection cartridges	2.2.3.	6
Inspection cartridges .50-inch	2.2.3	6

M

Manufacturers' code letters	4.1.	7
Methods of marking	1.1.	5

O

Observing .303-inch cartridges	2.1.2.	5
---------------------------------------	--------	---

P

Proof cartridges	2.2.1.	6
Propellant code letters	6	8

S

Smoke generator cartridges	2.2.4.	6
Stampings—		
on cartridge bases	3	6
of calibre	3.2.	6
of code letters	3.3.	6

T

Tracer—		
.22-inch R.F. ammunition	2.1.2.	5
.50-inch cartridges	2.1.2.	5

RESTRICTED

1. METHODS OF MARKING

1.1. The methods of marking described in this Section conform to those laid down in Section 1, General Introduction, which should be read in conjunction with it.

They consist of :—

Colour markings,
Stamping.

1.2. Small Arms Ammunition, with the exception of blank and .22-in. R.F., will normally be identified by one or more of the following means :—

Colour of bullet.
Colour of cartridge case.
Code letter or letters, stamped on the base of the case.
Colour of varnished annulus around the cap in the base.

2. COLOUR MARKINGS

2.1. Colour of bullet

2.1.1. In general, all bullets are left in their natural colour, except in the case of bulletted blank, when the whole bullet is coloured blue.

(Note.—Some existing stocks of old pattern bulletted blank have the bullet coloured yellow).

2.1.2. Certain natures of ammunition, designed primarily for Air Service use, and also .22-inch R.F. tracer ammunition, are identifiable by a coloured tip to the bullet. These are listed in the following table :—

Serial No.	Calibre	Nature	Colour and length of bullet tip	Remarks
1	.50-in.	AP/Incendiary	Silver, $\frac{5}{8}$ -in.	Conforms to markings of matched American round. Only means of identification; <i>see</i> also para. 5.2.1. below. Those of British manufacture have a narrow knurled cannellure immediately above the case/bullet joint.
2	.50-in.	Tracer	White, $\frac{5}{8}$ in.	Special night tracer now obsolete, had a grey tip.
3	.303-in.	Observing	Black, $\frac{3}{8}$ -in.	
4	.303-in.	Incendiary	Blue, $\frac{3}{8}$ -in.	B. Mk. 7 only.
5	.22-in. R.F.	Tracer	Red	Only means of identification.

2.2. Colour of cartridge case

This will be in the natural finish of the metal employed, except in the case of the following :—

- 2.2.1. Proof cartridges have the whole of the cartridge case copper-plated to render them instantly distinguishable. **This ammunition, which is intended solely for the high pressure testing of weapons, will not, under any circumstances, be used by the Services.** Although Proof ammunition will not normally be encountered the information concerning its markings is included to enable it to be recognized easily if ever found.
- 2.2.2. The cartridge cases of drill cartridges will :—
 - Be chromium plated,
 - Have three flutes, painted red,
 - Have the empty cap chamber painted red.
- 2.2.3. The cartridge cases of inspection cartridges will be chromium plated, and have the cap chamber left empty.
(*Note.*—·50-in. inspection cartridges will also have three equidistant holes, ·25-in. diameter, drilled in the wall of the case $1\frac{1}{2}$ inches from the base.)
- 2.2.4. Cartridges for discharging grenades or smoke generators, or for line throwing, will have no bullet, and will normally have the whole or part of the length of the cartridge case blackened. The mouth of the case may be closed by shellac covered cups or by crimping.
(*Note.*—Unbulleted blank may appear very similar, but the cartridge cases will be left entirely in their natural colour, and will be closed by crimping the mouth. *See* also para. 5.2.2. below.)
- 2.2.5. The base markings of cartridge cases, including the colour of the varnished annulus, are detailed in the tables in paras. 5 and 6.

3.

STAMPING

- 3.1. The following information is stamped on the base of each cartridge case :—
 - Contractor's initials or recognized mark.
 - Mark of cartridge (except ·22-in. R.F.).
 - Year of manufacture; last two figures only (except ·22-in. R.F.).
- 3.2. The calibre is also stamped on the base of all natures in the following calibres :—
 - 380-in., 9 mm., ·50-in.
- 3.3. In addition, the base markings of S.A.A. cartridge cases, except those of ball rounds, include a code letter, or letters, before the Mark to indicate the nature of the round; while all natures of round may bear a code letter after the Mark if a propellant other than Cordite is used. Details of all code letters are given in the relevant tables in paras. 5 and 6.
- 3.4. Where a particular cartridge possesses more than one characteristic, *e.g.*, A.P./Tracer, all the relevant code letters are stamped on the base, and the colour of the varnished annulus will be governed by the following order of precedence :—

Q, O, R, W, F, B, G, P.

(*e.g.*, A.P./Tracer, whose code letters are W and G respectively, will be stamped "WG" and have the annulus varnished Green).

4. MANUFACTURERS' CODE LETTERS

4.1. These consist of one or more letters indicating the filling factory. In the case of R.O.Fs. a broad arrow may be inserted between the letters.

5. CARTRIDGE CODE LETTERS AND COLOURS OF ANNULUS

5.1. The identification markings on the base of the cartridge case, which indicate the nature of the round, are as follows :—

Serial No.	Nature	Code Letter	Colour of Annulus	Remarks
1	Ball	Nil	Purple	
2	A.P.	W	Green	
3	Semi-A.P.	F	Green	
4	Tracer	G	Red	
5	Incendiary	B	Blue	
6	Proof	Q	Yellow	Special cartridge for the high pressure testing of weapons. NOT FOR SERVICE USE. See para. 5.2 <i>Exceptions</i> . May not bear code letter. Caps not ringed in.
7	Blank	L	Colourless	For drill purposes only. For armourers' use only.
8	Drill	D	} Empty Cap } Chamber	For training purposes. Gives visual indication on strike.
9	Inspection (formerly Dummy)	U		
10	Observing	O	Black	
11	Explosive	R	Black	
12	Rifle Grenade	H	Colourless	Caps not ringed in.
13	Smoke Discharger	E	Colourless	Caps not ringed in.
14	Practice	P	See "Remarks"	Not normally met in the Service, but may be introduced in an emergency. The annulus colour will be that of the parent type, e.g., Tracer/Practice, A.P./Practice etc.

5.2. *Exceptions*

5.2.1. The .50-in. Browning A.P./Incendiary cartridge (mentioned in para. 2.1) will have the cartridge code letter omitted from its base markings and bear a purple annulus.

5.2.2. Blank ammunition is an exception to the cartridge code letter markings laid down in the table above. Although blank assembled from 1st grade cases bears the correct code letter and mark on its base, blank may be made up from 2nd grade cases bearing the code letter and mark of any nature of bulletted ammunition. The latter can be distinguished from the nature whose markings it bears by the absence of both a coloured varnished annulus and ringing to retain the cap, as well as by the absence of a bullet.

6.**PROPELLANT CODE LETTERS**

6.1. The standard propellant for most Service S.A.A. at present is Cordite. Where a propellant other than Cordite is used a suffix letter is added to the base markings of the cartridge case after the number indicating the Mark.

6.2. Table of propellant code letters.

Serial No.	Code Letter	Type of Propellant
1	T	Black Powder.
2	Z	Any propellant other than Cordite or Black Powder, <i>e.g.</i> , Ballistite, Neonite etc.

.50-INCH AMMUNITION (AIR SERVICE)

FIG. 1

TYPICAL CARTRIDGE

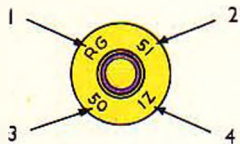

STAMPING

- 1.. CONTRACTORS RECOGNIZED MARK OR INITIALS
- 2.. YEAR OF MANUFACTURE
- 3.. CALIBRE
- 4.. MARK OF CARTRIDGE

FIG. 2

BALL



FIG. 3

AP/INCENDIARY



FIG. 4

TRACER

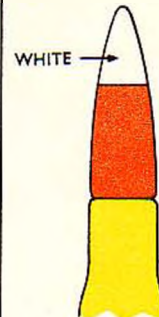

FIG. 5

DRILL

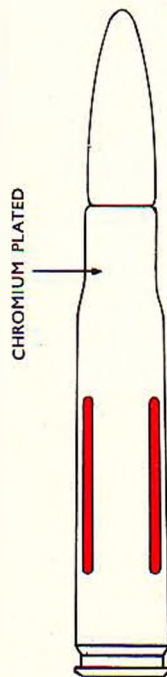
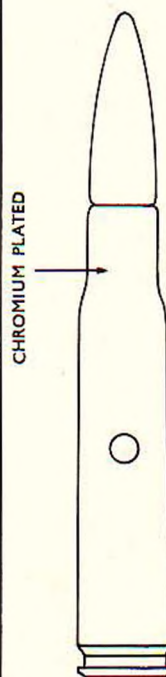













FIG. 6







INSPECTION



SMALL ARMS AMMUNITION

<p>FIG. 1</p> <p>RIMMED CASE .303"</p>   <p>BASE STAMPING (AS APPLICABLE)</p> <ol style="list-style-type: none"> CONTRACTORS RECOGNIZED MARK OR INITIALS YEAR OF MANUFACTURE MARK 	<p>FIG. 2</p> <p>RIMLESS CASE 7-92 mm</p>   <p>BASE STAMPING (AS APPLICABLE)</p> <ol style="list-style-type: none"> CONTRACTORS RECOGNIZED MARK OR INITIALS YEAR OF MANUFACTURE MARK 	<p>FIG. 3</p> <p>RIMMED CASE .380"</p>   <p>BASE STAMPING</p> <ol style="list-style-type: none"> CONTRACTORS RECOGNIZED MARK OR INITIALS YEAR OF MANUFACTURE MARK CALIBRE 	<p>FIG. 5</p> <p>RIM FIRE .22" BALL</p>  
		<p>FIG. 4</p> <p>RIMLESS CASE 9 mm</p>   <p>BASE STAMPING</p> <ol style="list-style-type: none"> CONTRACTORS RECOGNIZED MARK OR INITIALS YEAR OF MANUFACTURE MARK CALIBRE 	<p>FIG. 6</p> <p>RIM FIRE .22" TRACER</p>  

COLOUR OF ANNULUS

<p>FIG. 7</p> <p>BALL</p> 	<p>FIG. 8</p> <p>A.P.</p> 	<p>FIG. 9</p> <p>TRACER</p> 	<p>FIG. 10</p> <p>INCENDIARY</p> 
<p>FIG. 11</p> <p>BLANK (1st GRADE CASES)</p> 	<p>FIG. 12</p> <p>BLANK (2nd GRADE CASES TYPICAL)</p> 	<p>FIG. 13</p> <p>OBSERVING</p> 	

RESTRICTED

W.O.
Code No.
1803

The information given in this document is not to be communicated, either directly or indirectly, to the Press or to any person not authorized to receive it.

INTER - SERVICE
AMMUNITION
AND
AMMUNITION PACKAGE
MARKINGS

SECTION 6 (Part 3)
GRENADES
1952

This Section, having been approved by the Lords Commissioners of the Admiralty, by the Army Council and by the Air Council, is promulgated for information and guidance.

By Command of their Lordships,

J. S. Lang

By Command of the Army Council,

G. W. Turner

By Command of the Air Council,

J. H. Barnes

CONTENTS

Introduction—	Para.
1. Methods of marking	1
2. Colour markings	2
3. Stencilling	3
4. Stamping or Embossing	4
5. Exceptions	5

LIST OF PLATES

	Plate
Grenade, Hand, No. 36M H.E.	1 Fig. 1
Grenade, Hand, No. 80 W.P.	1 Fig. 2
Grenades, Hand, No. 83 Smoke (Coloured)	1 Fig. 3
Grenade, Hand, Chemical (Typical)	1 Fig. 4
Grenade, Hand, Drill, No. 75	1 Fig. 5

INDEX

	Para.	Page
Basic body colours	2.1	4
Chemical grenades	2.3.1	4
Colour markings	{ 1.0	4
	{ 2.0	4
Colour rings	2.2	4
Colour rings special feature	2.3	4
Embossing	3.2	5
	4.0	5
Foreign grenades—markings	5.0	5
Grenades—foreign, marking of	5.0	5
Grenades—smoke	{ 2.1	4
	{ 3.1	5
H.E. grenades	2.1	4
H.E. grenades filled T.N.T.	Plate 1	Fig. 1
	Para.	Page
Methods of marking	1.0	4
Practice grenades	2.3.2.	4
Red filling rings	2.2	4
Red filling rings position of	2.2.1	4
Stamping or embossing	4.0	5
Stencilling	1.0	4
	3.0	5
Tactical Nature Markings	2.3.1	5

RESTRICTED

1. METHODS OF MARKING

The methods of marking in this section conform to those laid down in Section I, General Introduction, which should be read in conjunction with it.

They consist of the following :—

- Colour markings
- Stencilling
- Stamping or Embossing

2. COLOUR MARKINGS

2.1 *Basic body colours* follow the general system as for projectiles (Section 2) and consist of the following :—

Colour	Title	Remarks
Buff	High Explosive	As an exception certain grenades with cast iron bodies may be varnished in their natural colour instead of buff to indicate H.E.
Light Green	Smoke	
Grey	Chemical	
Red Oxide	Incendiary	
White	Practice or Drill	

2.2 A *red filling ring* is painted over the basic body colour to denote that the store contains an active agent and is normally classified for storage in an Explosives Group.

2.2.1 *The position of the red filling ring* will depend on the nature of the store, and is usually painted around the grenade near the top and above the stencilling.

A *plain red ring* indicates suitability for issue and storage under all conditions.

A *cross-bar-cross red ring* indicates a limited life in hot climates.

A *hatched red ring* denotes restriction of issue and storage to temperate climates only.

2.3 *Special feature coloured rings* may be painted over the basic body colour to indicate special features.

2.3.1 *Chemical grenades* have the basic body colour grey and the tactical nature of the chemical agent is indicated as follows :—

Green ring(s) and green code lettering indicate a casualty-producing agent.

Red-ring(s) and red code lettering indicate a harassing agent.

One coloured ring indicates a non-persistent agent.

Two coloured rings indicate a persistent agent.

2.3.2 *Practice grenades* are identified by a yellow band painted over the basic body colour and around the centre of the grenade.

RESTRICTED

3. STENCILLING

- 3.1 Stencilling is applied over the basic body colour, on the coloured rings, or both, to make identification complete. Where size and shape of store permit the following information is normally stencilled on the grenade :—

Nomenclature (in abbreviated form) and Mark.

Date of filling (month and year).

Colour of smoke (in the case of coloured smoke grenades) *e.g.* RED, GREEN, BLUE or YELLOW, the lettering being in white.

Initials or recognized mark of charging station and date of charging (month and year), in the case of chemical stores only.

Nature of filling, smoke composition or chemical charging, as applicable.

Instructions for use may also be given on some grenades.

- 3.2 Where the size or shape of the grenade does not permit of the stencilling referred to in para. 3.1 either all or part of the information required will be stamped or embossed on a convenient surface.

4. STAMPING OR EMBOSSING

- 4.1 *Stamping or embossing* is used to indicate details of empty manufacture for inspection purposes and is not normally required by the user except for that referred to in para. 3.2. The following information in the form of stamping or embossing may therefore be found on grenades :—

Identification and mark of empty store.

Recognized mark or initials of the manufacturer of the empty store.

Lot number or date of manufacture of the empty store.

5. EXCEPTIONS

Grenades of Foreign Origin.

In certain cases, where grenades of foreign origin are adopted in the British Service, a foreign system of colour marking may be accepted in order to conform to the requirements of one or more of our allies.

In such cases details of the method of marking adopted will be promulgated by the Service concerned.

GRENADES

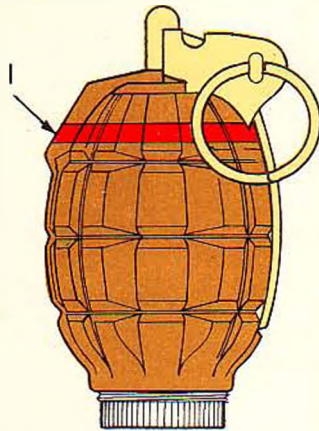
FIG. 1.
GRENADE, HAND No. 36M, H.E.

1 . . RED FILLING RING

NOTE.

IF FILLED TNT THE LETTERS
TNT WILL BE STENCILLED ON
THE BODY IN LIGHT CONTRASTING
COLOUR PAINT.

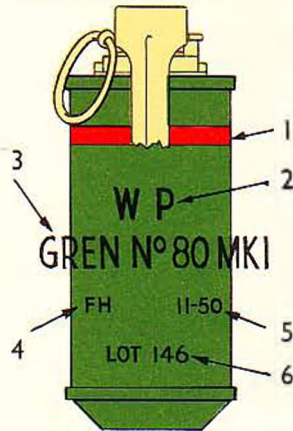
FIG. 2.
GRENADE, HAND, No. 80 W.P.

- 1 . . RED FILLING RING
- 2 . . NATURE OF FILLING
- 3 . . NOMENCLATURE AND MARK
- 4 . . RECOGNIZED MARK OR INITIALS OF CHARGING STATION
- 5 . . DATE OF CHARGING (MONTH AND YEAR)
- 6 . . FILLED LOT NUMBER

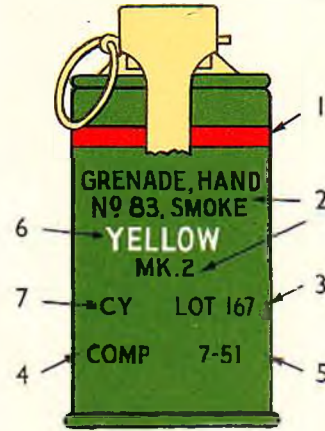
FIG. 3. GRENADE, HAND,
No. 83 SMOKE (COLOURED)

- 1 . . RED FILLING RING
- 2 . . NOMENCLATURE AND MARK
- 3 . . FILLED LOT NUMBER
- 4 . . COMPOSITION CODE
- 5 . . DATE OF FILLING
- 6 . . COLOUR OF SMOKE (AS APPLICABLE)
- 7 . . RECOGNIZED MARK OR INITIALS OF FILLER

FIG. 4. GRENADE, HAND, CHEMICAL (TYPICAL)

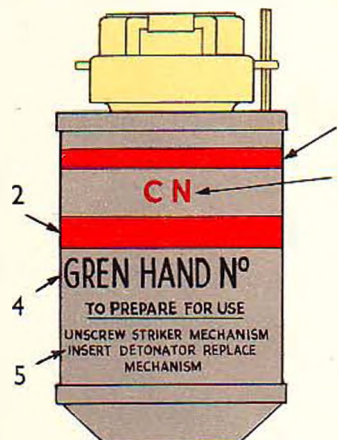

- 1 . . RED FILLING RING
- 2 . . TYPE OF CHARGING (TACTICAL USE)
- 3 . . CODE OF CHARGING
- 4 . . NOMENCLATURE AND MARK
- 5 . . INSTRUCTIONS FOR USE
- 6 . . RECOGNIZED MARK OR INITIALS OF FILLER
- 7 . . FILLED LOT NUMBER

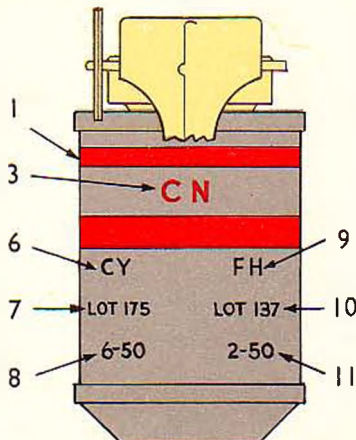

- 8 . . DATE OF FILLING (MONTH AND YEAR)
- 9 . . CHARGING DETAILS
- 10 . . RECOGNIZED MARK OR INITIALS OF CHARGING STATION
- 11 . . FILLED LOT NUMBER
- 11 . . DATE OF CHARGING (MONTH AND YEAR)

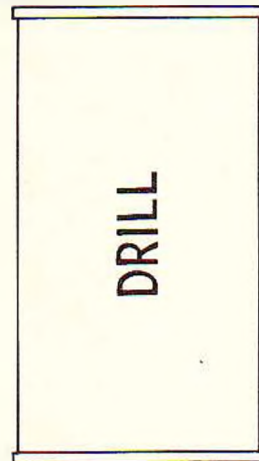
FIG. 5.
GRENADE, HAND, DRILL No 75

RESTRICTED

The information given in this document is not to be
communicated, either directly or indirectly, to the
Press or to any person not authorized to receive it

W.O.
CODE NO.
1803

**INTER-SERVICE
AMMUNITION AND
AMMUNITION PACKAGE
MARKINGS**

SECTION 7

MISCELLANEOUS

(Including Underwater Weapons, Land Service Mines and Fuzes,
Demolition Charges, Switches and Detonators)

1953

This Section, having been approved by the Lords Commissioners of the Admiralty, by the Army Council and by the Air Council, is promulgated for information and guidance.

By Command of their Lordships

J. G. Lang

By Command of the Army Council

G. W. Turner

By Command of the Air Council

J. H. Barwell

CONTENTS

Introduction—		Para.
Methods of marking		1
List of stores		2
Classification of stores		3
Markings and stencilling		4

LIST OF PLATES

		Plate
Warhead, torpedo } Depth charges } Mines } Mines, exercise }	Naval Service	1
Projectile, Hedgehog } Projectile, A.S. Practice, Hedgehog } Projectile A.S. Naval Service ..	Naval Service	2
Device, rope cutting		3
Mine, Anti-Personnel, No. 6, Mk. 1 ..		4
Mine, Anti-Tank, Mk. 7		4
Fuze, Mine, Anti-Tank, No. 4		5
Switch, Pull, No. 4, Mk. 1		5
Snout, Switch, Capped, Mk. 1		6
Switch, Time Pencil, No. 10, Mk. 1 ..		7
		7
		7

INDEX

A

		Para.		Page
Anti-personnel fuzes		{ 2.2		6
		{ 3.5		7
		{ 4.5		8
Anti-personnel mines		2.2		6
		{ 2.2		6
Anti-tank fuzes		{ 3.5		7
		{ 4.5		8
Anti-tank mines		2.2		6

B

Basic body colours.. .. .		1-1		6
---------------------------	--	-----	--	---

C

Cased charges		3.1		6
Cased intermediaries		{ 3.3		6
		{ 4.3		8
CE/TNT Slabs		4.2.1		8
Charges demolition		2.1		6
Charges for explosive sweep		2.1		6
Classification of stores		3.0		6
Colours—basic body		1.1		6
Colour Code. Naval stores		4.1.5		7
Colour—rings or strips		1.1		6
		{ 3.8		7
Cord fuzes		4.8		9

INDEX—contd.

D										Para.	Page
Delay switches	4.7.2	9
Demolition detonators	2.3	6
Demolition stores	2.1	6
Depth charges	2.1	6
Detonators	2.1	6
Devices, rope cutting	2.1	6
Drill cordtex	4.8	9
Drill stores—Land Service	4.19.	8
Drill stores—Naval Service	2.3	6
Dummy stores—Land Service	4.1.6	7
E											
Embossing	1.1	6
Explosive mine—breaching devices	2.2	6
Explosives—Gelignite	} 4.2.2	8
Explosives—Plastic		
F											
Fuzes, mines anti-personnel	2.2	6
Fuzes, mines anti-personnel	3.5	7
Fuzes, mines anti-tank	4.5	8
G											
Gelignite	4.2.2	8
Guncotton slabs	} 4.2.3	8
Guncotton slabs drill		
I											
Initiators—caps, detonators, etc...	} 3.6	7
		
Initiatory mechanisms	} 3.7	7
		
Instructional stores...	4.1.8	8
L											
Labels	1.1	6
Lists of stores	2	6
M											
Markings and stencillings	4	7
Markings and stencillings, cased charges	4.1	7
Mines, anti-personnel	2.2	6
Mines, anti-tank	2.2	6
Mines and mine charge cases	2.1	6

INDEX—contd.

N

	Para.	Page
Naval markings	4.1.5	7

P

Plastic explosives	4.2.2	8
Practice stores	4.1.7	8
Primer for warheads, mines and depth charges..	2.1	6
Printed labels	1.1	6
Projectiles, Hedgehog and A.S.	2.1	6

R

Rings—coloured	{ 1.1 4.1.5	6 7
------------------------	----------------	--------

S

Stampings	{ 1.1 4.1.4	6 7
Shaped charge	3.0	6
Stencilling	{ 1.1 4.1.3	6 7
Stores—classification of	3.0	6
Switches and mechanisms..	{ 2.2 4.7.1	6 9

T

“T” Cutters	2.1	6
Transfers	1.1	6

U

Uncased charges	{ 3.2 4.2	6 8
Uncased Intermediaries	{ 3.4 4.4	7 8
Under-water stores—colour code	4.1.5	7

W

Warheads, Torpedo	2.1	6
---------------------------	-----	---

RESTRICTED

INTRODUCTION

1. METHODS OF MARKING

The methods of marking in this section conform to those laid down in Section I, General Introduction which should be read in conjunction with it.

1.1. *Markings used*

Owing to the diverse nature of the stores dealt with in this section, it is not possible to lay down any hard and fast system of marking. The following methods will, however, be employed as circumstances permit:—

- Basic body colours.
- Coloured rings or strips.
- Stencilling or transfers.
- Stamping or embossing.
- Labels or printed wrappers.

2. LIST OF STORES

The following stores are included in this section:—

2.1. *Naval Service*

- Warheads torpedo.
- Mines and mine charge cases.
- Depth charges.
- Projectiles, Hedgehog and A.S.
- Charges demolition.
- Devices rope cutting.
- Charges for explosive sweep.
- Primers for warheads, mines and depth charges.
- "T" cutters.
- Detonators.

2.2. *Land Service*

- Mines and fuzes, A./tk., A./personnel, beach and fluvial.
- Explosive mine—Breaching devices.
- Miscellaneous demolition stores.
- Shaped charges.
- Switches and mechanisms.

2.3. *Air Service*

- Demolition detonators, destructors and other relevant stores referred to above in Naval and Land Services.

3. CLASSIFICATION OF STORES

Although rigid classification of all stores in this section is difficult, or impossible, the majority of them can nevertheless be grouped as follows:—

- 3.1. *Cased charges*: including warheads, mines and depth charges, anti-tank mines, Clams, Limpets, and shaped charges such as Beehives, Hayricks, etc.
- 3.2. *Uncased charges*: e.g., wet guncotton slabs, CE/TNT slabs, and wrapped cartridges such as gelignite, Nobel's 808.
- 3.3. *Cased intermediaries*: e.g., primers warhead, detonator-bursters (other than for aircraft bombs).

- 3.4. *Uncased intermediaries: e.g., dry guncotton primers, CE primers.*
- 3.5. *Fuzes, Mines A./tk. and A./Personnel.*
- 3.6. *Initiators: e.g., caps, detonators.*
- 3.7. *Initiatory mechanisms: e.g., igniters, switches, delay mechanisms.*
- 3.8. *Cord fuzes: e.g., time fuze, instantaneous fuze, detonating cord.*

4. MARKINGS AND STENCILLING

4.1. *Cased charges*

These charges will normally be marked as follows:—

- 4.1.1. *Basic body colour*, as determined by the user Service to meet the requirements of camouflage, for ease of recovery (in practice or drill), for preservation or for differentiation of the store.
- 4.1.2. *Red filling symbol* consisting of a Red ring, band or strip, denoting that the store contains an active agent and is normally classified for storage in an Explosives Group. It will be applied in a prominent position which will be determined by the shape of the store and the user requirements.
- 4.1.3. *Stencilling*, applied in a contrasting colour, to include the following details:—
 - Nomenclature and mark of store.
 - Code denoting nature of main explosive filling (Sec. 2, pages 19-22).
 - Filler's initials or recognized mark.
 - Date of filling (month and year).
 - Filled lot number.
- 4.1.4. *Stamping, moulding or embossing*, to denote particulars of manufacture of the empty store. The initials or recognized mark of the maker of the empty store, and the date of manufacture (month and year) are normally shown. Other markings may also be employed on certain stores.
- 4.1.5. *In Naval and Air Services* the type of filling for under-water stores is indicated by a colour code in addition to stencilling.

Details are as follows:—

- Plain Light Green ring*, to indicate TNT, or a low grade Amatol filling (*i.e.*, one containing a grade of TNT below Grade 1).
- Light Green criss-cross ring*, to indicate a high grade Amatol filling (*i.e.*, one containing TNT, Grade 1).
- Ring of Light Blue discs*, to indicate a Torpex filling.
- Ring of Light Green discs*, to indicate a Minol filling.
- Black ring*, to indicate an inert-filled charge for explosive sweep.
- Yellow ring*, indicates an exercise mine part-filled inert mixture and part-filled sodium phosphide.
- Plain Blue ring*, indicates RDX/TNT filling.

4.1.6. *Drill, etc.*—Stores will be indicated as follows:—

In *Naval Service* inert-filled stores which may be used for drill purposes are painted according to the requirements of the Service but are prominently stencilled "INERT".

In *Land Service* drill or dummy cased charges will be painted White and stencilled "DRILL" or "DUMMY" (as applicable) in large Black type. The word "DRILL" or "DUMMY", however, should always be present irrespective of the basic body colour adopted.

In *Air Service* drill stores of Naval or Land Service origin will be marked in accordance with the policy of the parent Service.

- 4.1.7. *Practice stores* will, where possible, be painted Black and identified by a Yellow band.

The Yellow band, however, will always be present irrespective of what basic body colour is adopted.

Note.—If a fuze containing an active agent is used in conjunction with an inert filled practice mine, and if on assembly this item is not readily visible, a Red ring will be affixed or painted on or a suitable warning tab or label attached to the main store. Care must be taken, however, to remove this Red ring, tab or label should the main store be subsequently dismantled.

- 4.1.8. *Instructional stores.*—These normally consist of the complete assembled store but contain *no* explosive or pyrotechnic composition. The body will be painted the approved Service colour; the Red ring indicating that a store contains an active agent will be omitted. The word "EMPTY" will be stencilled on the body in light contrasting colour paint.
- 4.1.9. *Stores with transparent plastic casing* may have their details and Red filling ring shown on a label applied to the inside surface of the case. Stores with plastic cases (*e.g.*, Clams) are often difficult to paint. They are normally left in their natural colour and stencilling is replaced by transfers where necessary.

4.2 *Uncased charges*

These can be sub-divided as follows:—

- 4.2.1. *Charges enclosed in cartons*, such as CE/TNT slabs. These have the information detailed in para. 4.1.3. printed on the carton. Drill stores made from inert material will be prominently stencilled with the word "DRILL" in Black type.
- 4.2.2. *Charges wrapped in paper*, such as cartridges of gelignite, Nobel's 808 and 852, plastic explosive. These are usually trade stores and sufficient information for identification will normally be printed on the paper wrapping, although the markings may not conform to Service markings.
- 4.2.3. *Charges without any wrapping*, such as wet guncotton slabs. These charges will not normally bear any markings, all necessary details being found on the package. Drill stores will be made of wood, left in natural colour and stencilled prominently with the word "DRILL" in Black type.

4.3. *Cased Intermediaries*

These will bear a Red filling symbol as indicated in para. 4.1.2. Where size permits the information shown in para. 4.1.3. (with the exception of code denoting nature of main explosive filling) will be stencilled on the store. Where size of the store is too small to permit of stencilling this information will be stamped, embossed or rolled on the body. Drill stores will be painted White.

4.4. *Uncased intermediaries*

These will be treated as in paras. 4.2.2. and 4.2.3.

4.5. *Fuzes A./tk. and A./Pers. (see Plate 6)*

They will not normally be painted or stencilled but will be stamped with the store number and mark, the maker's initials or recognized trade mark, lot or batch number and year of manufacture. The filled lot number, the filler's initials or recognized monogram and date (month and year) of filling or assembly will also be stamped or shown on a label affixed to the store (*see* para. 4.1.4. above).

Fuzes for Mines A./tk. Mark 7 are normally issued in the mines, the fuzes being placed base uppermost so that the legend "MINE UNARMED" on the base is visible when the cover is removed.

Fuzes for Mines A./tk. Mark 5 HC are always packed separately and must be assembled to the mine immediately before laying.

Fuzes for Mines, A./Personnel, etc., are normally issued packed separately but in the same box as the mines.

4.6. *Initiators*

Stencilling or stamping of caps, detonators, etc., is normally impracticable owing to the small size of these stores. The necessary information will therefore be found on the package.

4.7. *Initiatory mechanisms*

4.7.1. *Switches, igniters, etc.*, will not normally be painted or stencilled, but will be stamped with the nomenclature and mark, the maker's initials or recognized mark, and date of manufacture (month and year). Explosive components, such as capped snouts, will be distinguished by a Red ring or annulus.

4.7.2. *Delay switches* will normally be marked with patches of colour to indicate time of delay. These colours will be decided by the user Service.

4.8. *Cord fuzes*

Normally it is impracticable to identify such stores by stencilling, stamping, etc., although in the case of drill (or dummy) cordtex it will be identifiable as follows:—

4.8.1. Earlier issues will have a plain or semi-transparent White cover with an interwoven Red thread. This cover will be marked at foot intervals, with the word "DRILL" in bright Red.

4.2.8. Later issues will be distinguished by a longitudinal ridge on the surface of the cover. The ridge will extend along the entire length of the cordtex. The cover will *not* be marked "DRILL" but the cordtex will be wound on Brown painted reels (in Cylinder No. 443 and Box 340) stencilled with the word "DRILL" (or "DUMMY").

The ridge method of marking provides identification by touch as well as by sight, giving positive identification under conditions of difficult visibility.

Note.—Owing to the great variety of stores dealt with in this section, no comprehensive set of coloured illustrations is possible within the scope of this publication. A number of typical examples are, however, illustrated in Plates 1 to 7.

MISCELLANEOUS (NAVAL SERVICE)

FIG. 1

WARHEAD, TORPEDO

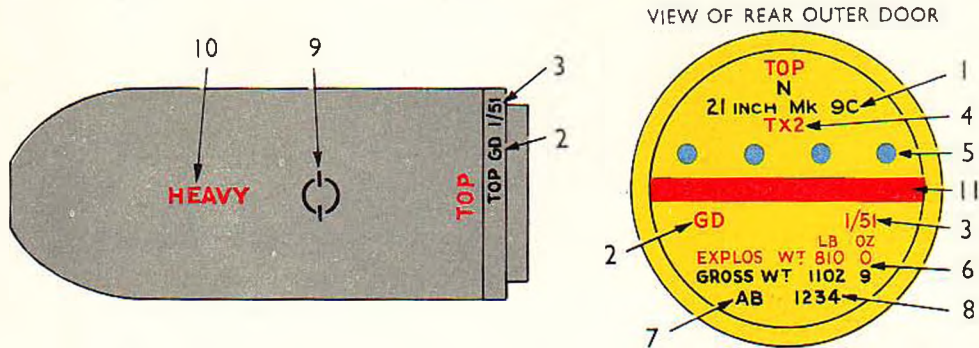

- | | |
|--|--|
| 1..... SIZE AND MARK (INCLUDING TYPE LETTER) | 8..... REGISTER NUMBER |
| 2..... FILLERS RECOGNIZED MARK OR INITIALS | 9..... CENTRE OF GRAVITY SYMBOL (IN THREE PLACES AROUND WARHEAD) |
| 3..... DATE OF FILLING (MONTH AND YEAR) | 10..... "HEAVY" INDICATING THAT WARHEAD IS HEAVIER THAN THE ONE TIME STANDARD TNT FILLED ITEM (ON TOP AND SIDES) |
| 4..... FILLING CODE LETTERS | 11..... RED FILLING BAND |
| 5..... COLOUR CODE DENOTING TYPE OF FILLING | |
| 6..... WEIGHT DETAILS | |
| 7..... CONTRACTORS RECOGNIZED MARK OR INITIALS | |

FIG. 2

DEPTH CHARGES

SIMILAR MARKINGS BUT WITHOUT THE TALLY PLATE AND SERIAL NUMBER WILL BE FOUND ON THE OTHER END OF THE DEPTH CHARGE

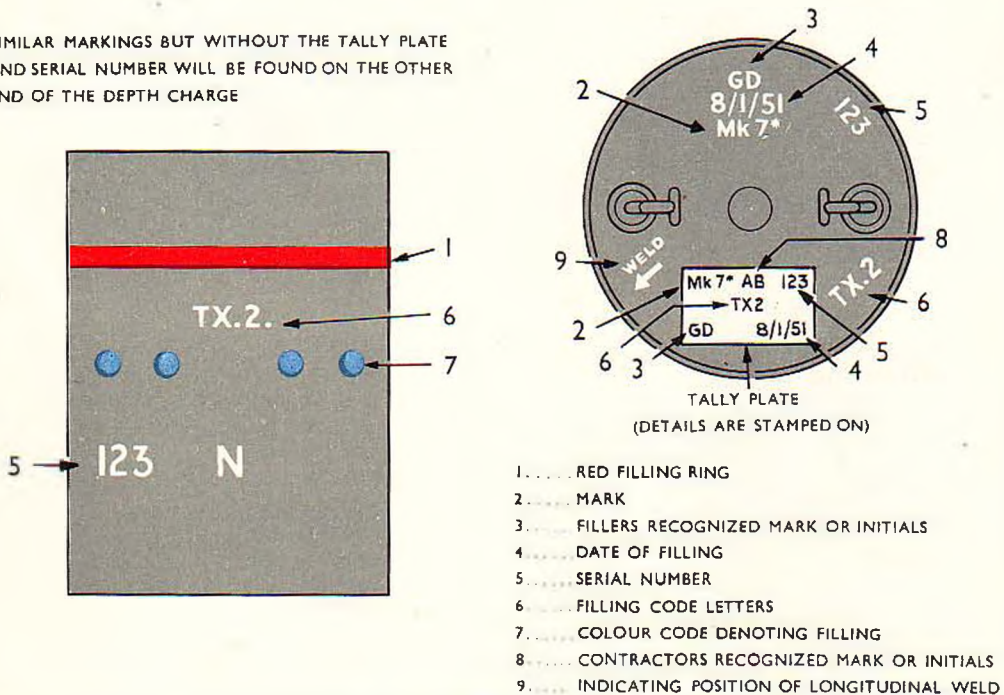

MISCELLANEOUS (NAVAL SERVICE)

FIG. 1

MINES

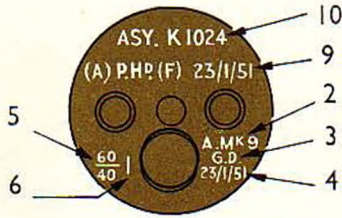

VIEW ON FRONT PLATE

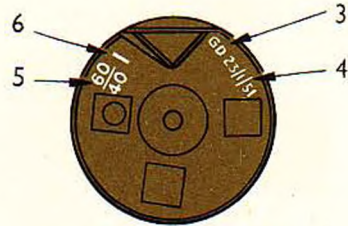

VIEW ON REAR BULKHEAD

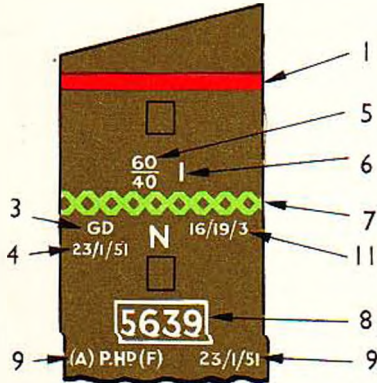

- 1..... RED FILLING RING
- 2..... TYPE OR MARK
- 3..... FILLERS RECOGNIZED MARK OR INITIALS
- 4..... DATE OF FILLING
- 5..... FILLING CODE (PROPORTION)
- 6..... GRADE OF T.N.T USED IN AMATOL FILLING
- 7..... COLOUR CODE DENOTING FILLING
- 8..... DEPOT SERIAL NUMBER
- 9..... ASSEMBLY STATION AND DETAILS OF ASSEMBLY
- 10..... ASSEMBLY NUMBER.
- 11..... CONTRACTORS RECOGNIZED MARK OR INITIALS

FIG. 2

MINES EXERCISE



VIEW ON FRONT PLATE



VIEW ON REAR BULKHEAD

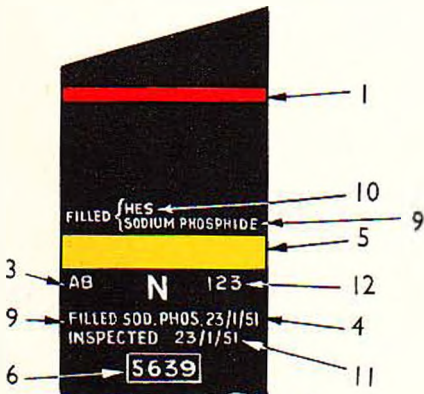

- 1..... RED FILLING RING
- 2..... TYPE
- 3..... FILLERS RECOGNIZED MARK OR INITIALS (APPLIES ONLY TO SOD. PHOS. FILLING)
- 4..... DATE OF FILLING
- 5..... YELLOW BAND DENOTING EXERCISE (PRACTICE)
- 6..... DEPOT SERIAL No
- 7..... ASSEMBLY STATION
- 8..... ASSEMBLY NUMBER
- 9..... NATURE OF WATER ACTIVATED FILLING
- 10..... NATURE OF INERT FILLING
- 11..... INSPECTION DETAILS
- 12..... D.A.S. ORDER No. FOR INERT FILLING

MISCELLANEOUS (NAVAL SERVICE)

FIG. 1

PROJECTILE HEDGEHOG

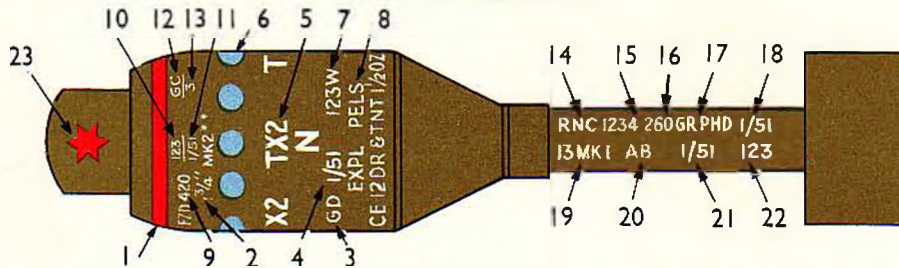

- 1. RED FILLING RING
- 2. SIZE AND MARK
- 3. FILLERS RECOGNIZED MARK OR INITIALS
- 4. DATE OF FILLING (MONTH AND YEAR)
- 5. FILLING CODE LETTERS
- 6. COLOUR CODE DENOTING TYPE OF FILLING
- 7. LOT NUMBER (EMPTY AND FILLED) WITH CODE LETTER DENOTING MAKER
- 8. EXPLODER DETAILS
- 9. SERIAL NUMBER
- 10. FILLED LOT NUMBER
- 11. CONTRACTORS RECOGNIZED MARK OR INITIALS
- 12. DATE OF FILLING (MONTH AND YEAR)
- 13. MARK

- CARTRIDGE PARTICULARS
- 14. DISTINGUISHING LETTERS OF PROPELLANT MANUFACTURER
 - 15. LOT NUMBER OF PROPELLANT
 - 16. WEIGHT OF CHARGE (IN GRAINS)
 - 17. FILLERS RECOGNIZED MARK OR INITIALS
 - 18. DATE OF FILLING (MONTH AND YEAR)
- PRIMER PARTICULARS
- 19. NUMBER AND MARK
 - 20. FILLERS RECOGNIZED MARK OR INITIALS
 - 21. DATE OF FILLING (MONTH AND YEAR)
 - 22. LOT NUMBER
23. DENOTES THAT PROJECTILE IS FUZED

FIG. 2

PROJECTILE A/S, PRACTICE HEDGEHOG

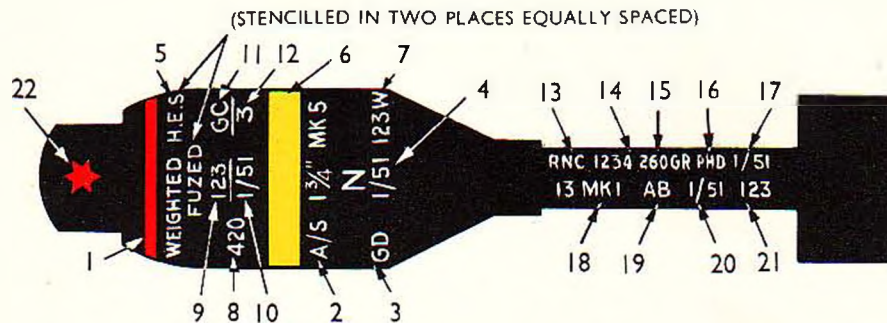

- 1. RED FILLING RING
- 2. SIZE AND MARK
- 3. FILLERS RECOGNIZED MARK OR INITIALS
- 4. DATE OF FILLING
- 5. FILLING DETAILS
- 6. YELLOW BAND DENOTING PRACTICE
- 7. LOT No. (EMPTY AND FILLED) WITH CODE LETTER DENOTING MAKER
- 8. SERIAL NUMBER
- 9. FILLED LOT NUMBER
- 10. DATE OF FILLING
- 11. MAKERS RECOGNIZED MARK OR INITIALS
- 12. MARK

- CARTRIDGE PARTICULARS
- 13. DISTINGUISHING LETTERS OF PROPELLANT
 - 14. LOT No OF PROPELLANT
 - 15. WEIGHT OF CHARGE (IN GRAINS)
 - 16. FILLERS RECOGNIZED MARK OR INITIALS
 - 17. DATE OF FILLING (MONTH AND YEAR)
- PRIMER PARTICULARS
- 18. NUMBER AND MARK
 - 19. FILLERS RECOGNIZED MARK OR INITIALS
 - 20. DATE OF FILLING
 - 21. LOT NUMBER
22. DENOTES THAT PROJECTILE IS FUZED

SECTION 7
PLATE 4

MISCELLANEOUS (NAVAL SERVICE)

FIG. 1

PROJECTILE, A.S.

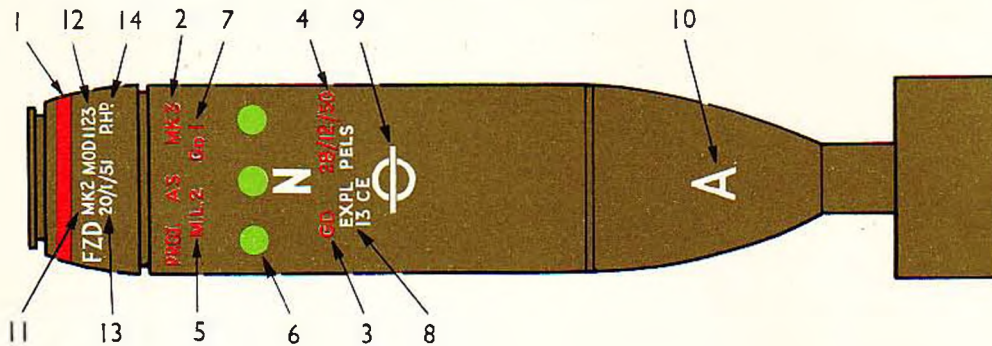

- 1. RED FILLING RING
- 2. NOMENCLATURE AND MARK
- 3. FILLERS RECOGNIZED MARK OR INITIALS
- 4. DATE OF FILLING
- 5. FILLING CODE LETTERS
- 6. COLOUR CODE DENOTING TYPE OF FILLING
- 7. GRADE OF T.N.T. USED IN MINOL FILLING
- 8. EXPLODER DETAILS

- 9. CENTRE OF GRAVITY SYMBOL (IN THREE PLACES EQUALLY SPACED AROUND BODY)
- 10. "A" DENOTES THAT THE TAIL CONE HAS BEEN ANNEALED

FUZE PARTICULARS

- 11. MARK AND MOD. NUMBER
- 12. LOT NUMBER
- 13. DATE OF FUZING PROJECTILE
- 14. CONTRACTORS RECOGNIZED MARK OR INITIALS

FIG. 2

DEVICE, ROPE CUTTING.

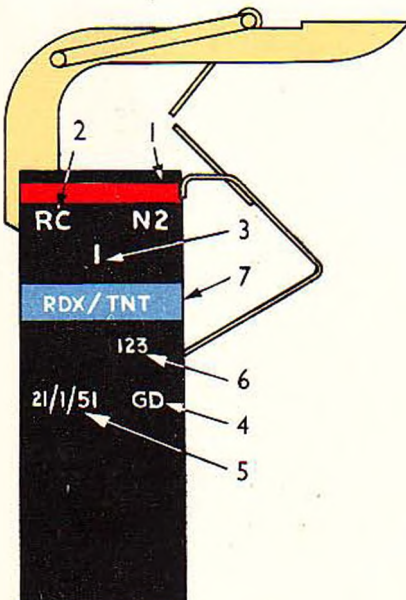

- 1. RED FILLING RING
- 2. NOMENCLATURE
- 3. MARK
- 4. FILLERS RECOGNIZED MARK OR INITIALS
- 5. DATE OF FILLING
- 6. SERIAL NUMBER
- 7. FILLING CODE AND COLOUR BAND

MISCELLANEOUS (LAND SERVICE)

FIG. 1

MINE, ANTI-PERSONNEL No. 6, MK. I

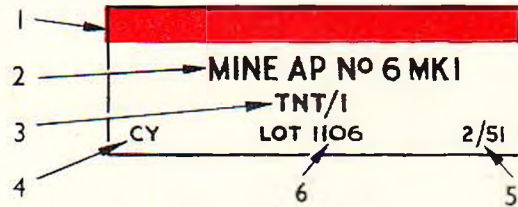
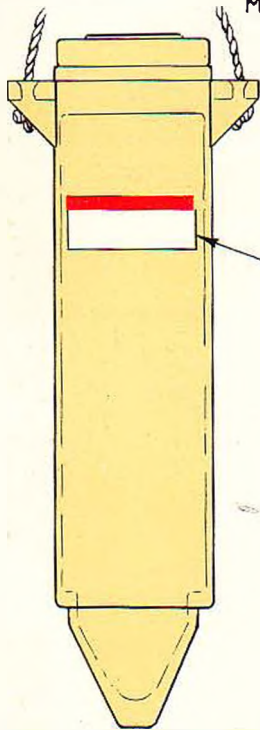

PAPER LABEL
(APPLIED ON INSIDE OF TRANSPARENT CASING)

- 1..... RED FILLING RING
- 2..... NOMENCLATURE AND MARK OF STORE
- 3..... CODE DENOTING NATURE OF MAIN EXPLOSIVE FILLING
- 4..... FILLERS RECOGNIZED MARK OR INITIALS
- 5..... DATE OF FILLING (MONTH AND YEAR)
- 6..... FILLED LOT NUMBER

FIG. 2

MINE, A/TK., MK. 7.

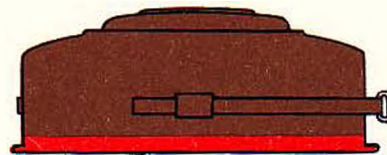

- 1..... RED FILLING RING
- 2..... NOMENCLATURE AND MARK OF STORE
- 3..... CODE DENOTING NATURE OF MAIN EXPLOSIVE FILLING
- 4..... FILLERS RECOGNIZED MARK OR INITIALS
- 5..... DATE OF FILLING (MONTH AND YEAR)
- 6..... FILLED LOT NUMBER

FUZE PARTICULARS

- 7..... NUMBER AND MARK OF FUZE
- 8..... FILLERS RECOGNIZED MARK OR INITIALS
- 9..... DATE OF FILLING (MONTH AND YEAR)
- 10..... LOT NUMBER OF FUZE

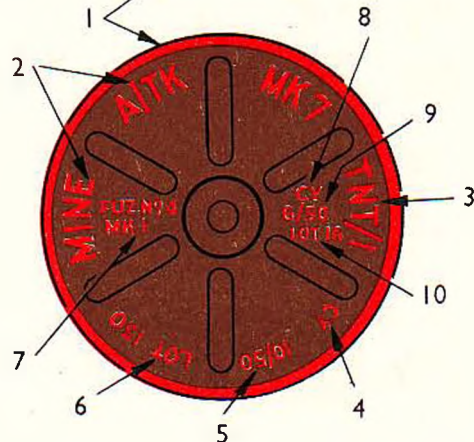

TYPICAL FUZE, MINE, A.TK. (LAND SERVICE)

FIG 1

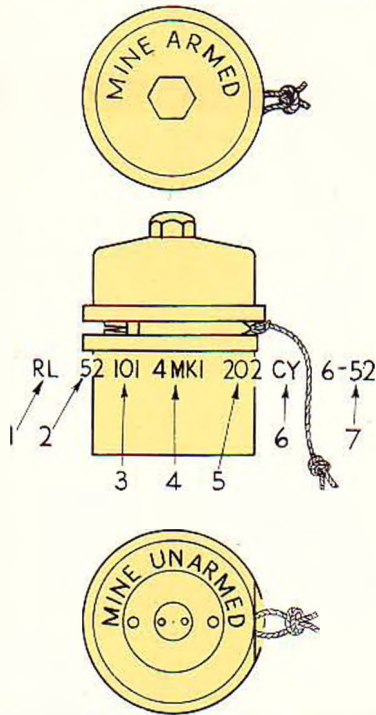

EMPTY DETAILS

- 1... MANUFACTURERS RECOGNIZED MARK
OR INITIALS
- 2... YEAR OF MANUFACTURE
- 3... SERIES LOT NUMBER
- 4... NUMBER AND MARK OF STORE

FILLED DETAILS

- 5... FILLED LOT NUMBER
- 6... FILLERS RECOGNIZED MARK
OR INITIALS
- 7... DATE OF FILLING (MONTH AND YEAR)

MISCELLANEOUS (LAND SERVICE)

FIG. 1

SWITCH, PULL No. 4, MK. 1

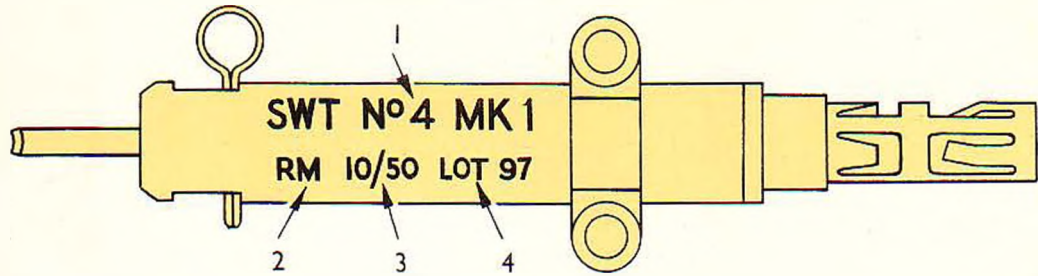

- 1..... NOMENCLATURE AND MARK OF STORE
- 2..... MANUFACTURERS RECOGNIZED MARK OR INITIALS
- 3..... DATE OF MANUFACTURE (MONTH AND YEAR)
- 4..... LOT NUMBER

FIG. 2

SNOUT, SWITCH, CAPPED MK. 1

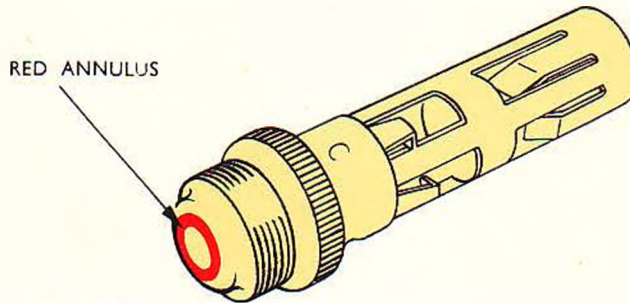

NOTE:-
DETAILS OF NOMENCLATURE , MARK OF STORE, MANUFACTURERS INITIALS AND LOT NUMBER ARE GIVEN ON OUTSIDE OF PACKAGE CONTAINING SWITCHES.

FIG. 3

SWITCH, TIME PENCIL No. 10, MK. 1

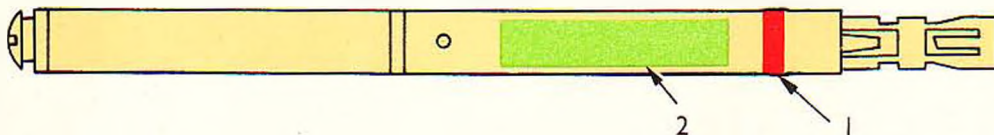

- 1..... RED FILLING RING
- 2..... COLOURED PATCH INDICATING TIME OF DELAY

NOTE:-
DETAILS OF NOMENCLATURE , MARK OF STORE, MANUFACTURERS INITIALS AND LOT NUMBER ARE GIVEN ON OUTSIDE OF PACKAGE CONTAINING SWITCHES

RESTRICTED

The information given in this document is not to be communicated, either directly or indirectly, to the Press or to any person not authorized to receive it.

W.O.
CODE No.

3421

**INTER-SERVICE
AMMUNITION
AND
AMMUNITION PACKAGE
MARKINGS**

1948

SECTION 8

Pyrotechnics

This Section having been approved by the Lords Commissioners of the Admiralty, by the Army Council and by the Air Council, is promulgated for information and guidance.

By Command of their Lordships.

J. G. Lang

By Command of the Army Council.

Lieut. R. B. Mudd.

By Command of the Air Council.

J. H. Barwell.

CONTENTS

	Para.	Page
Introduction—		
Principles of marking	2	5
Method of marking	3	5
Rings	4	5
Stencilling	5	6
Stamping, embossing and milling	6	6
Symbols	7	7
Labels, including metal tags	8	7
Bombs	—	8
Cartridges	—	9
Flares	—	10
Floats	—	11
Generators and candles	—	12
Grenades	—	13
Lights and projectiles	—	14
Markers	—	15
Miscellaneous	—	16
Rockets	—	17
Signals	—	18
Simulators	—	19

LIST OF PLATES

	Plate
Bombs	I
Cartridges	2
Flares	3
Floats	4
Generators and candles	5
Grenades	6
Lights and projectiles	7
Markers	8
Miscellaneous	9
Rockets	10
Signals	11
Simulators	12

INDEX

	Para.	Page
B		
Basic colours	3.1	5
combinations of	3.2	5
Bombs—list of	—	8
C		
Camouflage requirement	3.3	5
Candles and generators—list of	—	12
Cartridges and dischargers—list of	—	9
Colours—		
basic	3.1	5
combinations of	3.2	5
no identification significance	3.4	5
Combinations of colours	3.2	5
D		
Dischargers and cartridges—list of	—	9
E		
Embossing	6.2	6

	F	Para.	Page
Filling ring—			
Red		4.1	5
position of		4.2	6
type of		4.3	6
Flares—list of		—	10
Floats—list of		—	11
Functioning ring		4.4	6
	G		
Generators and candles—list of		—	12
Grenades—list of		—	13
	I		
Identification—no significance of colour		3.4	5
Information normally stencilled		5.1	6
Introduction		1	5
	L		
Labels—including metal tags		8	7
Lights and projectiles—list of		—	14
	M		
Markers—list of		—	15
Marking—			
methods of		3	5
principles of		2	5
“Method of functioning” ring		4.4	6
Methods of marking		3	5
Metal tags		8	7
Milling		6.3	7
Miscellaneous pyrotechnics—list of		—	16
	P		
Principles of marking		2	5
Projectiles and lights—list of		—	14
	R		
Red filling ring		4.1	5
position of		4.2	6
Rings		4	5
“method of functioning”		4.4	6
Red filling		4.1	5
position of		4.2	6
“type of filling”		4.3	6
Rockets—list of		—	17
	S		
Signals—list of		—	18
Simulators—list of		—	19
Stamping		6.1	6
Stencilling		5	6
information on pyrotechnics		5.1	6
Symbols		7	7
eyebrow		7.3	7
letter “P”		7.7	7
lightning		7.1	7
serpentine		7.2	7
stars		7.4-7.6	7
White zig-zag ring		7.8	7
	T		
Tags and labels		8	7
“Type of filling” ring		4.3	6

INTRODUCTION

1. This Section should be read in conjunction with Section 1, General Introduction.
2. The principles of marking in this section follow those laid down in the General Introduction.
There are exceptions, and these are explained by the examples.

3. METHOD OF MARKING

3.1. The basic colours are as follows :—

Colour	Nature of store with which used
Light Green	Smoke.
Red Oxide	Incendiary.
Red	Flame.
Grey	Chemical.
Black or natural finish	Signals.
Black	Flare, Flash or Radar Echo.
Black with Yellow ring	Practice.
White	Illuminating.
Aluminium	Aluminium markers.

- 3.2. Combinations of the basic colours are employed on stores of a composite nature, *e.g.*, smoke and flame stores are painted half Light Green, half Red.
Marine markers and floats have the portion above the water line painted bright Yellow when required to render them conspicuous for recovery.
- 3.3. Where camouflage is a requirement, the basic colour is disregarded and a specified camouflage scheme employed, *e.g.*, trip wire flare and marine markers.
- 3.4. Throughout this section, parts of stores which have no colour identification significance are depicted in Champagne.

4. RINGS

The coloured rings used on pyrotechnic stores are based on the standard sizes shown in Section 2. Where the standard sizes cannot be used because of the varied sizes and shapes of pyrotechnic stores, rings proportionate in size to the store will be used.

They are applied over the basic body colour to indicate :—

- (a) That the store contains an active agent and is classified for storage in an Explosive Group.
- (b) Type of filling.
- (c) Method of functioning.
- (d) Special features.

4.1. The Red filling ring

This denotes that the store is filled and contains an active agent.

- 4.1.1. Stores which are not classified in an Explosive Group for transport and storage will not have a Red filling ring.
- 4.1.2. Incendiary stores will have the Red filling ring superimposed on their Red Oxide basic colour. If flame stores, by virtue of being classed in an explosive, storage and transport group, require the Red filling ring it will be outlined by two Black hair lines on the basic colour.

4.2. *Position of Red filling ring*

This is placed near the nose or on the ogive.

4.3. *"Type of filling" ring*

Those normally found on pyrotechnic stores are :—

White	For White phosphorus.
Black, with the appropriate code marking such as B.2.		For chemical or lachrymatory.
Light Green, with the appropriate code marking such as G. 6.		For chemical smoke.
Yellow on a Black basic background	For practice.

The "type of filling" ring is normally applied on the body of the store.

4.4. *"Method of functioning" ring*

A Red ring denotes Base Emission. This is placed on the lower part of the body.

NOTE.—Where combination rings are used, *i.e.*, "type of filling" and "method of functioning" rings, the size and position are governed by those laid down in Section 2.

5. STENCILLING.

Where space is available, stencilling is used to complete general identification, if necessary, and to add detailed identification.

5.1. The information normally stencilled is coloured in sharp contrast to the basic body colour, and is as follows :—

- 5.1.1. The nomenclature, or an abbreviated form of it.
- 5.1.2. The lot number as applicable.
- 5.1.3. The date of filling (month and year).
- 5.1.4. Monogram of filling factory or firm.
- 5.1.5. In the case of coloured smoke stores, the colours, *e.g.*, Red, Green, Blue or Yellow, the lettering to be in White.

6. STAMPING, EMBOSING AND MILLING.

6.1. *Stamping* is utilized on certain metal and plastic stores to show the monogram of the manufacturer of the empty store and date of manufacture.

6.2. *Embossing* is used to facilitate identification of stores by touch, *i.e.*, night identification. It is not a requirement for Air Service stores.

Subject to space being available, the following symbols are embossed :—

6.2.1. *Cartridges, signal—*

Single stars—

Red are indicated by	+
Green are indicated by	△
Yellow or White are indicated by	○

Two or more stars—

Red and Green are indicated by	+ △
Green and Yellow	△ ○
Red and Yellow	+ ○
Red and Red	+ +
Green and Green	△ △
Yellow and Yellow or	○ ○
White and White	} ○ ○

6.2.2. Bombs, signal or illuminating—

Single stars—

Red are indicated by +
 Green are indicated by Δ

Multi-star—

White are indicated by ○ ○
 Red are indicated by + +
 Green are indicated by Δ Δ
 Red and Green are indicated by + Δ

Illuminating with parachute is indicated by P
Signal Success is indicated by S

6.2.3. The embossing will normally be found on the ends of the store or on the body, except for 1-inch signal cartridges used in Naval Service.

6.3. Milling.—1-inch signal cartridges in Naval Service are identified by milling as follows :—

Green star or stars ... The rim of the cartridge is left plain.
 White star or stars ... The rim of the cartridge is milled around half the circumference.
 Red star or stars ... The whole circumference of the rim is milled.

7. SYMBOLS.

Coloured rings, stars, tips and other symbols and stencilling, not of general application are used to indicate special features. These are :—

- 7.1. A lightning symbol in White denotes a photographic flash.
- 7.2. A serpentine symbol, colour as applicable, denotes a smoke puff.
- 7.3. An eyebrow symbol, colour as applicable, surrounding the initial letter of the colour, denotes a tracer is included and its colour.
- 7.4. A star symbol, colour as applicable, denotes the colour of the star unit.*
- 7.5. A star symbol, parti-coloured, denotes a change colour star unit.*

* NOTE.—The over-printed numeral denotes the number of stars present. The colour shown on the top half of parti-coloured stars is the colour of the star that appears first on ejection.

- 7.6. A star symbol, with the letter " M " (multiple) superimposed, denotes the presence of more than two star units when the exact number is unimportant.
- 7.7. The letter " P " denotes that a signal or flare is suspended from a parachute. The Mark of parachute, where applicable, is used with the letter, e.g., P.6.
- 7.8. A White zig-zag ring of double standard width on the head denotes a radar echo.

8. LABELS, INCLUDING METAL TAGS.









- 8.1. Where pyrotechnic stores such as special purpose cartridges, engine starter cartridges, air/sea rescue rockets, portfires, simulators, thunder flashes and certain commercial stores, do not lend themselves to the foregoing methods of marking, labels and tags are used for identification or to denote their use.
- 8.2. Special warning or instructional labels or tags are used as necessary.

BOMBS

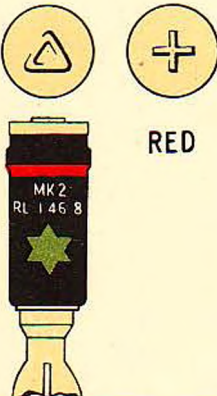
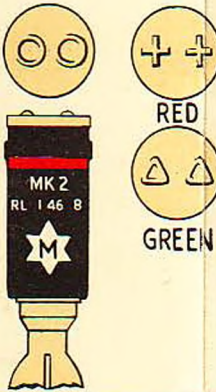











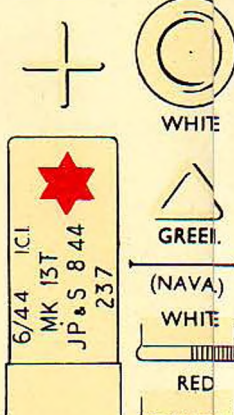

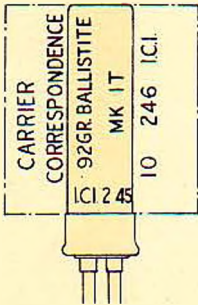
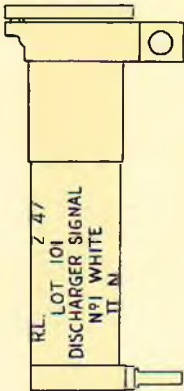

(Plate 1)

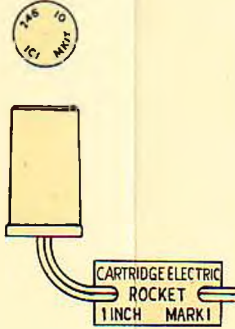
Fig. No.	Nature of Store	Service	Remarks
1	Bombs— M.L. smoke, 2-in. mortar Smoke, 2-in. bomb thrower	LN LN	2" MOR or 2" B.T., as applicable, stencilled on base.
2	M.L. smoke, 2-in. mortar— Red or Blue or Yellow or Green... Smoke, 2-in. bomb thrower— Red or Blue or Yellow or Green...	L L	do. do.
3	Smoke, bursting, 2-in. bomb thrower	LN	do.
4	Signal— M.L. 2-in. mortar— Single star, Red or Green ...	LN	do.
5	Multi-star, Green or Red or White	—	
6	Multi-star, Red and Green ...	L	do.
7	Success, change colour Red to Green	LN	do.
8	Star, with parachute	LN	do.
9	Incendiary— 1½-lb.	L	
10	Aircraft, target indicating, 250-lb. ...	A	When bombs contain coloured candle, lettering to denote the colour is stencilled in White around the bomb nose.

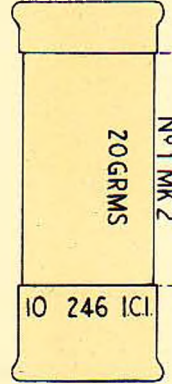

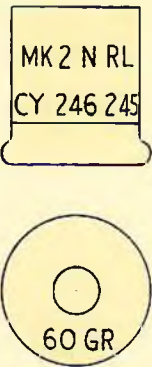



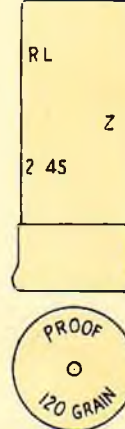
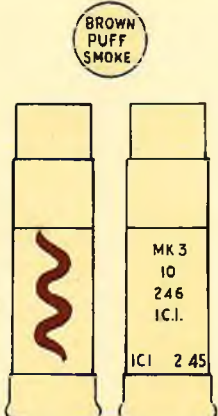





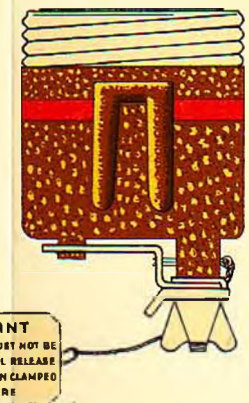

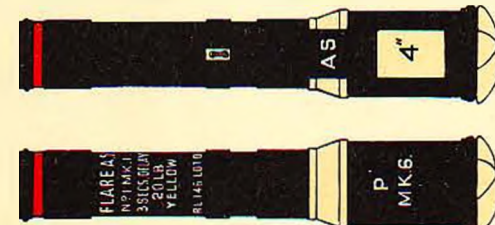
BOMBS.

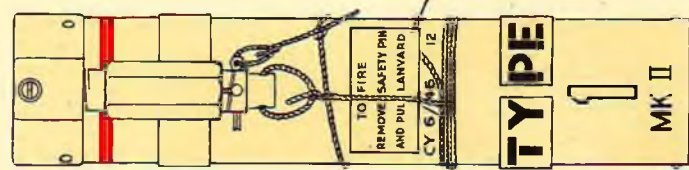
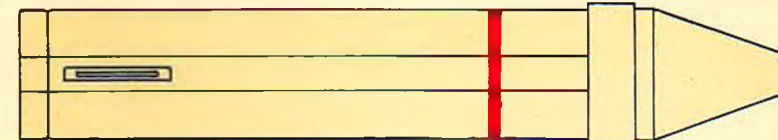
1. SMOKE EMISSION.	2. COLOURED SMOKE EMISSION.	3. SMOKE BURSTING W P	4. SIGNAL SINGLE STAR RED OR GREEN.
			 <p>RED</p>
5. SIGNAL MULTI- GREEN, RED OR WHITE.	6. SIGNAL MULTI-STAR RED & GREEN.	7. SIGNAL SUCCESS.	8. STAR WITH PARACHUTE.
 <p>RED GREEN</p>		 <p>S</p>	 <p>P</p>
9. INCENDIARY.	10. AIRCRAFT TARGET INDICATOR.		
 <p>TAPE.</p> <p>BOMB INCENDIARY MARK I INSTRUCTIONS FOR USE REMOVE TAPE AND SAFETY COVER AND STRIKE CAPS SLANTING DOWN ON A HARD SURFACE. THROW OR PLACE IMMEDIATELY WHERE REQUIRED. THERE IS A 5 SECOND DELAY. RL 145 8</p>			
			<p>NOTES. X COMPOSITION CODE + NUMBER OF PARACHUTE AS APPLICABLE</p>











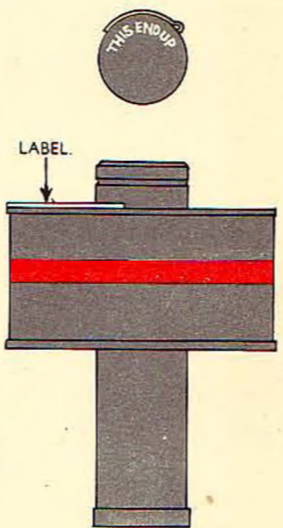

CARTRIDGES AND DISCHARGERS.

1. ILLUMINATING 1-INCH.	2. ILLUMINATING 1/2-INCH.	3. SIGNAL, GREEN OR RED OR WHITE.	4. SIGNAL, CHANGE COLOUR, YELLOW TO GREEN.	5. SIGNAL, RED.	6. SIGNAL, DOUBLE STAR.	7. SIGNAL, GREEN & RED.
						
<p>8. CARRIER CORRESPONDENCE.</p>	<p>9. DISCHARGERS, WHITE FOR TYPE A SIGNAL APPARATUS.</p>	<p>10. ELECTRIC, ACTUATING FLOATATION GEAR.</p>	<p>11. ELECTRIC, 60 GRAIN.</p>	<p>12. ELECTRIC, IGNITION.</p>	<p>13. EMERGENCY, UNDERCARRIAGE.</p>	<p>14. ENGINE STARTER.</p>
						
<p>15. PERCUSSION.</p>	<p>16. PERCUSSION, 60 GRAIN.</p>	<p>17. PHOTOGRAPHIC FLASH.</p>	<p>18. PROOF.</p>	<p>19. PROOF, ELECTRIC, 120 GRAIN.</p>	<p>20. PROOF, PERCUSSION, 120 GRAIN.</p>	<p>21. SMOKE PUFF.</p>
						

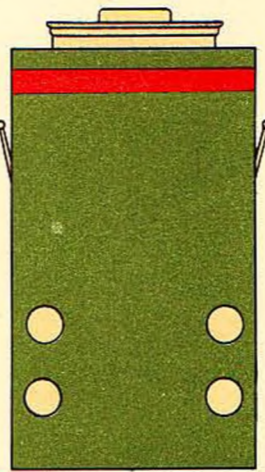
FLARES.

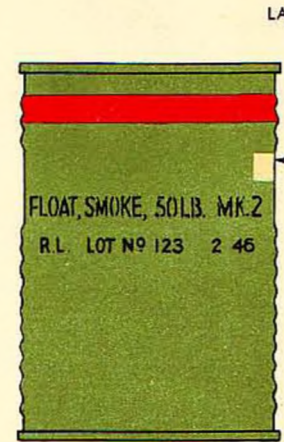
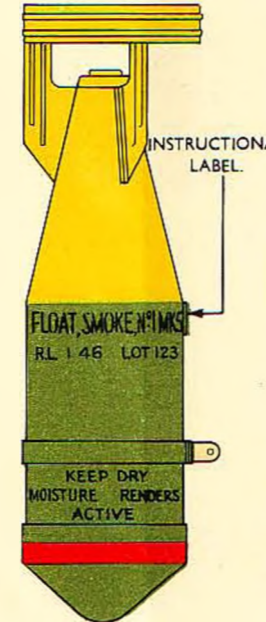
<p>1. SIGNAL, GREEN OR RED.</p> 	<p>2. SIGNAL, TYPE "A" APPARATUS, WHITE.</p> 	<p>3. TRIP WIRE.</p> 	<p>4. GROUND ILLUMINATOR, A/C</p> 
<p>5. GROUND, WARNING AND INDICATING.</p> 	<p>6. AIRCRAFT, A/S, 4-INCH.</p> 	<p>9. RECONNAISSANCE, 4-INCH.</p> 	
<p>7. IDENTIFICATION, TYPES 1, 2 AND 3.</p> 	<p>8. ILLUMINATOR, No. 1.</p> 	<p>12. 7-INCH, HOODED.</p> 	
<p>10. RECONNAISSANCE, 4.5-INCH.</p> 	<p>11. SKYMARKER, 4.5-INCH.</p> 	<p>13. PROOF OF FUZES.</p> 	
<p>13. PROOF OF FUZES.</p> 	<p>14. TARGET, 4.5-INCH</p> 	<p>14. TARGET, 4.5-INCH</p> 	

FLOATS.

1. FLAME, DELAY.	2. FLAME, A/C NAVIGATION.	3. FLAME, NAVIGATION OR MESSAGE CARRYING.	4. FLAME, NAVIGATION, No. 3.	5. LACHRYMATORY.	6. SMOKE, TYE R.M.	7. SMOKE, 60LB.
 <p>FLOAT, FLAME DELAY MK I N R.L. 2 46 123</p> <p>INSTRUCTIONS FOR USE PUNCTURE CENTRE OF WHITE DISC WITH PIERCING TOOL UNSCREW IGNITER COVER PULL LOOP TO FIRE REPLACE IGNITER COVER TIGHTLY FLARE IGNITES AFTER A DELAY OF ABOUT 15 MINUTES.</p>	 <p>FLOAT, FLAME, NAVIGATION MK I R.L. 1/46 LOT 123</p>	 <p>KEEP DRY MOISTURE INDUCES IGNITION.</p> <p>FLOAT, FLAME, NAVIGATION MK 2 R.L. 1/46 LOT 123</p>	 <p>INSTRUCTIONAL LABEL</p> <p>FLOAT, FLAME NAVIGATION No. 3 R.L. 1 46 KEEP DRY MOISTURE INDUCES IGNITION</p>	 <p>LACHRYMATORY</p> <p>THIS END UP</p>	 <p>LBS THIS END UP 123 R.L. 1-6</p> <p>FLOAT, SMOKE, MK VII NOT TO BE STOWED BETWEEN DISKS</p>	
8. SMOKE, NAVIGATION.	9. SMOKE, 50LB.	10. SMOKE, A/C, No. 1.	11. SMOKE, A/C, No. 2.	12. SIGNAL, SUBMERGED.	13. SMOKE & FLAME.	
 <p>THIS END UP</p> <p>13 LBS. R.L. 2 46 123 I M</p>	 <p>FLOAT, SMOKE, 50 LB. MK. 2 R.L. LOT No 123 2 46</p> <p>LABEL</p>	 <p>INSTRUCTIONAL LABEL</p> <p>FLOAT, SMOKE, No. 1 MK 1 R.L. 1 46 LOT 123</p> <p>KEEP DRY MOISTURE RENDER'S ACTIVE</p>	 <p>FLOAT, SMOKE, No. 2 MK 2 R.L. 1 46 LOT 123</p>	 <p>LABEL</p> <p>IMPALER PRESSURE TO BE USED 500 LB. PER SQUARE IN.</p> <p>II N R.L. 1 46 F S S</p>	 <p>FLOAT, SMOKE & FLAME 3 1/2 LB. No. 1 MK I R.L. 2 46 LOT 123</p>	

CARTRIDGES AND DISCHARGERS

(Plate 2)

Fig. No.	Nature of Store	Service	Remarks
1	Cartridges— Illuminating— 1-in.	LN	<i>General Note</i> No Red filling ring is placed on these stores owing to their small size.
2	1½-in.	AN	
3	Signal— 1-in. Green or Red or White ...	LN	
4	1½-in. change colour, Yellow to Green	A	
5	Red	AN	
6	Double star	AN	
7	Green and Red	AN	
8	Carrier, correspondence	A	
9	Dischargers, White for Type " A " signal apparatus.	N	
10	Cartridges— Electric— Actuating flotation gear	NA	
11	60-grain	N	
12	Ignition	A	
13	Emergency, undercarriage	A	
14	Engine starter	AN	
15	Percussion	A	
16	60-grain	NA	
17	Photographic flash	A	
18	Proof	A	
19	Electric, 120-grain	N	
20	Percussion, 120-grain	N	
21	Smoke puff	AN	

FLARES

(Plate 3)

Fig. No.	Nature of store	Service	Remarks
1	Flare— Signal— Green or Red 	N	
2	Type " A " apparatus, White ...	N	
3	Trip wire 	LN	Has a mottled body for camouflage purposes.
4	Ground illuminator, A/C 	A	Descriptive and instructional label AID. 56 is secured to the top.
5	Ground, warning and indicating ...	AN	Descriptive and instructional legends are tin-printed on the body :— Red printing for warning. Yellow printing for indicating flare.
6	Aircraft, A/S, 4-in. 	AN	
7	Identification, types 1, 2 and 3 ...	N	
8	Illuminator, No. 1 	A	Descriptive label H. 1411 secured to diaphragm closing recess.
9	Reconnaissance, 4-in. 	AN	
10	Reconnaissance, 4.5-in. 	AN	
11	Skymarker, 4.5-in. 	AN	
12	7-in., hooded 	A	
13	Proof of fuzes 	A	
14	Target, 4.5-in. 	A	

FLOATS

(Plate 4)

Fig. No.	Nature of Store	Service	Remarks
1	Float— Flame— Delay 	N	
2	A/C navigation 	AN	
3	Navigation or message carrying ...	A	"MESSAGE HERE" is stencilled adjacent to the removable plug.
4	Navigation, No. 3 	A	
5	Lachrymatory 	N	
6	Smoke— Type, R.M. 	N	
7	60-lb. 	N	
8	Navigation, 13-lb. 	N	
9	50-lb. 	L	
10	A/C— No. 1 	AN	
11	No. 2 	AN	
12	Signal, submerged 	N	
13	Smoke and flame 	A	

GENERATORS AND CANDLES



(Plate 5)

Fig. No.	Nature of store	Service	Remarks
1	Generator— Chemical, No. 20 or No. 30	L	
2	Smoke— No. 5	AN	
3	No. 6	AN	
4	No. 8	LN	
5	No. 15	AN	
6	No. 16	N	
7	Nos. 19, 24 and 28	LN	
8	No. 26, Blue, Red or Yellow	N	
9	Lachrymatory— No. 1	N	
10	No. 2	LN	
11	Candle— Smoke— White	N	
12	Yellow... ..	N	
13	Red, message carrying	N	

GENERATORS AND CANDLES.

<p>1. GENERATOR, CHEMICAL.</p>	<p>2. GENERATOR, SMOKE, No. 5.</p>	<p>3. GENERATOR, SMOKE, No. 6</p>	<p>4. GENERATOR, SMOKE, No. 8</p>
<p>5. GENERATOR, SMOKE, No. 15.</p>	<p>6. GENERATOR, SMOKE, No. 16.</p>	<p>7. GENERATOR, SMOKE, Nos. 19, 24, 28.</p>	<p>8. GENERATOR, SMOKE, No. 26.</p>
<p>9. GENERATOR, LACHRYMATORY No. 1.</p>	<p>10. GENERATOR, LACHRYMATORY No. 2.</p>	<p>11. CANDLE, SMOKE, WHITE.</p> <p>12. CANDLE, SMOKE, YELLOW.</p> <p>13. CANDLE, SMOKE, RED, MESSAGE CARRYING.</p>	

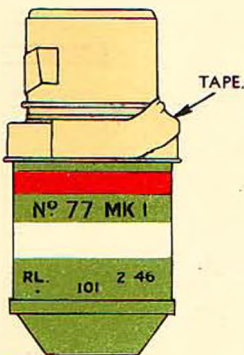
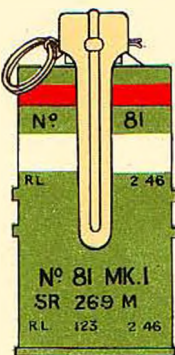
GRENADES.

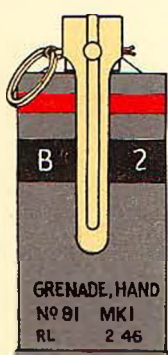
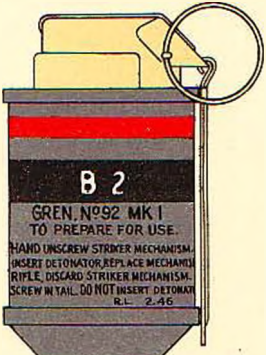
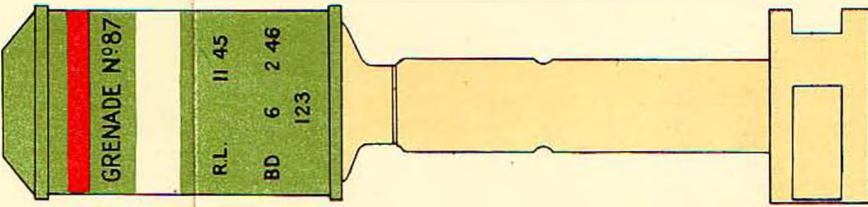
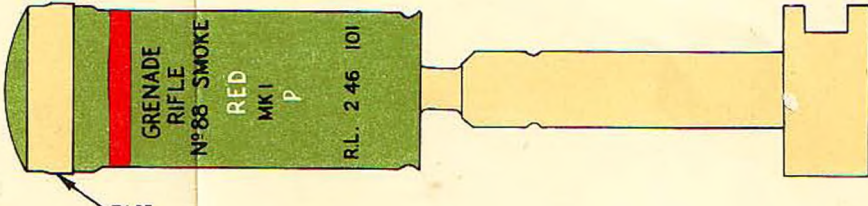
1. SIGNAL, No. 65	2. HAND, No. 77, SMOKE, W P	3. HAND, No. 81, SMOKE, W P
		
4. HAND, COLOURED SMOKE.	5. HAND, No. 91, CHEMICAL.	6. HAND OR RIFLE, No. 92, CHEMICAL.
		
7. RIFLE, SMOKE, No. 87, W P		
		
8. RIFLE No. 88. COLOURED SMOKE.		
		

GRENADES

(Plate 6)

Fig. No.	Nature of Store	Service	Remarks
1	Grenade— Signal, No. 65, types 1, 2 and 3 ...	N	
2	Hand— No. 77, smoke, WP	L	
	No. 79, smoke, WP	L	
3	No. 81, smoke, WP	L	Has a White ring on W.P. component and the composition number on the H.C.E. component.
4	No. 83, smoke, Blue or Green or Red or Yellow.	LN	
5	No. 91, chemical	LN	
6	Hand or rifle, No. 92, chemical ...	L	As the grenade and tail unit are packed and issued separately the tail unit has its own Red ring denoting that it contains an active agent. Descriptive and instructional legend tin-printed on body.
7	Rifle— Smoke, No. 87, WP	L	
8	No. 88, Red or Blue or Yellow or Green.	I.N	

LIGHTS AND PROJECTILES

(Plate 7)

Fig. No.	Nature of Store	Service	Remarks
1	Light— Long, Blue or Red	N	
2	Short, G.S.	N	
3	Projectile— Signal— White, M.L., 3-in. mortar	AN	

LIGHTS AND PROJECTILES.

1. LIGHT.

LONG, RED

OR BLUE AS APPLICABLE.



2. LIGHT.

SHORT, G.S.

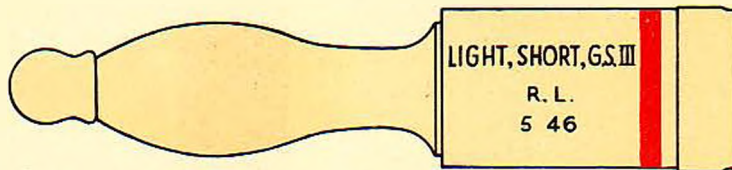



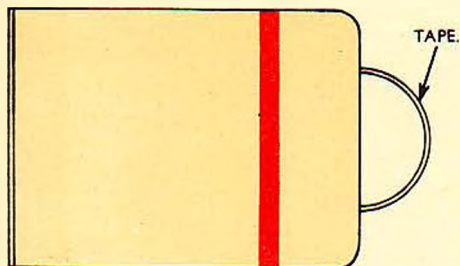

3. PROJECTILE.

SIGNAL.

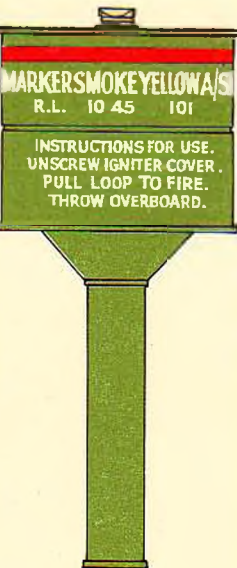

MARKERS.

1. SMOKE, WHITE, A/S.	2. SMOKE, YELLOW, A/S.	3. MARINE, A. C. No. 2.	4. SEA, ALUMINIUM.
			
<p>5. MARINE, A/C, No. 3.</p> 			

MARKERS

(Plate 8)

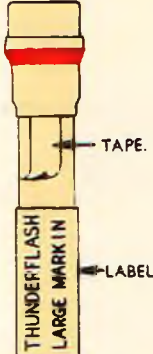

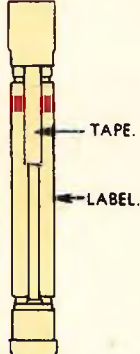



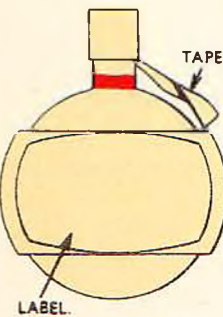

Fig. No.	Nature of Store	Service	Remarks
1	Markers— Smoke— White, A/S	N	
2	Yellow, A/S	N	
3	Marine, A/C, No. 2	AN	Portion above water line painted Yellow to render conspicuous for recovery.
4	Sea, aluminium	A	
5	Marine, A/C, No. 3	A	It is painted Dark Battleship Grey to render it less conspicuous.

MISCELLANEOUS

(Plate 9)

Fig. No.	Nature of Store	Service	Remarks
1	Thunderflash	LNA	
2	Portfire— Common	LNA	
3	Friction	AN	Has labels H. 1548 and H. 1213 affixed.
4	Cracker, Chinese	N	Marked "TRAINING".
5	Flash, photographic, A/C. 4.5-in. ...	A	The tail is painted Red as a warning to those handling it that it is a specially dangerous store.
6	Fuze, destroying, M type, balloons ...	A	
7	Puff, powder, friction ignited— No. 11	A	
8	No. 9	LNA	
9	No. 10	AN	

MISCELLANEOUS.

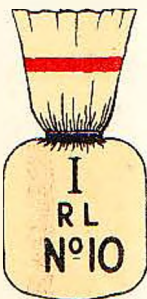
1. THUNDER FLASH.	2. PORTFIRE, COMMON.	3. PORTFIRE, FRICTION	4. CRACKER, CHINESE.
			
5. FLASH, PHOTOGRAPHIC.			
			
6. FUZE, DESTROYING, M TYPE, BALLOONS.	7. PUFF, POWDER, FRICTION IGNITED, No. 1	8. PUFF, POWDER FRICTION IGNITED, No. 9	9. PUFF, POWDER, FRICTION IGNITED, No. 10
			

ROCKETS.

1. BUOYANT, LINE CARRYING, No. 1 OR 2.



2.

ILLUMINATING, 9 LB.

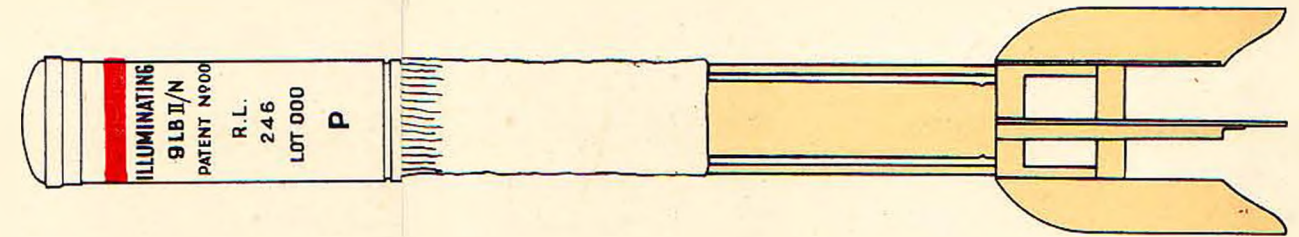

3. ILLUMINATING, 6 1/4 LB., No. 1.

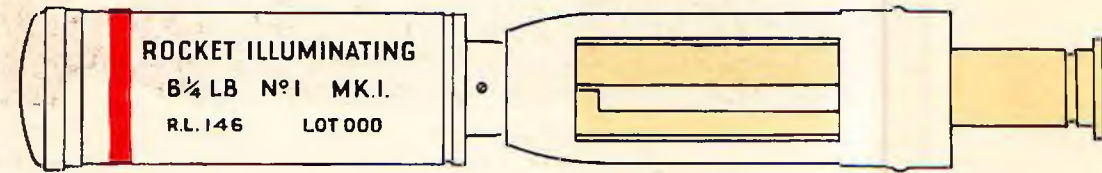

4.

LINE CARRYING, SCHERMULY 1LB. AND 2LB.



5. SIGNAL, 1 LB., RED OR GREEN

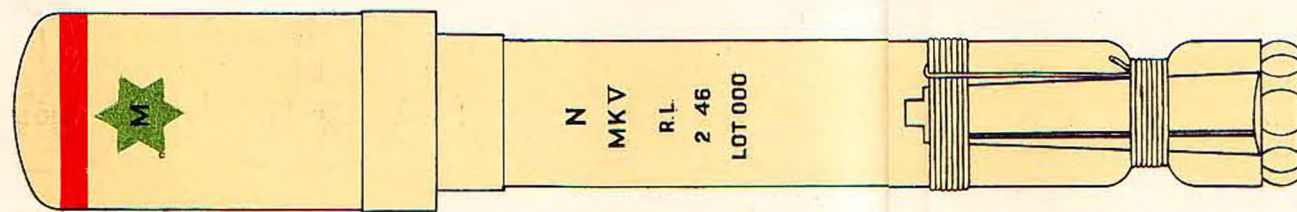

6.

SIGNAL, 1 LB., SERVICE.

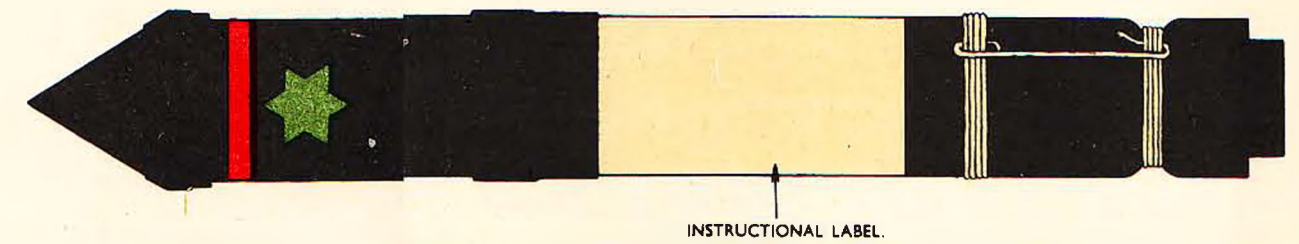

7. TARGET, PRACTICE, 1 LB.



ROCKETS

(Plate 10)

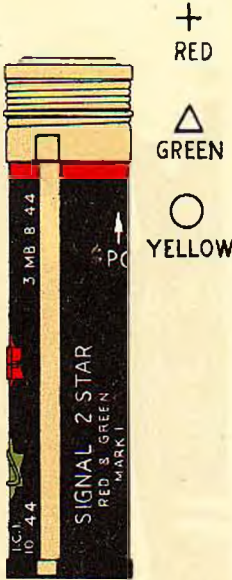

Fig. No.	Nature of store	Service	Remarks
1	Rocket— Buoyant, line carrying, No. 1 or 2	NA	Is painted Yellow to make it conspicuous in water.
2	Illuminating— 9-lb.	N	
3	6½-lb., No. 1	A	
4	Line carrying, Schermuly 1-lb. and 2-lb.	N	
5	Signal— 1-lb., Red or Green	N	
6	1-lb., service	NA	
7	Target, practice, 1-lb.	N	

SIGNALS

(Plate 11)

Fig. No.	Nature of Store	Service	Remarks
1	Signal— Two star, Red and Green	L	Descriptive and instructional legend is tin-printed on body.
	Ten star, either ten Red, ten Green, ten Yellow or five Red and five Green or five Red and five Yellow.	L	
	Double star, Red-Green, Red and Green.	LN	
2	Distress, two star Red	NA	
3	Illuminating	L	
4	Single star, Red, Green or Yellow ...	LN	

SIGNALS.

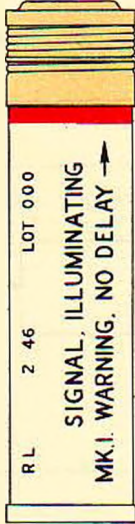
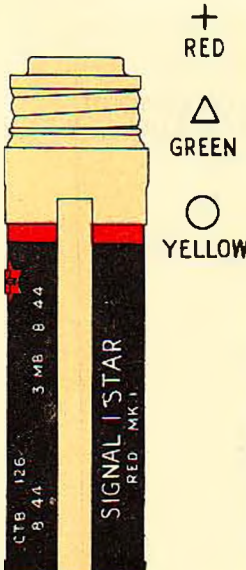
1. 2 STAR, RED AND GREEN.	2. DISTRESS, TWO STAR RED	3. ILLUMINATING.
 <p>+</p> <p>RED</p> <p>△</p> <p>GREEN</p> <p>○</p> <p>YELLOW</p>		
4. SINGLE STAR, RED, GREEN OR YELLOW.		
 <p>+</p> <p>RED</p> <p>△</p> <p>GREEN</p> <p>○</p> <p>YELLOW</p>		

SIMULATORS.

1. GUN-FLASH, No. 1.

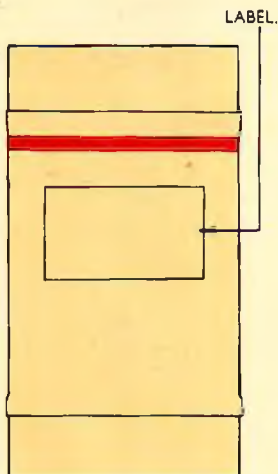

2. GUN-FLASH, No. 3.



3. MACHINE GUN, A/B, No. 1.

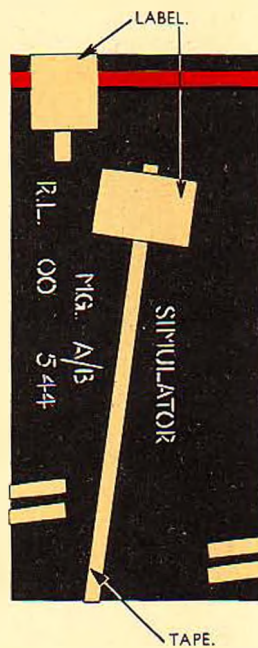

4. RIFLE FIRE, AIRBORNE, No. 1.

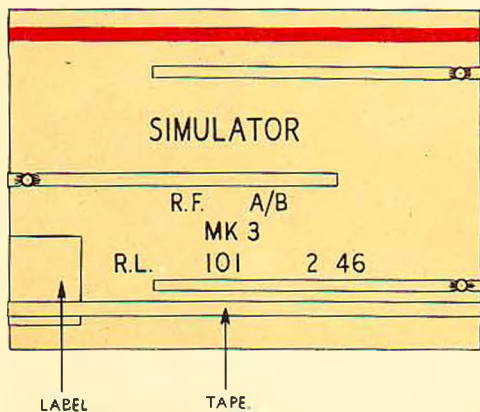

5. COMPOSITE, FIELD, No. 1A, 1B, & 1C.

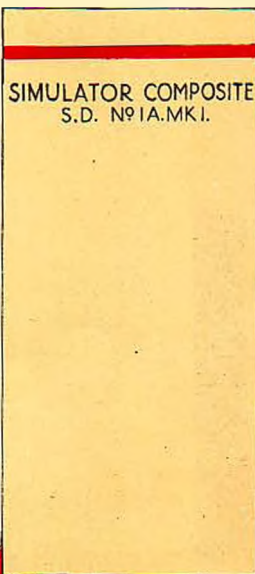

SIMULATORS

(Plate 12)

Fig. No.	Nature of Store	Service	Remarks
1	Simulator— Gun-Flash— No. 1 	LN	Has label H. 1537 affixed. Electric ignition.
2	No. 3 	LN	Has label H. 1539 affixed. Electric or safety fuze ignition.
3	Machine gun, A/B, No. 1 	LN	Stencilling is in White or Yellow. Labels and tags are also used.
4	R.F., A/B, No. 1 	LN	
5	Composite, Fd., No. 1A, 1B and 1C ...	LN	