

---

This is a reproduction of a library book that was digitized by Google as part of an ongoing effort to preserve the information in books and make it universally accessible.

Google™ books

<https://books.google.com>



> 101.11:  
10-4510-201-14

TM 10-4510-201-14

DEPARTMENT OF THE ARMY TECHNICAL MANUAL

---

UNIVERSITY OF VIRGINIA  
ALDERMAN LIBRARY

JAN 18 1991

GOVERNMENT DOCUMENTS

TECHNICAL MANUAL

OPERATOR, ORGANIZATIONAL, DIRECT SUPPORT AND  
GENERAL SUPPORT MAINTENANCE MANUAL

BATH UNIT, PORTABLE, 8-SHOWER HEAD, M1958  
ORR & SEMBOWER MODEL 8-SH-1, ARMY MODEL SPE 35,  
FSN 4510-679-6493

YORK-SHIPLEY MODEL 8-SH-60, ARMY MODEL SPE-35A,  
FSN 4510-806-9555

YORK-SHIPLEY MODEL 8-SH-62, ARMY MODEL SPE 41,  
FSN 4510-856-8610

YORK-SHIPLEY MODEL 8-SH-63, ARMY MODEL SPE 44,  
FSN 4510-994-9955

YORK-SHIPLEY MODEL YS49279,  
FSN 4510-168-1930

YORK-SHIPLEY MODEL 8-SH-70YS, ARMY MODEL SPE 45,  
FSN 4510-418-4774

This copy is a reprint which includes current  
pages from Changes 1 through 7.

---

HEADQUARTERS, DEPARTMENT OF THE ARMY

JANUARY 1972

Digitized by Google

**WARNING  
ELECTRICAL SHOCK**

Disconnect power cords before performing any maintenance on the water heater and the water pump.

**WARNING  
ELECTRICAL SHOCK**

Make certain the generator set is properly grounded before operating. Serious and possible fatal shock may result from contact with components carrying current while the bath unit is operating.

**WARNING  
EXPLOSION HAZARD**

To eliminate the possibility of explosion and injury to personnel by the accumulation of excess fuel vapors in the hot water heater combustion chamber during emergency shutdown or failure of the electrical power supply, the following steps will be taken before resuming normal operation:

- a. Close burner fuel shutoff valve immediately.
- b. Disconnect ignition electrodes at combustion chamber.
- c. Restart unit and allow combustion chamber to be air purged for not less than three minutes before shutdown.
- d. Reconnect ignition electrodes, and resume normal operation.

**WARNING  
FIRE HAZARD**

Keep the fire extinguisher present, filled, and in operating condition so it can be used immediately in case of fire. When the extinguisher is not in use, keep it properly and securely mounted in its bracket on the baseboard.

**WARNING  
FIRE HAZARD**

Do not permit oily waste or cleaning rags, oil, grease, fuel, rubbish or trash to collect around the bath unit as they create fire hazards.

**WARNING  
FIRE HAZARD**

Keep constant watch for fuel leaks during bath unit operation, as leaking fuel may cause a fire hazard. Never refuel or handle gasoline or fuel oil when the bath unit is in operation. If fuel is spilled, it may cause a fire hazard. When refilling the fuel tank, do not smoke or use an open flame in the vicinity.

**WARNING  
PERSONAL INJURY**

Do not throw water on fire caused by defective electrical equipment as shock may result. Shut down the power source, and use CO<sub>2</sub> fire extinguisher, sand, or dirt to put out the fire.

**WARNING  
PERSONAL INJURY  
OR  
DEATH**

Direct the exhaust fumes outside to assure proper ventilation when operating the bath unit in a shelter or in a confined enclosure. Exhaust fumes are poisonous.

**WARNING  
PERSONAL INJURY**

Avoid coming in contact with the water heater exhaust duct during unit operation. The duct becomes extremely hot during operation, and serious burns or body injury may result from contact with the duct before it cools.

**WARNING  
DISEASE HAZARD**

Operate the bath unit in conjunction with the water treatment procedures approved by the major command surgeon when the bath unit is used in areas where schistosomiasis is prevalent. Failure to do so may result in contracting schistosomiasis, an infectious disease, which may prove detrimental to humans. See TB MED 167.

CHANGE }  
NO. 7 }

HEADQUARTERS  
DEPARTMENT OF THE ARMY  
WASHINGTON, D.C., 24 June 1988

Operator, Organizational, Direct Support  
and General Support Maintenance Manual

BATH UNIT, PORTABLE, 8-SHOWER HEAD, M1958  
(ORR & SEMBOWER MODEL 8-SH-1, ARMY MODEL SPE35)  
NSN 4510-00-679-6493  
(YORK-SHIPLEY MODEL 8-SH-60, ARMY MODEL SPE35A)  
NSN 4510-00-806-9555  
(YORK-SHIPLEY MODEL 8-SH-62, ARMY MODEL SPE41)  
NSN 4510-00-856-8610  
(YORK-SHIPLEY MODEL 8-SH-63, ARMY MODEL SPE44)  
NSN 4510-994-9955  
(YORK-SHIPLEY MODEL YS49279)  
NSN 4510-00-168-1930  
(YORK-SHIPLEY MODEL 8-SH-70-YS, ARMY MODEL SPE45)  
NSN 4510-00-418-4774  
(YORK-SHIPLEY MODEL YS74)  
NSN 4510-01-003-0350  
(YORK-SHIPLEY MODEL YS-8-SH-76)  
NSN 4510-01-032-3957  
(ORR & SEMBOWER MODEL 8-SH-1LP)  
NSN 4510-01-027-2123  
(YORK-SHIPLEY MODEL 8-SH-60LP)  
NSN 4510-01-016-5914  
(YORK-SHIPLEY MODEL 8-SH-62LP)  
NSN 4510-01-021-7421  
(YORK-SHIPLEY MODEL 8-SH-63LP)  
NSN 4510-01-016-3332  
(YORK-SHIPLEY MODEL YS49279LP)  
NSN 4510-01-016-5915  
(YORK-SHIPLEY MODEL 8-SH-70YSLP)  
NSN 4510-01-022-6920  
(YORK-SHIPLEY MODEL YS-74LP)  
NSN 4510-01-074-5177  
(YORK-SHIPLEY MODEL 8-SH-76LP)  
NSN 4510-01-080-2402

TM 10-4510-201-14, 11 January 1972, is changed as follows:

---

**REPORTING ERRORS AND RECOMMENDING IMPROVEMENTS**

You can help improve this manual. If you find any mistake or if you know of a way to improve the procedures, please let us know. Mail your letter, DA Form 2028 (Recommended Changes to Publications and Blank Forms), or DA Form 2028-2 located in the back of this manual direct to: Commander, U.S. Army Troop Support Command, ATTN: AMSTR-MCTS, 4300 Goodfellow Boulevard, St. Louis, MO 63120-1798. A reply will be furnished directly to you.

---

Page 1-1, Para 1-2. "TM 38-750" is changed to read "DA PAM 738-750."

Page 4 of Change 5; remove Item 1, Generator Set, Gasoline Engine, 3KW, AC, 60HZ, SF 3.0 MD with Canvas Cover, NSN 6115-00-017-8237, from Section II and insert into Section III, above Extinguisher data.

**By Order of the Secretary of the Army:**

**CARL E. VUONO**  
*General, United States Army*  
*Chief of Staff*

**Official:**

**R. L. DILWORTH**  
*Brigadier General, United States Army*  
*The Adjutant General*

**DISTRIBUTION:**

To be distributed in accordance with DA Form 12-25A, Operator, Unit, Direct Support and General Support Maintenance Requirements for Bath Unit, Portable, 8 Shower Head, M1958.

Change }  
No. 6 }

HEADQUARTERS  
DEPARTMENT OF THE ARMY  
WASHINGTON, D.C., 18 June 1982

**OPERATOR'S, ORGANIZATIONAL, DIRECT SUPPORT AND  
GENERAL SUPPORT MAINTENANCE MANUAL**

**BATH UNIT, PORTABLE, 8-SHOWER HEAD, M1958  
(ORR & SEMBOWER MODEL 8-SH-1, ARMY MODEL SPE35)  
NSN 4510-00-679-6493  
(YORK-SHIPLEY MODEL 8-SH-60, ARMY MODEL SPE35A)  
NSN 4510-00-806-9555  
(YORK-SHIPLEY MODEL 8-SH-62, ARMY MODEL SPE41)  
NSN 4510-00-856-8610  
(YORK-SHIPLEY MODEL 8-SH-63, ARMY MODEL SPE44)  
NSN 4510-994-9955  
(YORK-SHIPLEY MODEL YS49279)  
NSN 4510-00-168-1930  
(YORK-SHIPLEY MODEL 8-SH-70-YS, ARMY MODEL SPE45)  
NSN 4510-00-418-4774  
(YORK-SHIPLEY MODEL YS74)  
NSN 4510-01-003-0350  
(YORK-SHIPLEY MODEL YS-8-SH-76)  
NSN 4510-01-032-3957  
(ORR & SEMBOWER MODEL 8-SH-1LP)  
NSN 4510-01-027-2123  
(YORK-SHIPLEY MODEL 8-SH-60LP)  
NSN 4510-01-016-5914  
(YORK-SHIPLEY MODEL 8-SH-62LP)  
NSN 4510-01-021-7421  
(YORK-SHIPLEY MODEL 8-SH-63LP)  
NSN 4510-01-016-3332  
(YORK-SHIPLEY MODEL YS49279LP)  
NSN 4510-01-016-5915  
(YORK-SHIPLEY MODEL 8-SH-70YSLP)  
NSN 4510-01-022-6920  
(YORK-SHIPLEY MODEL YS-74LP)  
NSN 4510-01-074-5177  
(YORK-SHIPLEY MODEL 8-SH-76LP)  
NSN 4510-01-080-2402**

TM 10-4510-201-14, 11 January 1972, is changed as follows:

The title is changed to read as shown above.

**NOTE**

*Throughout the manual where the words "Federal Stock Number" (FSN) appears, change to read "National Stock Number" (NSN).*

**By Order of the Secretary of the Army:**

**E. C. MEYER**  
*General, United States Army*  
*Chief of Staff*

**Official:**

**ROBERT M. JOYCE**  
*Brigadier General, United States Army*  
*The Adjutant General*

**DISTRIBUTION:**

**To be distributed in accordance with DA Form 12-25A, Operator maintenance requirements for shower and bath.**

Change  
NO. 5

HEADQUARTERS  
DEPARTMENT OF THE ARMY  
WASHINGTON, D C, 20 January 1978

Operator, Organizational, Direct Support  
and General Support Maintenance Manual

BATH UNIT, PORTABLE, 8-SHOWER HEAD, M1968  
(ORR & SEMBOWER MODEL 8-SH-1, ARMY MODEL SPE35)  
NSN 4510-00-859-8943  
(YORK-SHIPLEY MODEL 8-SH-60, ARMY MODEL SPE35)  
NSN 4510-00-806-9555  
(YORK-SHIPLEY MODEL 8-SH-62, ARMY MODEL SPE41)  
NSN 4510-00-856-8610  
(YORK-SHIPLEY MODEL 8-SH-62, ARMY MODEL SPE44)  
NSN 4510-00-994-9955  
(YORK-SHIPLEY MODEL YS49279)  
NSN 4510-00-168-1930  
(YORK-SHIPLEY MODEL 8-SH-70-YS, ARMY MODEL SPE45)  
NSN 4510-00-418-4774  
(YORK-SHIPLEY MODEL YS74)  
NSN 4510-01-003-0350

TM 10-4510-201-14, 11 January 1972, is changed as follows:

Page ii. The appendixes in the table of contents are superseded as follows:

APPENDIX	A.	REFERENCES
	B.	COMPONENTS OF END ITEM LIST
	C.	ADDITIONAL AUTHORIZATION LIST (NOT APPLICABLE)
	D.	MAINTENANCE ALLOCATION CHART
	E.	EXPENDABLE SUPPLIES AND MATERIAL LIST

Page 1-1. Paragraph 1-3 is rescinded.

Page 3-1. Section I, change "Basic Issue Items List, Appendix C" to read "Basic Issue Items List, Section III, Appendix B".

Page 4-2. Paragraph 4-6, line 3, change "Appendix C" to read "Appendix B".

Page 5-1. Paragraph 5-1, line 3 change "Appendix C" to read "Appendix B".

Page B-1. Change "Appendix B Maintenance Allocation Chart" to read "Appendix D Maintenance Allocation Chart".

Page B-1. Preceding Appendix D add the new Appendix B as follows:

## APPENDIX B COMPONENTS OF END ITEMS LIST

### Section I. INTRODUCTION

#### B-1. Scope

This appendix lists integral components of and basic issue items for the bath unit to help you inventory items required for safe and efficient operation.

#### B-2. General

The Components of End Item List is divided into the following sections:



**a. Section II. Integral Components of the End Item.** These items, when assembled, comprise the bath unit and must accompany it whenever it is transferred or turned in. These illustrations will help you identify these items.

**b Section III. Basic Issue Items.** These are minimum essential items required to place the bath unit in operation, to operate it, and must accompany the bath unit during operation and whenever it is transferred between accountable officers. The illustrations will assist you with hard-to-identify items. This manual is your authority to requisition replacement BII, based on Table(s) of Organization and Equipment (TOE)/Modification Table of Organization and Equipment (MTOE) authorization of the end item.

### B-3. Explanation of Columns

**a. Illustration.** This column is divided as follows:

(1) **Figure Number.** Indicates the figure number of the illustration on which the item is shown (if applicable).

(2) **Item Number.** The number used to identify item called out in the illustration.

**b. National Stock Number (NSN).** Indicates the National stock number assigned to the item and which will be used for requisitioning.

**c. Part Number (P/N).** Indicates the primary number used by the manufacturer, which controls the design and characteristics of the item by means of its engineering drawings, specifications, stan-

dards, and inspection requirements to identify an item or range of items.

**d. Description.** Indicates the Federal item name and, if required, a minimum description to identify the item.

**e. Location.** The physical location of each item listed is given in this column. The lists are designed to inventory all items in one area of the major item before moving on to an adjacent area.

**f. Usable on Code.** "USABLE ON" codes are included to help you identify which component items are used on the different models. Identification of the codes used in these lists are:

CODE	USED ON
BUG	Model 8-SH-1
BUH	Model 8-SH-60
BUJ	Model 8-SH-62
BUK	Model 8-SH-63
BUL	Model YS49279
BUM	Model 8-SH-70YS
CJK	Model YS-74

#### NOTE

When the column is blank the item required is applicable to all items.

**g. Quantity Required (Qty Reqd).** This column lists the quantity of each item required for a complete major item.

**h. Quantity.** This column is left blank for use during inventory. Under the Rcv'd column, list the quantity you actually receive on your major item. The Date columns are for use when you inventory the major item at a later date; such as for shipment to another site.

Section II. INTEGRAL COMPONENTS OF END ITEM

(1) ILLUSTRATION		(2) NATIONAL STOCK NO.	(3) PART NO. & FCN	(4) DESCRIPTION	(5) LOCATION	(6) USABLE ON CODE	(7) QTY REQD	(8) QUANTITY		
(a) FIGURE NO.	(b) ITEM NO.							RCVD	DATE	DATE
				Generator Receptacle Box, with Cable Assy, consisting of the following items:			1			
4-3	6	6145-00-548-1243	67276 (79466)	Cable, Power Elec- trical 24" Required			1			
4-3	3	5975-00-840-5844	67230 (79466)	Cover, Conduit Outlet			2			
4-3	5	5935-00-836-3605	7410G (74545)	Connector, Receptacle			2			
4-3	2	5975-00-711-1868	67323 (79466)	Condulet: 2 Gang			1			
		5975-00-836-8369	100457 (79466)	Connector, Electrical			1			
				Cable, Generator to water heater & Pump; Consisting of the following items:			2			
4-18	1	5935-00-581-4099	7411G (74545)	Connector, Power Cord, 4 Wire			2			
4-16	5	5935-00-284-3366	7541 (74545)	Cover, Electrical Conduit, Rubber, 4 Wire			4			
4-18	1	5935-00-981-8078	7413G (74545)	Connector, Plug, Elec, 4 Wire, Power Cord			2			
4-18	4	6145-00-519-2821	JC580 (81348)	Cable, Power, Elec, 25 ft, required for each cable			2			
1-1	10.	4730-00-707-9626	47418 (79466)	Strainer: Water Pump Suction Hose			1			
1-1	8	4730-00-707-1106	47348 (79466)	Hose Assy: Water Pump Suction			1			
1-1	5&9	4730-00-963-6744	47549 (79466)	Hose Assy: Shower Stand and Water Pump			2			
2-8	6	4520-00-960-6357	90329 (79466)	Pipe, Air Conditioning Water Heater Exhaust			1			

Section II. INTEGRAL COMPONENTS OF END ITEM (Cont'd)

(1) ILLUSTRATION		(2) NATIONAL STOCK NO.	(3) PART NO. & FCNM	(4) DESCRIPTION	(5) LOCATION	(6) USABLE ON CODE	(7) QTY REQD	(8) QUANTITY			
(a) FIGURE NO.	(b) ITEM NO.							RCV'D	DATE	DATE	DATE
1-1	7	4510-00-707-8971	81-1-2EE3-4 (25567)	Pump Assy Water		BUG BUJ BUK BUL BUM CJK	1				
1-1	7	4320-00-445-9916	67750 (79466)	Pump Assy Water		BUH	1				
4-20	4	4720-00-708-8047	47888 (79466)	Hose Assy: Water Heater Fuel Feed and Return w/Plug Assy, Fuel Tank		BUG BUJ BUL BUK BUM CJK	2				
4-20	1.2, 3.5	4530-01-042-9118	47889A (79466)	Plug Assy, Fuel Tank		BUG BUJ BUJ BUL BUK BUM CJK	1				
1-1	6	4510-00-042-9117	47550 (79466)	Stand Assy, Shower			2				
1-1	1	6115-00-017-8237	SP3.0-MD (07860)	Generator Set, Gasoline Engine, 3KW, AC, 60 HZ, SF 3.0 MD with Canvas Cover			1				

Section III. BASIC ISSUE ITEMS

(1) ILLUSTRATION		(2) NATIONAL STOCK NO.	(3) PART NO. & FCNM	(4) DESCRIPTION	(5) LOCATION	(6) USABLE ON CODE	(7) QTY REQD	(8) QUANTITY			
(a) FIGURE NO.	(b) ITEM NO.							RCV'D	DATE	DATE	DATE
4	2-5	4210-00-270-4512	N-752366 (999539)	Extinguisher, Fire, Carbon Dioxide: Hand Type; Charged, 5 lb cap			1				
				TM 10-4510-201-14		BUG BUH BUJ	1				
				TM 5-6115-271-14		BUK BUL BUM CJK	1				
				TM 5-2803-14			1				

Page C-1. Appendix C is rescinded.  
C-1. Following Appendix D, Appendix E is added  
as follows:

## APPENDIX E EXPENDABLE SUPPLIES AND MATERIALS LIST

### Section I. INTRODUCTION

#### E-1. Scope

This appendix lists expendable supplies and materials you will need to operate and maintain the bath unit. These items are authorized to you by CTA50-970, Expendable Items (except Medical, Class V, Repair Parts, and Heraldic Items).

*a. Column 1 - Item Number.* This number is assigned to the entry in the listing and is referenced in the narrative instructions to identify the material (e.g., "Use cleaning compound, Item 5, App. E").

*b. Column 2 - Level.* This column identifies the lowest level of maintenance that requires the listed item.

C - Operator/Crew

*c. Column 3 - National Stock Number.* This is the National stock number assigned to the item; use it to request or requisition the item.

*d. Column 4 - Description.* Indicates the Federal item name and, if required, a description to identify the item. The last line for each item indicates the part number followed by the Federal Supply Code for Manufacturer (FSCM) in parenthesis, if applicable.

*e. Column 5 - Unit of Measure (U/M).* Indicates the measure used in performing the actual maintenance function. This measure is expressed by a two-character alphabetical abbreviation (e.g., ea, in, pr). If the unit of measure differs from the unit of issue, requisition the lowest unit of issue that will satisfy your requirements.

### Section II. EXPENDABLE SUPPLIES AND MATERIALS LIST

(1) ITEM NUMBER	(2) LEVEL	(3) NATIONAL STOCK NUMBER	(4) DESCRIPTION	(5) U/M
1	C	9130-00-221-0680	Fuel, Gasoline: Bulk as follows: Automotive Combat 91A.	dr
2	C	9150-00-265-9433	Oil, Lubricating OE 30	qt
3	C	9150-00-265-9425	Oil, Lubricating OE 10	qt

By Order of the Secretary of the Army:

**BERNARD W. ROGERS**  
*General, United States Army*  
*Chief of Staff*

Official:

**J. C. PENNINGTON**  
*Brigadier General, United States Army*  
*The Adjutant General*

**Distribution:**

To be distributed in accordance with DA Form 12-25A, organizational maintenance requirements for Shop Equipment Sets, Maintenance: Shower and Bath.

CHANGE }  
No. 4 }

HEADQUARTERS  
DEPARTMENT OF THE ARMY  
WASHINGTON, DC, 28 June 1976

**Operator's, Organizational, Direct Support,  
and General Support Maintenance Manual**

**BATH UNIT, PORTABLE, 8-SHOWER HEAD, M1958  
(ORR & SEMBOWER MODEL 8-SH-1, ARMY MODEL SPE35)  
NSN 4510-00-679-6943  
(YORK-SHIPLEY MODEL 8-SH-60, ARMY MODEL SPE35A)  
NSN 4510-00-806-9555  
(YORK-SHIPLEY MODEL 8-SH-62, ARMY MODEL SPE41)  
NSN 4510-00-856-8610  
(YORK-SHIPLEY MODEL 8-SH-63, ARMY MODEL SPE44)  
NSN 4510-00-994-9955  
(YORK-SHIPLEY MODEL YS49279)  
NSN 4510-00-168-1930  
(YORK-SHIPLEY MODEL 8-SH-70-YS, ARMY MODEL SPE45)  
NSN 4510-00-418-4774  
(YORK-SHIPLEY MODEL YS74)  
NSN 4510-01-003-0350**

**REPORTING OF ERRORS**

You can improve this manual by recommending improvements using DA Form 2028 (Recommended Changes to Publications and Blank Forms) or DA Form 2028-2 (Test) included in this change and mail the form direct to Commander, US Army Troop Support Command, ATTN: DRSTS-MPP, 4300 Goodfellow Blvd., St. Louis, MO 63120. A reply will be furnished direct to you.

TM 10-4510-201-14, 11 January 1972, is changed as follows:  
The title is changed to read as shown above.

By Order of the Secretary of the Army:

**FRED C. WEYAND**  
*General, United States Army*  
*Chief of Staff*

Official:

**PAUL T. SMITH**  
*Major General, United States Army*  
*The Adjutant General*

Distribution:

To be distributed in accordance with DA Form 12-25A (qty rqr block No. 170), organizational maintenance requirements for shower and bath.



Change }  
No. 3 }

HEADQUARTERS  
DEPARTMENT OF THE ARMY  
Washington, D. C., 19 June 1974

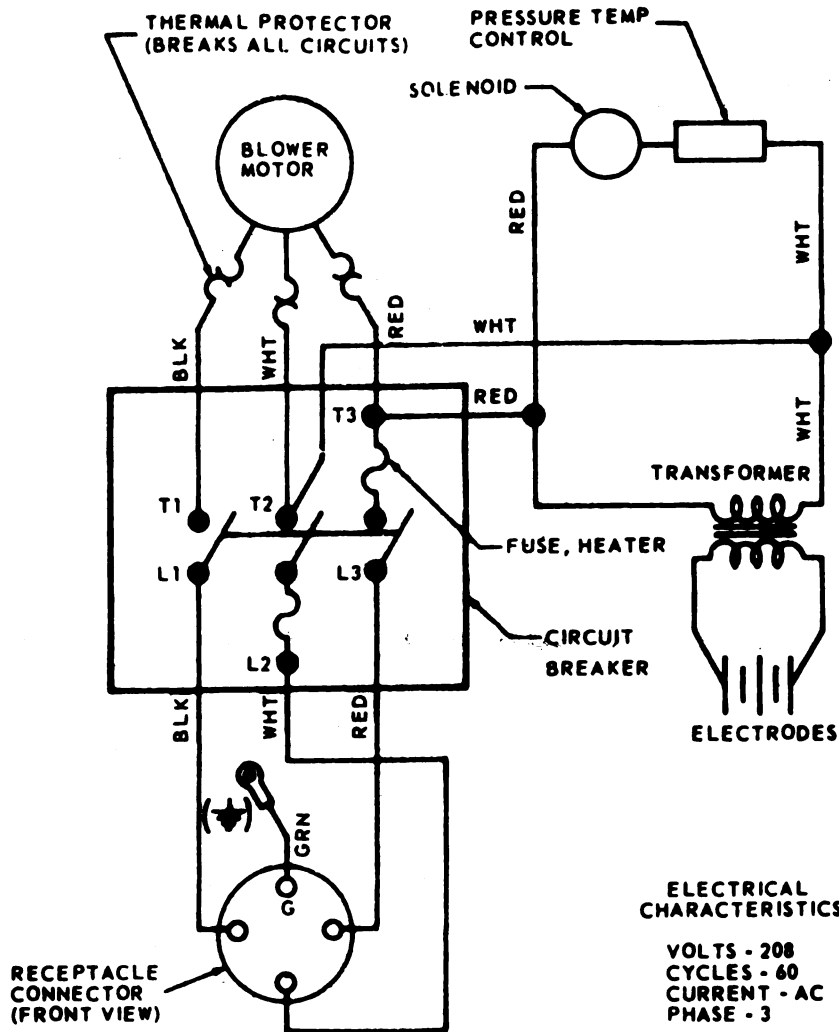
**Operator, Organizational, Direct Support  
and General Support Maintenance Manual  
BATH UNIT PORTABLE, 8-SHOWER HEAD, M1958  
ORR AND SEMBOWER MODEL 8-SH-1, ARMY  
MODEL SPE 35, FSN 4510-670-6943  
YORK-SHIPLEY MODEL 8-SH-60, ARMY MODEL  
SPE-35A FSN 4510-806-9555  
YORK-SHIPLEY MODEL 8-SH-62, ARMY MODEL  
SPE-41, FSN 4510-856-8610  
YORK-SHIPLEY MODEL 8-SH-63 ARMY MODEL  
SPE-44, FSN 4510-994-9955  
YORK-SHIPLEY MODEL YS49279  
FSN 4510-168-1930  
YORK-SHIPLEY MODEL 8-SH-70 YS, ARMY MODEL  
SPE-45, FSN 4510-418-4774**

TM 10-4510-201-14, 11 January 1972, is changed as follows:  
Cover Page. Add the following warning on the inside of the cover page.

**WARNING  
FIRE HAZARD**

Dry cleaning solvent, P-D-680, used to clean parts is potentially dangerous to personnel and property. Do not use near open flame or excessive heat. Flash point of solvent is 100° F - 128° F.  
Page 4-39. Figure 4-28 is superseded as follows:





ME 4510-201-14/4-23 C3

Figure 4-23. Wiring diagram for water heater.

Page 4-57. Paragraph 4-43.1 is added after paragraph 4-43 as follows:

**4-43.1. Thermal Protector, Blower and Fuel Pump Motor.** a. The blower and fuel pump electric motor equipped with a thermal protector device will, in case of a bind or short circuit, react by opening the circuit to the motor in less than 20 seconds. When this condition occurs, a hum from the motor will be audible as the temperature of the motor rises to the extent that it is warm. After activation of the thermal protector, it will be necessary to wait for the motor to cool before the thermal protector can be reset. The reset button is located on the bell end of the motor; to reset, depress the button.

b. If the motor is not turning and is activating the thermal protector, proceed as follows:

(1) Shut off the electrical power, open the blower air gate and, with screwdriver inserted through the air gate opening, try to rotate the motor.

(2) If unable to free the motor as in step (1) above, it may be necessary to remove the fuel pump. With the fuel pump coupling disconnected, attempt to run the motor to determine whether the pump or the motor is bound. If the pump is bound, fill the housing with lubricant and attempt to turn the shaft with a wrench. Failure to free the motor will require disassembly of the pump or motor to determine the cause of the defect.

**By Order of the Secretary of the Army:**

**Official:**

**VERN: L. BOWERS**  
*Major General, United States Army*  
*The Adjutant General*

**CREIGHTON W. ABRAMS**  
*General, United States Army*  
*Chief of Staff*

**Distribution:**

To be distributed in accordance with DA Form 13-55A (qty per block No. 170), Organizational maintenance requirements for Shower and Bath Equipment.



CHANGE }  
No. 2 }

HEADQUARTERS  
DEPARTMENT OF THE ARMY  
WASHINGTON, D.C., 12 February 1974

**Operator, Organizational, Direct Support,  
and General Support Maintenance Manual  
BATH UNIT, PORTABLE, 8-SHOWER HEAD, M1958  
ORR AND SEMBOWER MODEL 8-SH-1, ARMY MODEL  
SPE 35 FSN 4510-679-6493  
YORK-SHIPLEY MODEL 8-SH-60, ARMY MODEL  
SPE 35A, FSN 4510-806-9555  
YORK-SHIPLEY MODEL 8-SH-62, ARMY MODEL  
SPE 41, FSN 4510-856-8610  
YORK-SHIPLEY MODEL 8-SH-63, ARMY MODEL  
SPE 44, FSN 4510-994-9955  
YORK-SHIPLEY MODEL YS49279  
FSN 4510-168-1930  
YORK-SHIPLEY MODEL 8-SH-70 YS, ARMY MODEL  
SPE 45, FSN 4518-418-4774**

TM 10-4510-201-14, 11 January 1972, is changed as follows:

*Page iii.* Add the following below figure 3-5:

*Figure 3-5.1.* Replacement shower head nozzle for Army models SPE 41, 44, and 45 and for York-Shipley Model YS49279.

*Page 1-1.* Paragraph 1-3 is superseded as follows:

### **1-3. Reporting of Equipment Publication Improvements**

The reporting of errors, omissions, and recommendations for improving this publication by the individual user is encouraged. Reports should be submitted on DA Form 2028 (Recommended Changes to Publications) and forwarded direct to Commander, US Army Troop Support Command, ATTN: AMSTS-MP, 4300 Goodfellow Boulevard, St. Louis, MO 63120.

*Page 3-7.* In paragraph 3-10a, line 2, change "(fig. 3-4 or 3-5)" to read "(fig. 3-4, 3-5, or 3-5.1)."

Add paragraph 3-10b(3) after paragraph 3-10b(2) as follows:

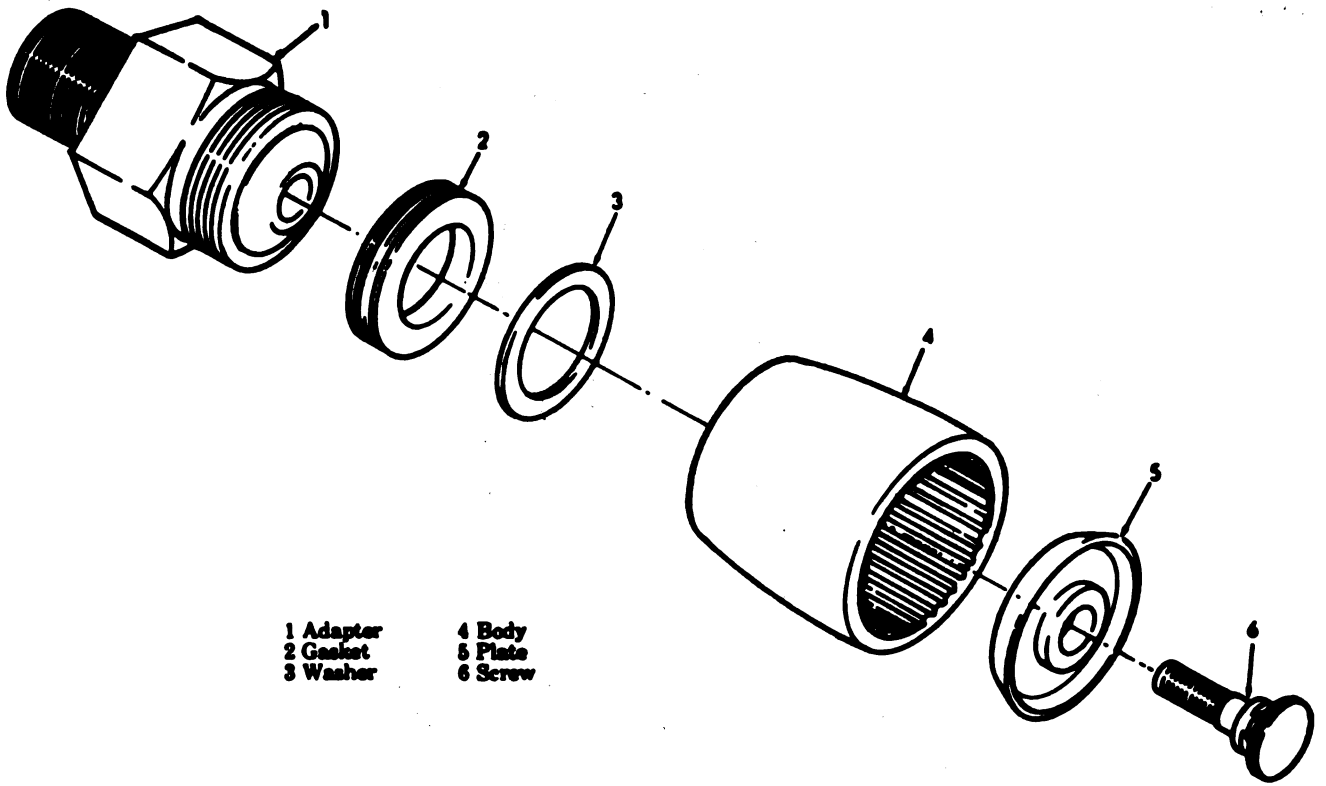
(3) Clean the nozzle body (fig. 3-5.1) used as the replacement shower head for Army models SPE-41, 44, and 45 and for the York-Shipley Model YS49279.

(a). Unscrew and remove the nozzle body (4) from the adapter (1); loosen the thumb screw (6) in the center of the body.

(b). Clean all dirt and grit from the nozzle body.

(c). Reassemble the nozzle by screwing the nozzle body (4) to the adapter (1), and tightening the thumb screw (6) in the center of the body. Make sure the nozzle body threads are not crossed on the adapter. Hand tighten the nozzle body securely.

*Page 3-9.* Figure 3-5.1 added after figure 3-5 as follows:

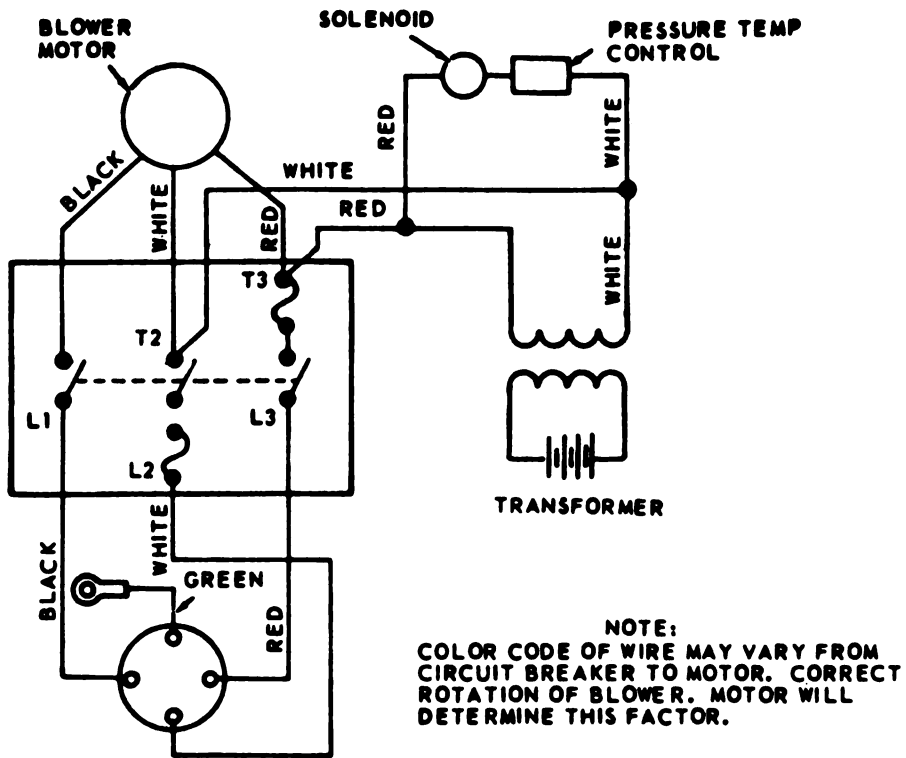


- |           |         |
|-----------|---------|
| 1 Adapter | 4 Body  |
| 2 Gasket  | 5 Plate |
| 3 Washer  | 6 Screw |

ME 4510-201-14/3-5.1 C2

**Figure 3-5.1. Replacement shower head nozzle for Army models SPE 41, 44, and 45 and for York-Shipley Model YS48879.**

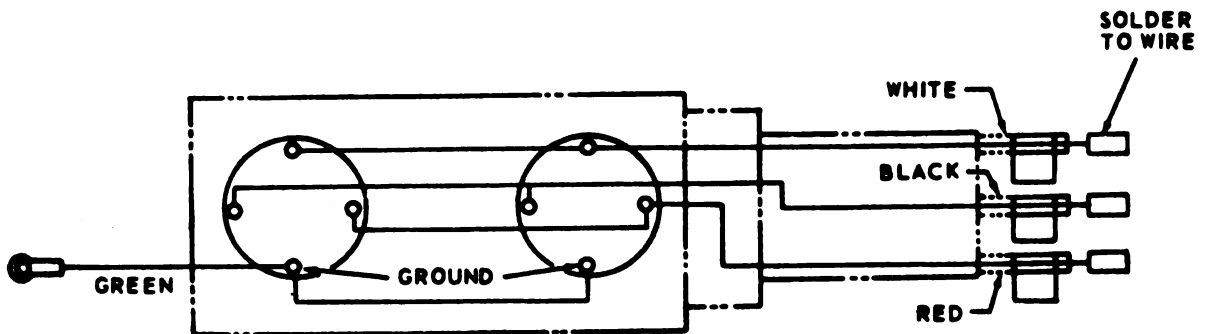
Page 4-9. Figure 4-4 is superseded as follows:



ME 4510-201-14/4-4 C2

Figure 4-4. Wiring diagram for generator receptacle box.

Page 4-30. Figure 4-23 is superseded as follows:



ME 4510-201-14/4-23 C2

Figure 4-23. Wiring diagram for water heater.

**By Order of the Secretary of the Army:**

**CREIGHTON W. ABRAMS**  
*General, United States Army*  
*Chief of Staff*

**Official:**

**VERNE L. BOWERS**

*Major General, United States Army*

*The Adjutant General*

**Distribution:**

To be distributed in accordance with DA Form 13-25A, (qty rqr block No. 170) Organizational Maintenance Requirements for Shower and Bath.

HEADQUARTERS  
DEPARTMENT OF THE ARMY  
Washington, D.C. 7 July 1972

Change }  
No. 1 }

**Operator, Organizational, Direct Support and General  
Support Maintenance Manual  
BATH UNIT, PORTABLE, 8-SHOWER HEAD, M1958 ORR  
AND SEMBOWER MODEL 8-SH-1, ARMY MODEL SPE 35,  
FSN 4510-679-6493  
YORK-SHIPLEY MODEL 8-SH-60, ARMY MODEL SPE-35A,  
FSN 4510-806-9555  
YORK-SHIPLEY MODEL 8-SH-62, ARMY MODEL SPE 41  
FSN 4510-856-8610  
YORK-SHIPLEY MODEL 8-SH-63, ARMY MODEL SPE 44,  
FSN 4510-994-9955  
YORK-SHIPLEY MODEL YS 40279,  
FSN 4510-169-1990  
YORK-SHIPLEY MODEL 8-SH-70 YS, ARMY MODEL SPE 45,  
FSN 4510-418-4774**

TM 10-4510-201-14, 11 January 1972, is changed  
as follows:  
Page ii. Change title of Appendix C as follows:

APPENDIX C. BASIC ISSUE ITEMS LIST AND  
ITEMS TROOP INSTALLED OR AUTHORIZED  
Page C-1. Appendix C is superseded as follows:

## APPENDIX C BASIC ISSUE ITEM LIST AND ITEMS TROOP INSTALLED OR AUTHORIZED

### Section I. INTRODUCTION

#### 1. Scope

This appendix lists basic issue items, items troop installed or authorized which accompany the bath unit and required by the crew/operator for operation, installation, or operator's maintenance.

#### 2. General

This basic issue items, items troop installed or authorized list is divided into the following sections:

a. *Basic Issue Items List—Section II.* "Not Applicable".

b. *Items Troop Installed or Authorized List—Section III.* A list, in alphabetical sequence of items which at the discretion of the unit commander may accompany the end item, but are NOT subject to be turned in with the end item.

#### 3. Explanation of Columns

The following provides an explanation of columns in the tabular list of Basic Issue Items List, Section II, and Items Troop Installed or Authorized, Section III.

a. *Source, Maintenance, and Recoverability Code(s) (SMR):*

(1) Source code, indicates the source for the listed items. Source code is:

Code

Explanation

P

Repair parts, special tools and test equipment supplied from GSA/DBA or Army supply system and authorized for use at indicated maintenance levels.

(2) Maintenance code, indicates the lowest level of maintenance authorized to install the listed item.



**The maintenance level code is:**

Code Explanation

C ..... Crew/Operator

(3) Recoverability code, indicates whether un-serviceable items should be returned for recovery or salvage. Items not coded are non-recoverable. Recoverability codes are:

Code Explanation

R Applied to repair parts (assemblies and components), special tools and test equipment which are considered economically repairable at direct and general support maintenance levels.

S Repair parts, special tools, test equipment and assemblies which are economically repairable at DSU and GSU activities and which normally are furnished by supply on an exchange basis.

b. Federal Stock Number. This column indicates the federal stock number assigned to the item and will be used for requisitioning purposes.

c. Description. This column indicates the Federal item name and any additional description of the item required.

d. Unit of Measure (U/M). A 2 character alphabetic abbreviation indicating the amount or quantity of the item upon which the allowances are based, e.g. ft, ea, pr, etc.

e. Quantity Furnished With Equipment (BILL only). This column indicates the quantity of an item furnished with the equipment.

f. Quantity Authorized (Items Troop Installed or Authorized Only). This column indicates the quantity of the item authorized to be used with the equipment.

g. Illustration (BILL only). This column is divided as follows:

(1) Figure Number. Indicates the figure number of the illustration in which the item is shown.

(2) Item number. Indicates the callout number used to reference the item in the illustration.

**Section III. ITEMS TROOP INSTALLED OR AUTHORIZED LIST**

(1) SBR code	(2) Federal stock number	(3) Description  Ref. No. & Mtr code	(4) Unit of meas	(5) Qty auth
PC	7530-550-0618	CASE, MAINTENANCE AND OPERATIONAL MANUA.	EA	1

By Order of the Secretary of the Army:

**BRUCE PALMER, JR**  
General, U. S. Army  
Acting Chief of Staff

Official:

**VERNE L. BOWERS**  
Major General, United States Army  
The Adjutant General

**Distribution:**

To be distributed in accordance with DA Form 12-25A (qty req block No 170) Organizational Maintenance requirements for Shower and Bath.

TECHNICAL MANUAL }  
 No. 10-4510-201-14 }

HEADQUARTERS  
 DEPARTMENT OF THE ARMY  
 WASHINGTON, D. C., 11 January 1971

**OPERATOR, ORGANIZATIONAL, DIRECT SUPPORT AND  
 GENERAL SUPPORT MAINTENANCE MANUAL**

**BATH UNIT, PORTABLE, 8-SHOWER HEAD, M1958  
 ORR & SEMBOWER MODEL 8-SH-1  
 ARMY MODEL SPE 35, FSN 4510-679-6493  
 YORK-SHIPLEY MODEL 8-SH-60,  
 ARMY MODEL SPE-35A, FSN 4510-806-9555  
 YORK-SHIPLEY MODEL 8-SH-62,  
 ARMY MODEL SPE-41, FSN 4510-856-8610  
 YORK-SHIPLEY MODEL 8-SH-63,  
 ARMY MODEL SPE 44, FSN 4510-994-9955  
 YORK-SHIPLEY MODEL YS49279, FSN 4510-168-1930  
 YORK-SHIPLEY MODEL 8-SH-70YS,  
 ARMY MODEL SPE 45, FSN 4510-418-4774**

		Paragraph	Page
CHAPTER Section	1. INTRODUCTION		
	I. General .....	1-1-1-3	1-1
	II. Description and data .....	1-4-1-6	1-1
CHAPTER Section	2. OPERATING INSTRUCTIONS		
	I. Service upon receipt of bath unit .....	2-1,2-2	2-1
	II. Movement to a new worksite .....	2-3,2-4	2-12
	III. Controls and instruments .....	2-5-2-7	2-12
	IV. Operation under usual conditions .....	2-8-2-12	2-18
	V. Operation under unusual conditions .....	2-13-2-15	2-22
	VI. Operation of material used in conjunction with the equipment .....	2-16-2-17	2-22
CHAPTER Section	3. OPERATOR'S MAINTENANCE INSTRUCTIONS		
	I. Basic issue items		
	II. Lubrication instructions		
	III. Operator preventive maintenance checks and services .....	3-1,3-2	3-1
	IV. Operator troubleshooting .....	3-3,3-4	3-3
	V. Maintenance of miscellaneous items .....	3-5-3-8	3-4
	VI. Maintenance of shower stand and water pump .....	3-9-3-11	3-7
CHAPTER Section	4. ORGANIZATIONAL MAINTENANCE INSTRUCTIONS		
	I. Service upon receipt of bath unit .....	4-1-4-5	4-1
	II. Repair parts, special tools and equipment .....	4-6-4-8	4-2
	III. Organizational preventive maintenance checks and services .....	4-9,4-10	4-3
	IV. Troubleshooting .....	4-11,4-12	4-5
	V. Maintenance of miscellaneous items .....	4-13-4-18	4-7
	VI. Maintenance of shower stand assembly .....	4-19-4-21	4-12
	VII. Maintenance of water pump assembly .....	4-22-4-27	4-14
	VIII. Maintenance of water heater assembly .....	4-28-4-45	4-25

\* This TM supersedes TM 10-4510-201-10, 14 January 1965, TM 10-4510-201-20, 16 August 1965, TM 10-4510-201-35, 5 February 1965, including all changes.

		Paragraph	Page
CHAPTER	5. DIRECT SUPPORT AND GENERAL SUPPORT MAINTENANCE INSTRUCTIONS		
Section	I. Repair parts, special tools and equipment .....	5-1—5-3	5-1
	II. Direct support and general support troubleshooting .....	5-4,5-5	5-1
	III. General maintenance instructions .....	5-6—5-9	5-1
CHAPTER	6. REPAIR OF MISCELLANEOUS ITEMS, SHOWER STAND AND PUMP ASSEMBLY, AND WATER HEATER ASSEMBLY		
Section	I. Miscellaneous items .....	6-1,6-2	6-1
	II. Shower stand and pump assembly .....	6-3—6-6	6-3
	III. Water heater assembly .....	6-7—6-14	6-3
CHAPTER	7. ADMINISTRATIVE STORAGE .....	7-1 — 7-2	7-1
APPENDIX	A. REFERENCES .....	A-1—A-6	A-1
	B. MAINTENANCE ALLOCATION CHART .....	B-1—B-4	B-1
	C. BASIC ISSUE ITEMS .....	C-1—C-3	C-1
INDEX	.....		I-1

# LIST OF ILLUSTRATIONS

<i>Figure</i>	<i>Title</i>	<i>Page</i>
1-1	Bath unit set up for operation. ....	1-2
1-2	Bath unit instruction plate on tank. ....	1-4
1-3	Bath unit data plate. ....	1-4
2-1	Operational layout for bath unit. ....	2-1
2-2	Removing suction hose strainer from exhaust duct. ....	2-3
2-3	Removing shower stand legs from exhaust duct. ....	2-4
2-4	Suction hose assembly and shower stand risers on baseboard. ....	2-5
2-5	Baseboard brackets retaining. ....	2-6
2-6	Methods of positioning strainer in water source. ....	2-7
2-7	Water pump with hose assemblies and cables connected. ....	2-8
2-8	Hoses connected to water heater and fuel drum. ....	2-9
2-9	Hoses connected to heater manifold. ....	2-10
2-10	Connecting water hose assembly to shower stand adapter. ....	2-11
2-11A	Bath unit controls and instruments (sheet 1 of 5). ....	2-14
2-11B	Bath unit controls and instruments (sheet 2 of 5). ....	2-15
2-11C	Bath unit controls and instruments (sheet 3 of 5). ....	2-16
2-11D	Bath unit controls and instruments (sheet 4 of 5). ....	2-17
2-11E	Bath unit controls and instruments (sheet 5 of 5). ....	2-18
2-12	Water pump assembly. ....	2-19
2-13	Water heater, left end view. ....	2-21
3-1	Suction strainer. ....	3-5
3-2	Suction hose assembly. ....	3-6
3-3	Shower stand and pump hoses. ....	3-6
3-4	Shower head nozzle (used on Army Models SPE 35 and 35A), disassembled. ....	3-8
3-5	Shower head nozzle (used on Army Models SPE 41, SPE 44, York-Shipley Model YS49279 and Army Model SPE 45). ....	3-9
3-6	Water line strainer. ....	3-10
4-1	Bath unit with top and sides of crate removed. ....	4-1
4-2	Hose assemblies mounted on water heater and baseboard. ....	4-2
4-3	Generator receptacle box with cable. ....	4-8
4-4	Wiring diagram of generator receptacle box. ....	4-9
4-5	Bath unit baseboard and straps. ....	4-11
4-6	Burner exhaust duct. ....	4-12
4-7	Shower stand riser. ....	4-13
4-8	Shower stand flow control valve (used only on Army Models SPE 41, 44, 45 and York-Shipley Model YS49279). ....	4-14
4-9	Strainer element, removed from water line strainer. ....	4-15
4-10	Water pump assembly, left side view. ....	4-16
4-11	Water pump electrical connections. ....	4-17
4-12	Pump housing removed from bracket and motor. ....	4-18
4-13	Vane plate mounted on pump bracket. ....	4-19
4-14	Water pump disassembled. ....	4-20
4-15	Wiring diagram for water pump. ....	4-21
4-16	Circuit breaker subassembly showing wire connections. ....	4-23
4-17	Circuit breaker subassembly cover opened to show overload heaters. ....	4-24
4-18	Wiring diagram of power cord cable. ....	4-25
4-19	Schematic drawing of burner fuel system. ....	4-26
4-20	Barrel plug and fuel hose assemblies. ....	4-27
4-21	Water heater, bottom view. ....	4-28
4-22	Water heater control box and gages. ....	4-29
4-23	Wiring diagram for water heater. ....	4-30
4-24	Water heater skid and skid level. ....	4-31
4-25	Boiler box cover and gasket, removal and installation. ....	4-32
4-26	Water heater, left end view. ....	4-35
4-27	Electrodes and holder, removed from burner assembly. ....	4-36
4-28	Burner fuel nozzle, disassembled. ....	4-36
4-29	Burner head removed from water heater. ....	4-37
4-30	Burner electrode spark gap adjustment. ....	4-38
4-31	Upper manifold relief valve (Army Models SPE 41, SPE 44, SPE 45 and York-Shipley Model YS49279). ....	4-39
4-32	Water heater pressure and temperature control with cover removed. ....	4-40
4-33	Water heater upper manifold. ....	4-41
4-34	Shower stand control and water blender valves. ....	4-42
4-35	Schematic drawing showing inside of water heater tank. ....	4-43

<i>Figure</i>	<i>Title</i>	<i>Page</i>
4-36	Water heater control panel box with cover removed. ....	4-45
4-37	Installation of York-Shipley pressure and temperature control. ....	4-47
4-38	Fuel pump and filter mounted on blower. ....	4-50
4-39	Adjusting pressure on fuel pump. ....	4-51
4-40	Fuel pump, strainer removed. ....	4-53
4-41	Filter head, removing fuel filter head gasket. ....	4-54
4-42	Blower, disassembled. ....	4-55
4-43	Blower shutter (used on Army Models SPE 44 and SPE 45 and York-Shipley Model YS49279). ....	4-56
6-1	Fabrication details for baseboard. ....	6-2
6-2	Schematic drawing of test procedures for transformer. ....	6-4
6-3A	Pressure and temperature control (Used on all Army Models except SPE 45) (sheet 1 of 2). ....	6-6
6-3B	Pressure and temperature control (Used on all Army Models except SPE 45) (sheet 2 of 2). ....	6-7
6-4	Pressure and temperature control (Used on Army Model SPE 45). ....	6-8
6-5	Altitude variations graph. ....	6-9
6-6	Fuel pump, disassembled. ....	6-10
6-7	Water heater blower and fuel pump motor, disassembled. ....	6-12

# CHAPTER 1

## INTRODUCTION

---

### Section I. GENERAL

#### 1-1. Scope

a. This manual contains operating and maintenance instructions for those responsible for the organizational, direct support and general support maintenance of the M1958 8-shower-head, portable, bath unit as allocated by the Maintenance Allocation Chart.

b. Refer to TM 750-244-3 (Procedures for Destruction of Equipment to Prevent Enemy Use).

#### 1-2. Forms and Records

Maintenance forms, records and reports which are to be used by maintenance personnel at all

maintenance levels are listed in and prescribed by TM 38-750, The Army Maintenance Management System (TAMMS).

#### 1-3. Reporting of Errors

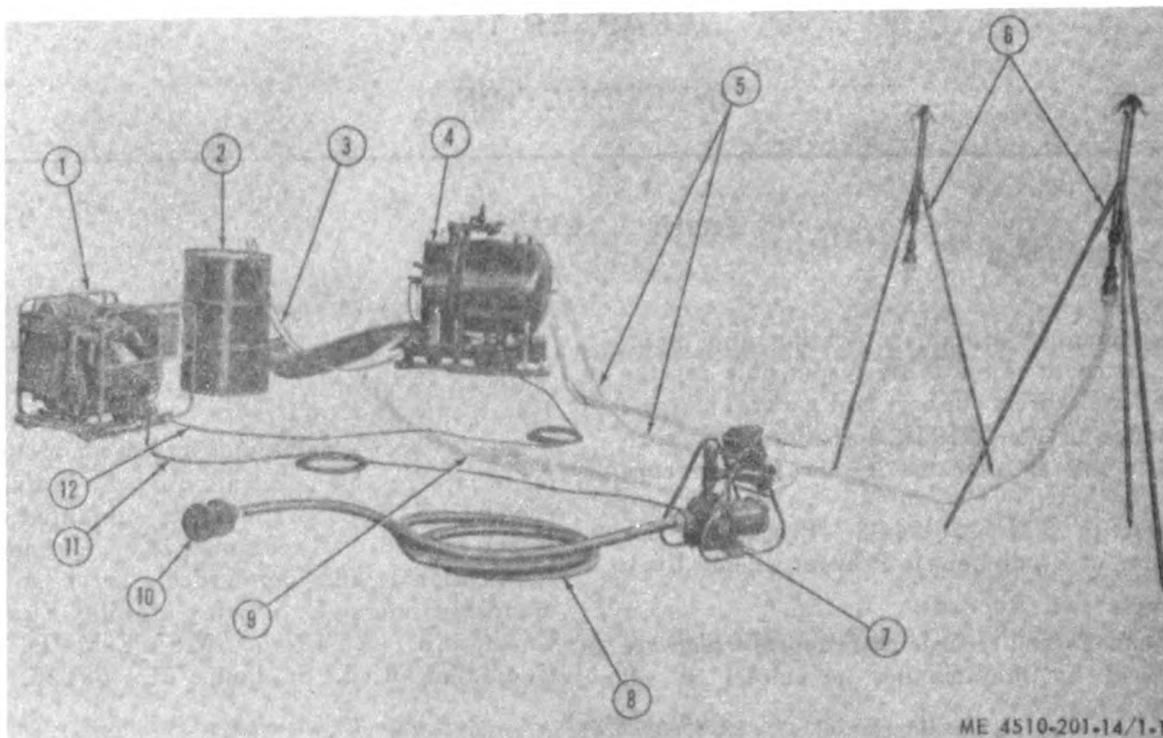
Report of errors, omissions, and recommendations for improving this publication by the individual is encouraged. Reports should be submitted on DA Form 2028 (Recommended Changes to Publications) and forwarded direct to Commanding General, U. S. Army Mobility Equipment Command, ATTN: AMSME-MPP, 4300 Goodfellow Blvd., St. Louis, Mo. 63120.

### Section II. DESCRIPTION AND DATA

#### 1-4. Description

The 8-shower head portable bath unit (fig. 1-1) is a liquid-fuel-fired water heating plant designed to supply warm water to each of the shower nozzles. The bath unit is equipped with the necessary hoses (5, 8 and 9), water heater (4), water pump assembly (7) and shower stands (6) to supply all the warm water needed for operation. The water pump draws water through the suction strainer (10) and the hose from the water source (8) and forces it through the discharge hose (9) to the water heater. The water heater raises the temperature of the incoming water and maintains it at the desired temperature. The heated water is then forced

through the two discharge hoses (5) to the shower stands by the pressure of the incoming water. The electric power to operate the bath unit is supplied by a self-contained portable 3 kw, 60-cycle, 208 volts, 3-phase, skid-mounted generator set (1). For a further description of the generator set, refer to the appropriate technical manual listed in Appendix A. All electrically operated components of bath unit are grounded through a fourth wire incorporated in the power cord cables (11), (12). These cables are connected to the generator outlet box. The outlet box is grounded to the generator frame, and the frame is grounded through a ground rod.



- 1 Set, generator
- 2 Drum, fuel
- 3 Hose assemblies, fuel feed and return
- 4 Heater, water
- 5 Hose assemblies, water heater-to-shower stand

- 6 Stands, shower
- 7 Pump assembly, water
- 8 Hose assembly, suction
- 9 Hose assembly, water pump heater
- 10 Strainer, water pump suction hose
- 11 Cable, generator-to-water pump
- 12 Cable, generator-to-water heater

Figure 1-1. Bath unit set up for operation.

### 1-5. Differences Between Models

This manual covers the Orr & Sembower Model 8-SH-1, Army Model SPE 35; the York-Shipley Model 8-SH-60, Army Model SPE 35A; the York-Shipley Model 8-SH-62, Army Model SPE 41; York-Shipley Model 8-SH-63, Army Model SPE 44, York-Shipley Model YS49279; and York-Shipley Model 8-SH-70YS, Army Model SPE 45. The differences in the models covered in this manual are minor, and where the differences exist, they are indicated in the applicable paragraphs by the particular Army Model Number. The difference in Army Model SPE 45 from previous models is the incorporation of a newly designed pressure and temperature control assembly. Refer to paragraph 6-11.

### 1-6. Identification and Tabulated Data

*a. Identification.* The bath unit has two plates; one instructional plate and one data plate and they are located as follows:

- (1) *End item instruction plate.* The bath unit

instruction plate (fig. 1-2) is located on the side of the water heater tank.

(2) *End item data plate.* The bath unit data plate (fig. 1-3), which identifies the complete end item, is mounted on the lower right end of the water heater.

#### NOTE

Throughout this manual, the use of the terms *right*, *left*, *front* and *rear* for the water heater indicates from the viewpoint of the operator as he operates and faces the burner fuel shutoff valve and the burner fuel control valve. The use of these terms for the water pump also indicates the directions from the viewpoint of the operator as he faces the control panel box.

*b. Tabulated Data.* Certain 3 kw generator sets are matched with specific bath unit models and they are as follows:

#### NOTE

The Hollingsworth and the SZEMCO Model generator sets are being replaced by the Military Design DOD Model MEP-016A.

<i>FSN (Gen.)</i>	<i>Generator Set</i>	<i>Bath Unit Models</i>
6115-649-8916	Generator Set, GED, Skid-Mounted, 3 kw, Hollingsworth Model JHGW3AU	U / With Army Mdl. SPE 35 and SPE 35A
6115-017-8237	Generator Set, GED, Skid-Mounted, 3 kw, Bogue Electric Model SF3.0-MD	U / With Army Mdl. SPE 44, 45, and York-Shibley Mdl. YS49279 (Refer to TM 5-6115-271-Series)
6115-731-8191	Generator Set, GED, Skid-Mounted, 3 kw, SZEMCO Inc. Model 1021	U / With Army Model SPE 41

**(1) Bath unit.**

Weight (crated) ..... 1,260 lb (pounds)  
 Cubage (crated) ..... 88.5 cu. ft. (cubic feet)  
 Dimensions (crated):  
 Length ..... 78 in. (inches)  
 Height ..... 40 in.  
 Width ..... 49 in.

**(2) Water heater.**

Dimensions:  
 Length ..... 3 ft. (feet) 3 in. (inches)  
 Height ..... 3 ft. 2 in.  
 Width ..... 2 ft. 1 in.  
 Weight (approximate) . 350 lb.  
 Capacity (water) ..... 20 gal. (gallons)  
 Fuel (for burner) ..... Gasoline or No. 2 fuel oil  
 Fuel consumption rate 2 to 6.5 gal. per hr. (hour)

**(3) Blower and fuel pump electric motor.**

Type ..... AC, 3-phase  
 Volts ..... 208  
 Cycles ..... 60  
 Horsepower ..... 1 / 3  
 Speed ..... 3,450 rpm (revolution per minute)

**(4) Water pump assembly.**

Type ..... Centrifugal, self-priming (after initial priming)  
 Dimensions:  
 Length ..... 1 ft, 7 1/2 in.  
 Height ..... 1 ft, 9 in.  
 Width ..... 11 in.  
 Weight (approximate) 70 lb.  
 Rate Capacity ..... 18 to 20 gpm (gallons per minute) at 65 foot head  
 Manufacturer:  
 Army Models SPE  
 35, 41 and 44 ... Gorman-Rupp Company

Army Model SPE  
 35A ..... Marlow Pump Division, Bell & Gossett Co.  
 York-Shibley Model  
 YS49279 ..... Gorman-Rupp Co.  
 York-Shibley Model  
 8-SH-70YS Army  
 Mdl. SPE 45 .... Gorman-Rupp Co.

**(5) Water pump electric motor.**

Type ..... AC, 3-phase  
 Volts ..... 208  
 Cycles ..... 60  
 Horsepower ..... 3/4  
 Speed ..... 3,450 rpm

**(6) Fuel Pump.**

Manufacturer ..... Sundstrand  
 Type ..... 1-stage-gear  
 Model number ..... J3CA-178-3  
 Pressure ..... 0 to 150 psi (pounds per square inch)

**(7) Ignition transformer.**

Volts  
 Primary ..... 208  
 Secondary ..... 10,000  
 Cycles ..... 60

**(8) Shower stand.**

Number of stands .... 2  
 Number of nozzles ... 4 per stand  
 Height ..... 6 ft, 5 in.  
 Water discharge ..... 2.25 gpm per nozzle at 15 psi

**(9) Suction hose assembly.**

Number ..... 1  
 Type ..... rubber  
 Length ..... 25 ft.  
 Diameter ..... 1 1/2 in. (id) (inside diameter)

**(10) Water hose assembly.**

Number ..... 3  
 Type ..... Canvas  
 Length ..... 25 ft.  
 Diameter ..... 1 1/2 in. (id)

**(11) Fire extinguisher.**

Type ..... Carbon dioxide  
 Capacity ..... 5 lb.  
 Weight (empty) ..... 10 7 / 8 lb.  
 Weight of horn ..... 1/2 lb.  
 Weight total ..... 16 lb.



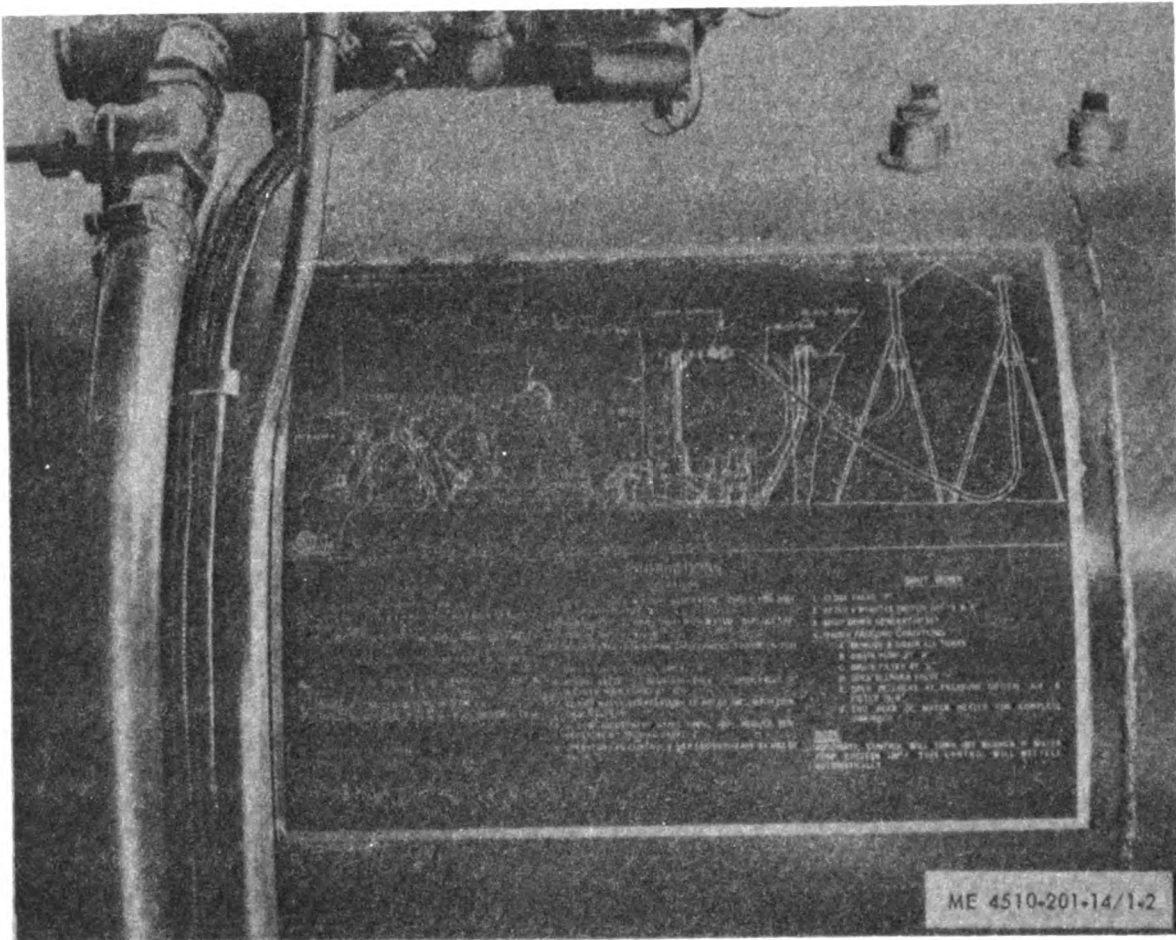


Figure 1-2. Bath unit instruction plate.

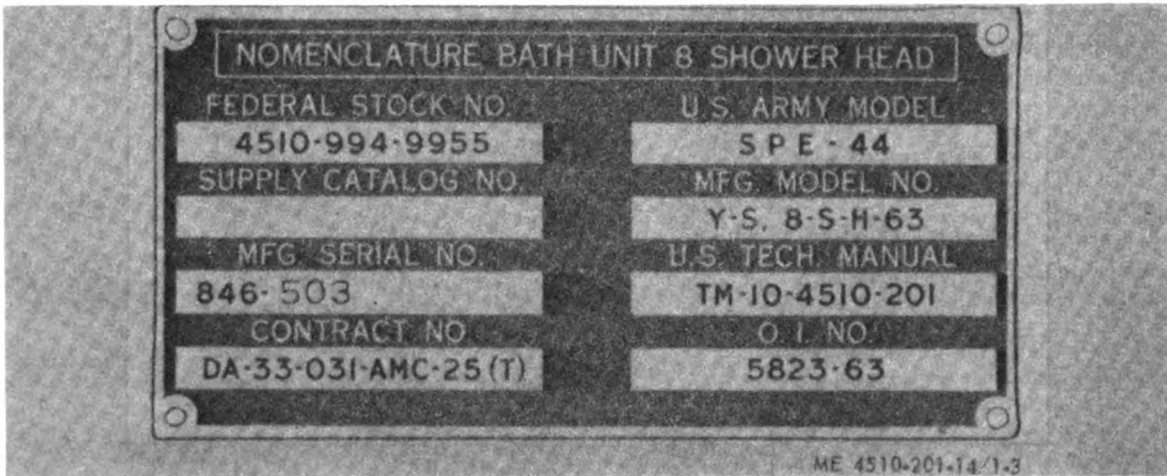


Figure 1-3. Bath unit data plate.

## CHAPTER 2

### OPERATING INSTRUCTIONS

#### Section I. SERVICE UPON RECEIPT OF MATERIAL

##### 2-1. Inspecting and Servicing

The services performed upon receipt of a new or a used bath unit are the responsibility of the using organization, and these services will be performed by organizational maintenance personnel. The operator can perform the operator preventive maintenance checks and services (para 3-1), and can assist in performing the lubrication instructions in section II, chapter 3.

##### 2-2. Installation

*a. Selecting a Site for Bath Unit.* Select a site for the bath unit beside a stream. Have the drainage from the shower area carried downstream or downhill from the suction hose strainer (10, fig. 1-

1) to prevent waste water from being drawn back into the water source. If this arrangement is not possible, dig a ditch or build a dike around the shower stands to allow waste water to drain away from the water source. If a pressurized water source is to be used, discharge the water into an open reservoir before it is drawn into the bath system to prevent straining the water pump unduly. Refer to figure 2-1 for operational layout for bath unit.

##### NOTE

Without a pasteurization kit, the water source must be approved by the unit surgeon. See safety precautions on inside cover page.

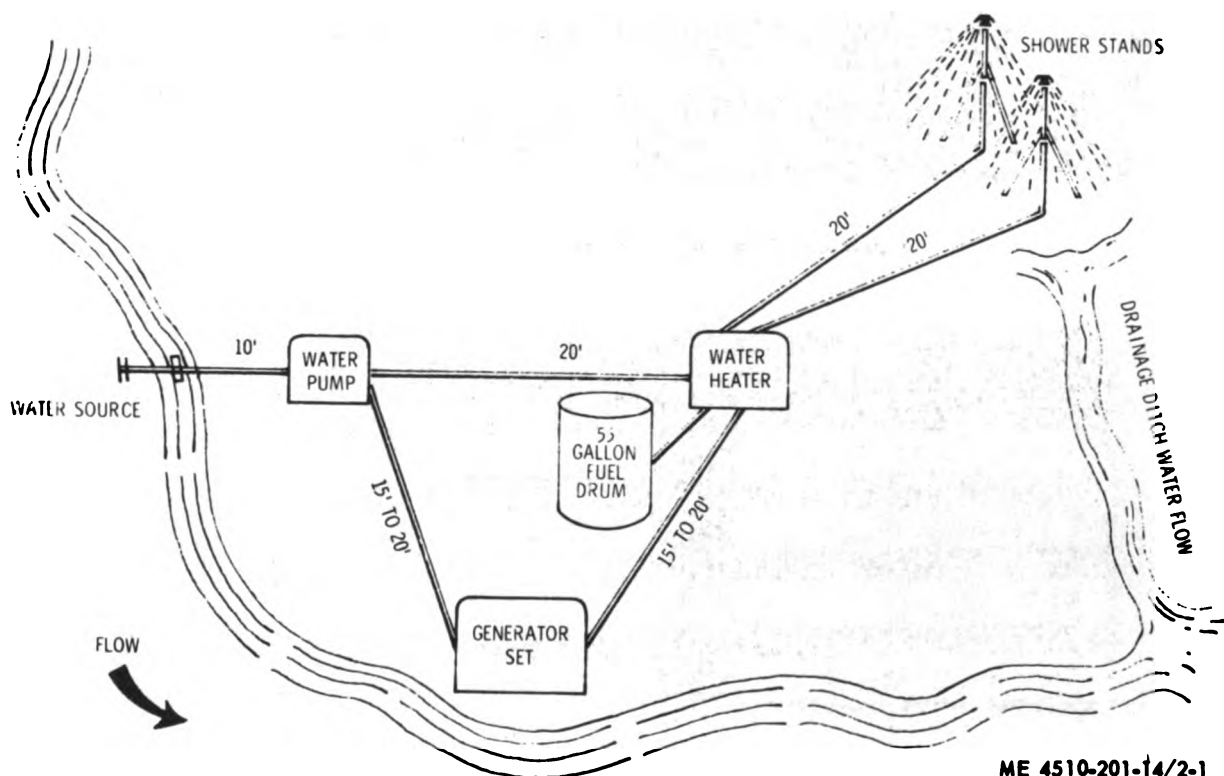


Figure 2-1. Operational layout for bath unit.

*b. Unloading Bath Unit.* The bath unit is designed to be carried on a baseboard in a 2½-ton, 6 x 6 truck. Locate the truck carrying the bath unit as closely as possible to the selected site, and unload the bath unit from the baseboard as follows:

(1) Remove the suction hose strainer (fig. 2-2) and the six shower stand legs (fig. 2-3) from the water heater burner exhaust duct.

(2) Remove the exhaust duct from the baseboard.

(3) Remove the suction hose assembly (1, fig. 2-4), the fuel hose assemblies, the barrel plug, the three water hose assemblies, and the two electric power cord cables from the baseboard.

(4) Unfasten the shower stand holddown webbing straps (3), holding the shower stand risers

to the baseboard, and remove the risers (2) from the baseboard.

(5) Remove the capscrews (1, fig. 2-5) that hold the water pump to the baseboard, and remove the water pump.

(6) Remove the four capscrews that hold the generator set to the baseboard, and remove the generator set.

(7) Lift the fire extinguisher (3) from the mounting bracket (4) on the baseboard.

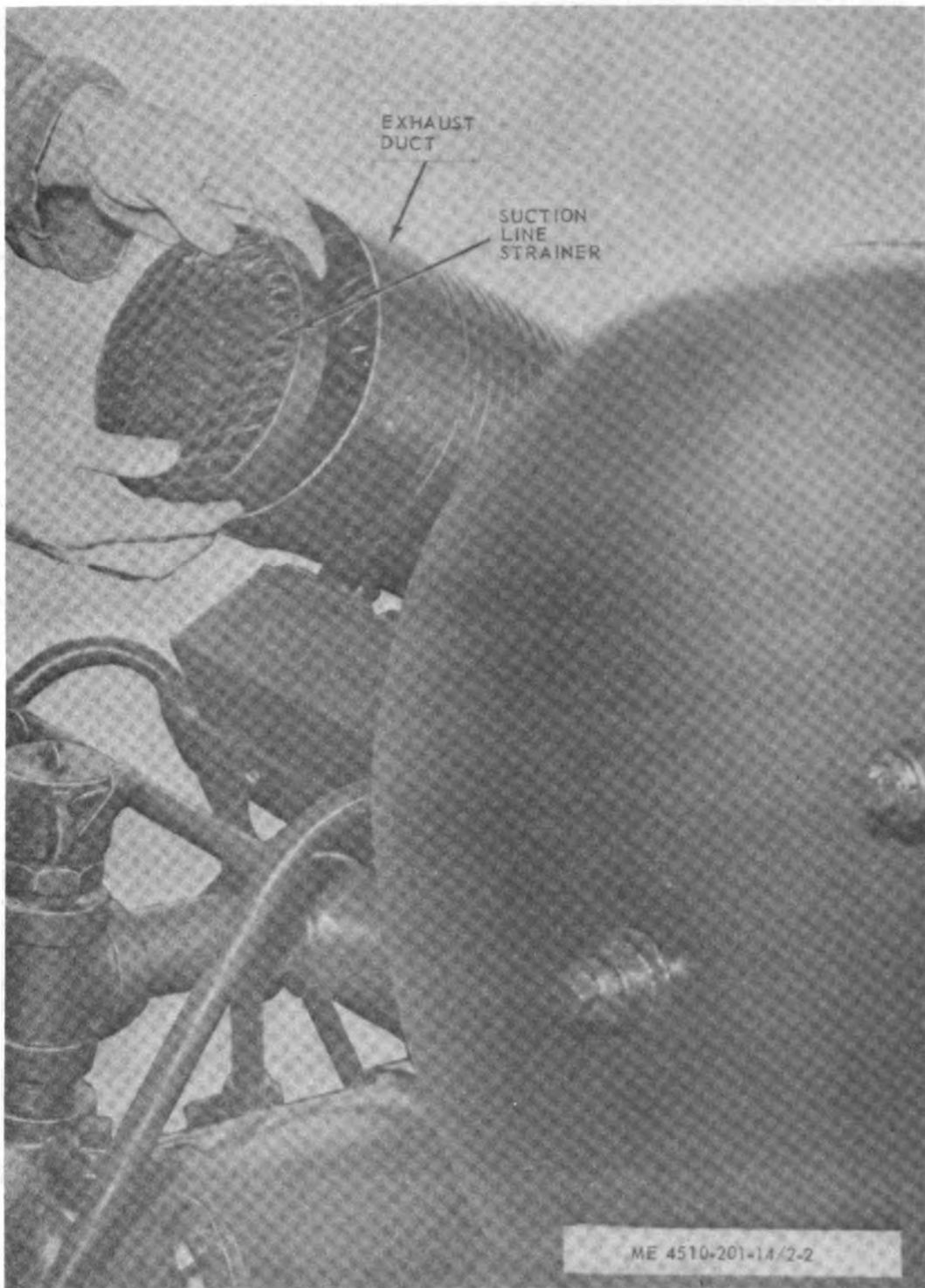
(8) Remove the four capscrews that hold the two water heater retaining brackets (2) located at the generator set end or the end opposite the fire

extinguisher of the water heater to the baseboard, and remove the two straps. Slide the water heater from under the other two retaining straps located at the fire extinguisher end of the water heater as it is mounted on the baseboard. Have four men, each grasping a handle on the water heater, lift the heater from the baseboard.

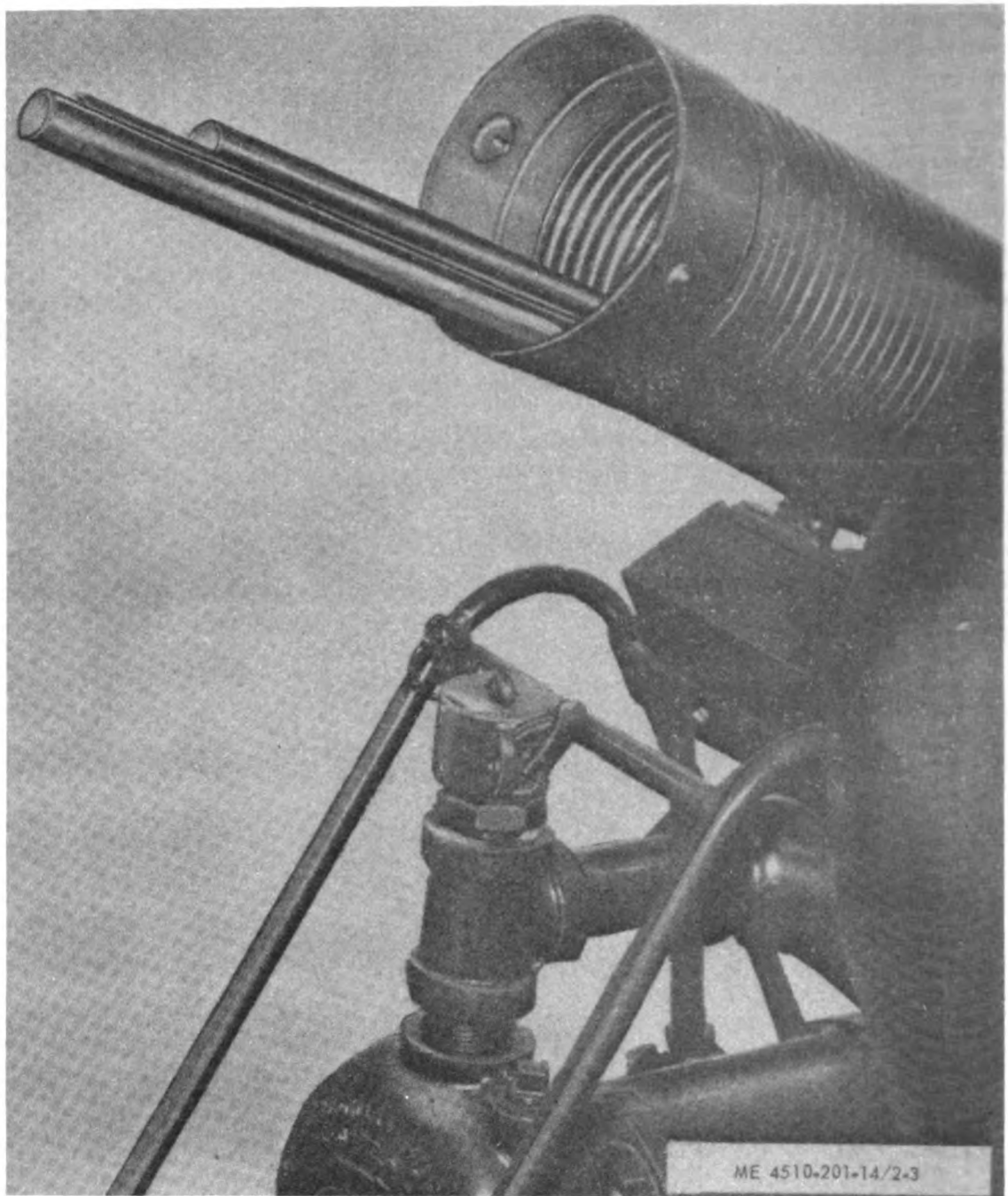
#### NOTE

After the bath unit has been removed from the baseboard, place all straps and capscrews in their proper location on the baseboard for temporary storage during the operation of the bath unit.

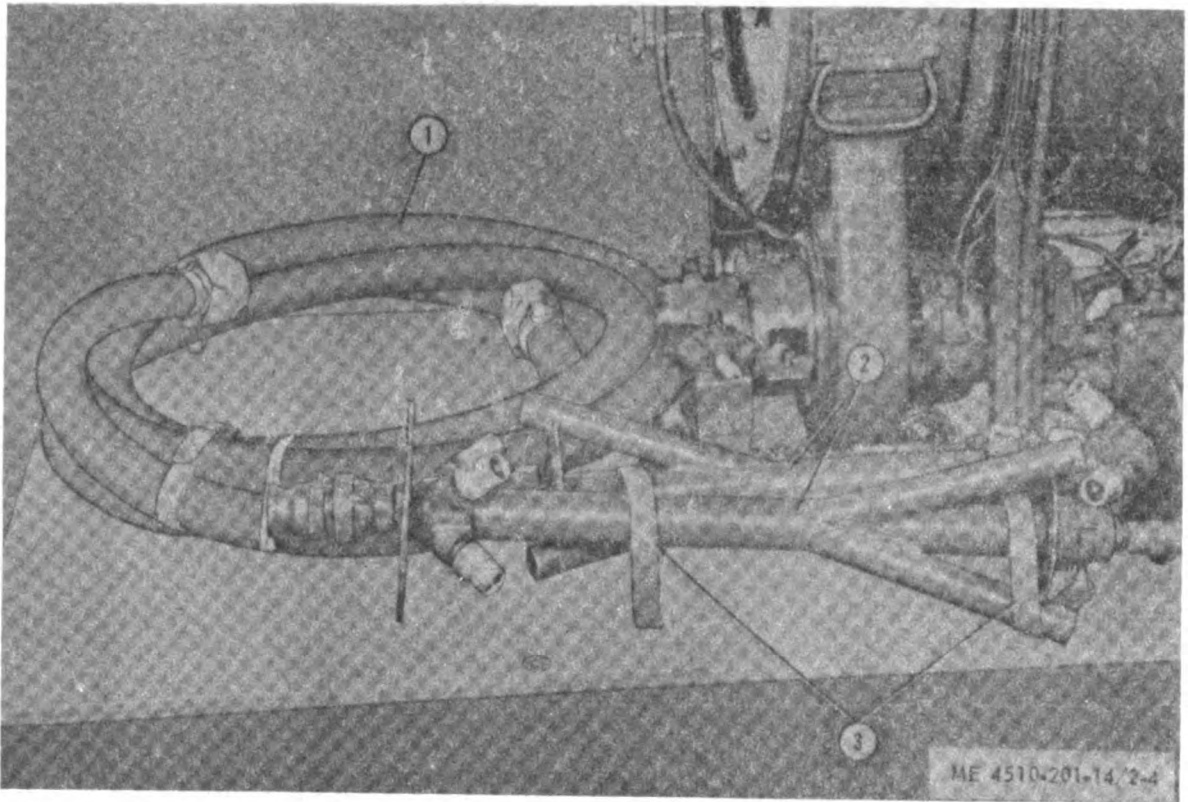
(9) Remove the baseboard from the truck.



**Figure 2-2. Removing suction hose strainer from exhaust duct.**

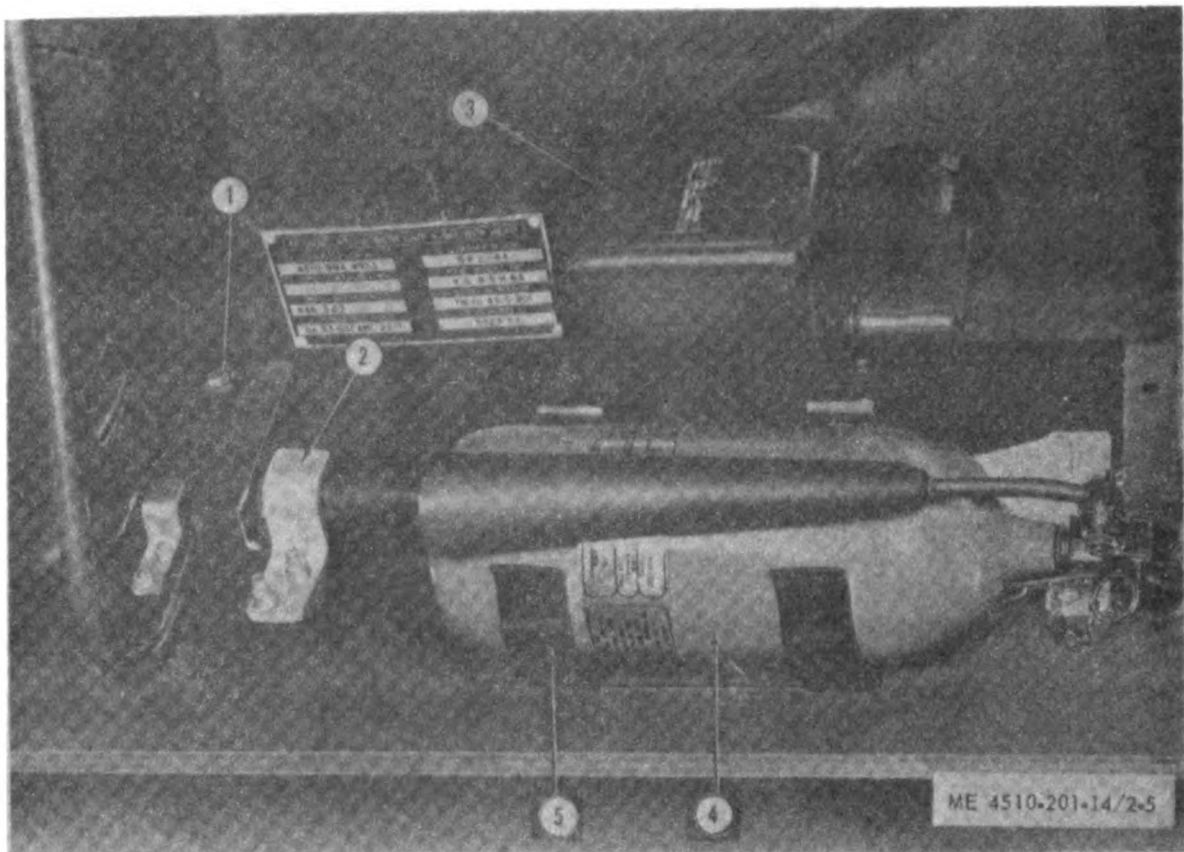


***Figure 2-3. Removing shower stand legs from exhaust duct.***



- 1 Hose assembly, suction
- 2 Risers, shower stand
- 3 Straps, webbing

*Figure 2-4. Suction hose assembly and shower stand risers on baseboard.*



- 1 Capscrew
- 2 Bracket water heater retaining
- 3 Ignition transformer
- 4 Extinguisher, fire
- 5 Bracket, fire extinguisher mounting

Figure 2-5. Baseboard retaining brackets.

c. **Setting Up Bath Unit.** After removing the bath unit from the baseboard, set it up at the selected site according to the layout in figure 2-1 as follows:

(1) Remove the straps from the hose assemblies, and place the straps on the baseboard.

**NOTE**

Before coupling the hose assemblies, be certain they are free of any foreign matter and that the coupling gaskets are present in each coupler.

(2) Couple the suction hose strainer (10, fig. 1-1) to one end of the suction hose (8), making certain the quick-disconnect coupler locking levers are secure.

(3) Place the suction hose assembly with the strainer into the water source, using one of the following methods:

(a) Center the strainer on a mound of stones or gravel as shown in A, figure 2-6. Pile large stones upstream, about 3 feet from the strainer, to divert any floating debris away from the strainer.

(b) Build a tripod from tree branches or saplings, and suspend the strainer from the top of

the tripod as shown in B, figure 2-6. Keep the leaves, weeds, and other debris from entering the strainer by building a barrier of twigs and small branches slightly upstream from the strainer.

(4) Place the water pump assembly on a level spot about 10 feet from the water source and connect the other end of the suction hose assembly (3, fig. 2-7) to the intake side of the water pump.

**NOTE**

Be sure the suction left does not exceed 15 feet.

(5) Place the water heater about 15 to 20 feet from the water pump and level the water heater by means of the level (fig. 2-11B), located on the skid below the blower housing. Whenever necessary and practical, arrange a suitable housing or windbreak for the heater to reduce the fuel consumption.

(6) Insert the adapter of one of the canvas hoses into the coupler (4, fig. 2-7), located on the discharge side of the water pump assembly. Take the other end of the hose, and attach it to the adapter (5, fig. 2-8), located on the lower manifold of the water heater.

(7) Place the fuel drum (3) approximately 5



feet away from the water heater. Install the barrel plug (2) into the large opening in the fuel drum. Connect one fuel hose assembly (1) to the fitting on the barrel plug marked SUPPLY, and connect the other end of the hose assembly to the fuel filter on the water heater. Connect the other fuel hose assembly (4) to the fitting on the barrel plug marked RETURN, and connect the other end to the fitting on the bottom of the fuel pump.

(8) Connect the exhaust duct (6) to the vent opening on the water heater. Turn the duct to the right to lock it in position.

**NOTE**

Do not allow the duct to come in contact with the hoses or any canvas shelter. Make certain the exhaust gases are expelled away from the shower area.

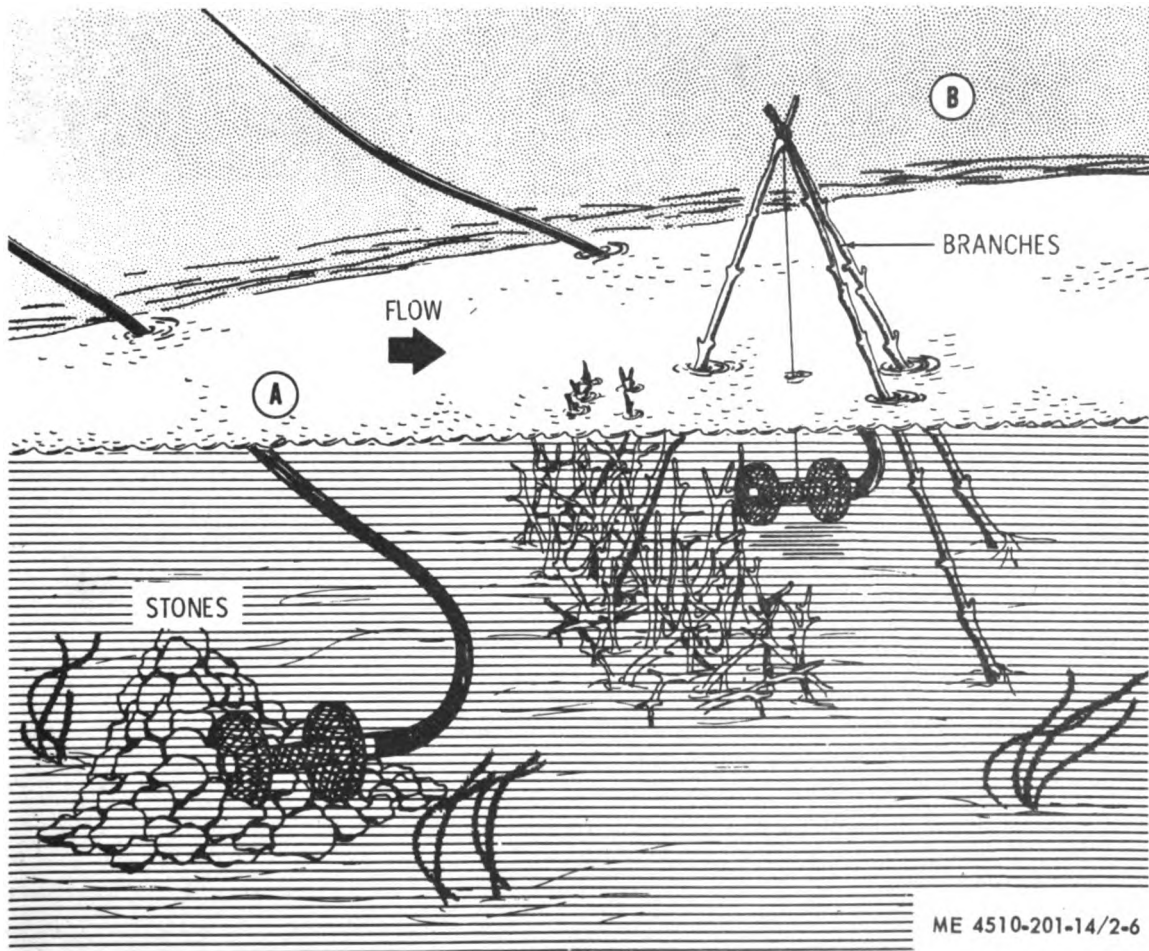
(9) Take the remaining two canvas water hose assemblies, and connect them to the couplers, located on the water heater upper manifold as shown in figure 2-9. Make sure the coupler gaskets are present and the coupler locking levers are

secure. Uncoil the hose assemblies their entire length (25 feet), and spread the coupler ends about 8 feet apart. Make certain the ends are located at the spot where the showers are to be taken and downstream from the water pump.

(10) Insert the three shower stand legs into the sleeves of each shower stand riser. Place the assembled shower stands beside each hose coupler. Make certain the coupler gaskets are present and then connect the hose assemblies to the shower stand adapters as shown in figure 2-10. Make certain the locking levers are secure.

(11) Place the generator set about 15 to 20 feet from the water pump and from the water heater (fig. 2-1).

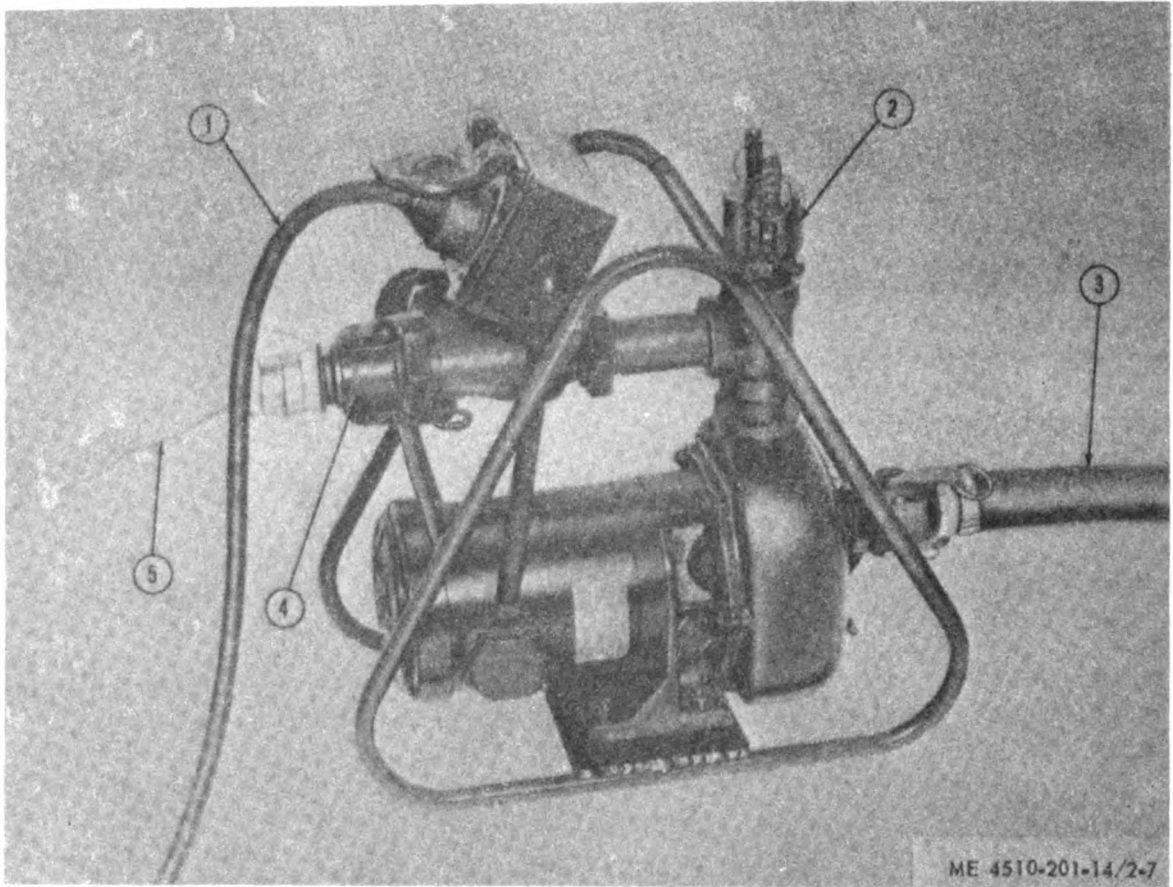
(12) Make certain the blower and fuel pump motor switch and the water pump motor switch are turned off before connecting the two power cord cables. Connect the two cables to the generator receptacle box connectors. Connect one cable (1, fig. 2-7) to the water pump receptacle connector and the other cable to the water heater receptacle connector.



A. Using stones or gravel  
B. Using tree branches and twigs

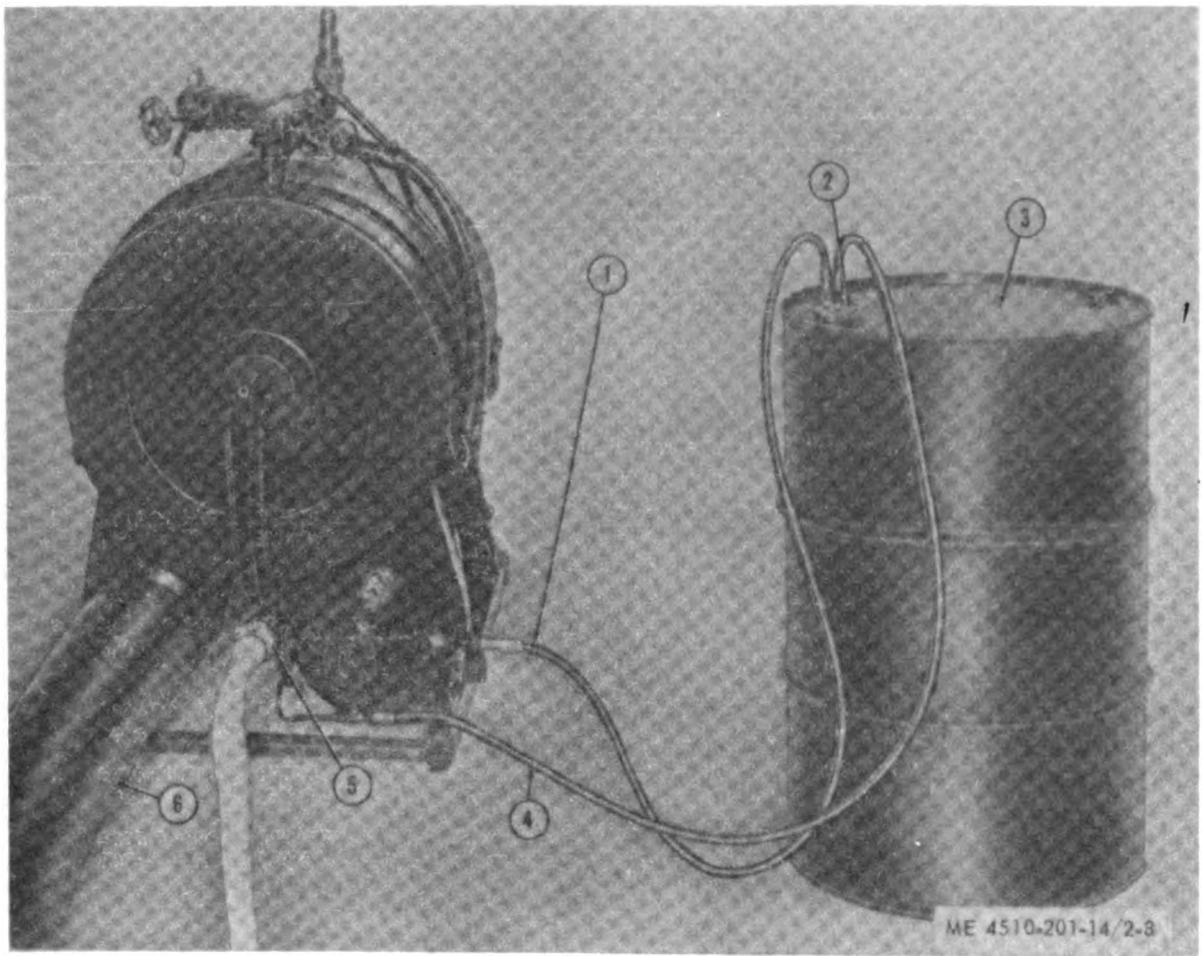
*Figure 2-6. Methods of positioning strainer in water source.*





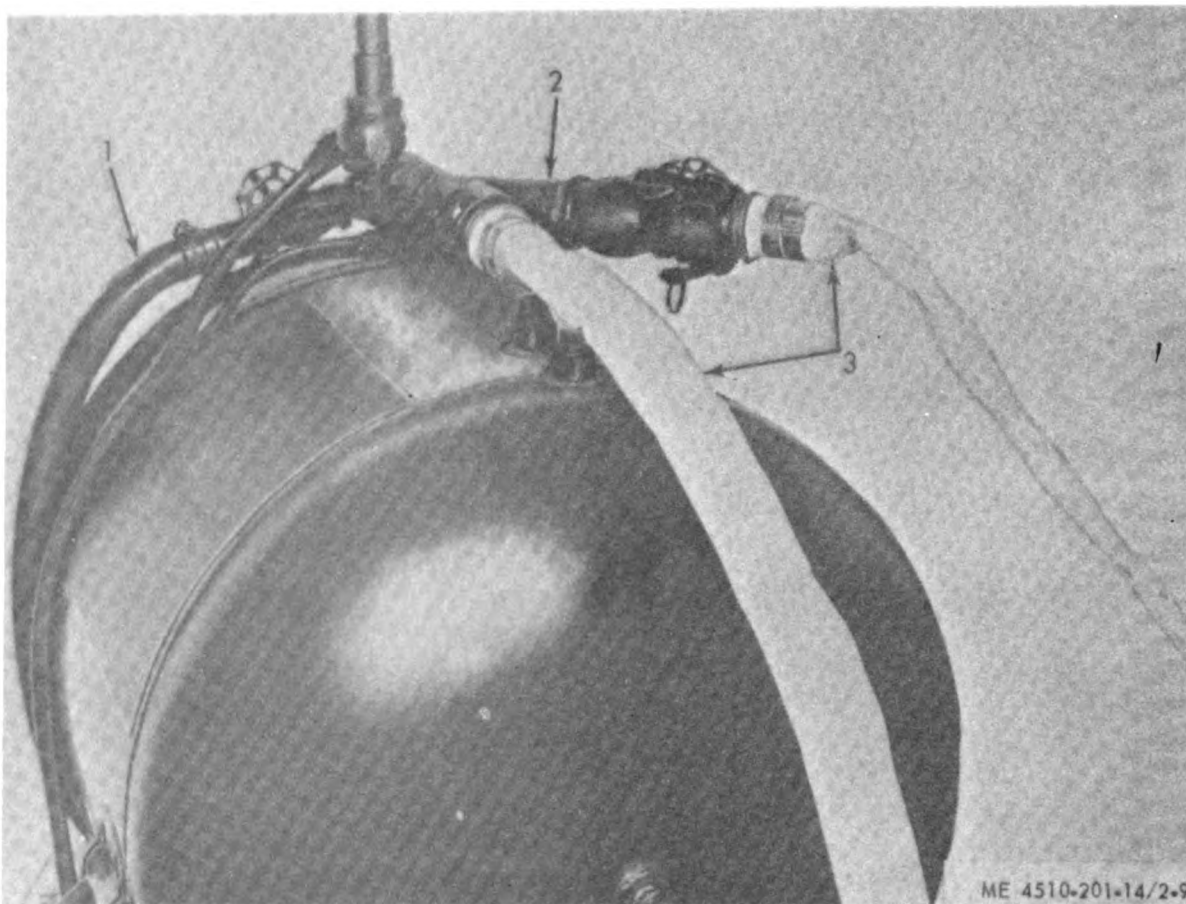
- 1 Cable, electric power cord
- 2 Cap, female dust
- 3 Hose assembly, suction
- 4 Coupler
- 5 Hose assembly, water

**Figure 2-7. Water pump and hose assemblies and cable connected.**



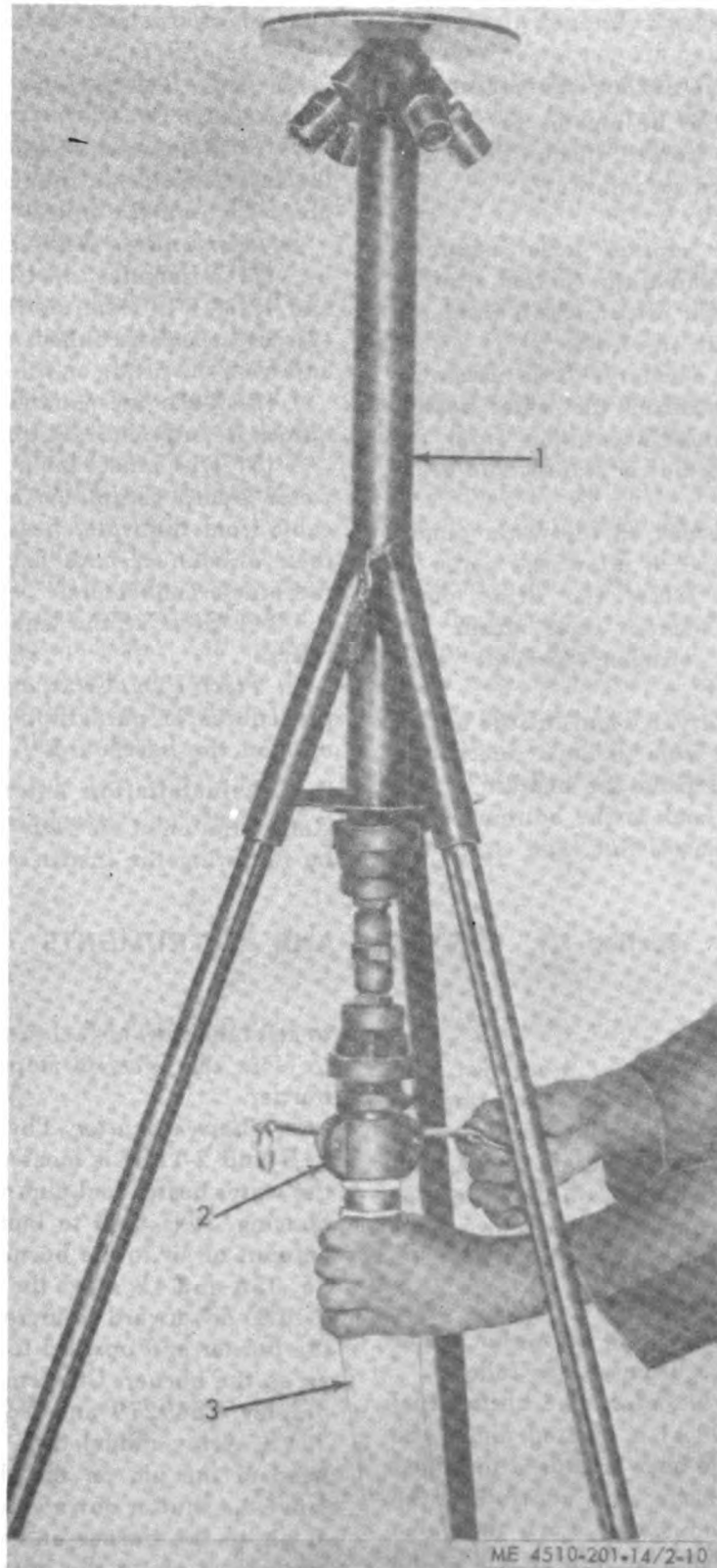
- 1 Hose assembly, fuel feed
- 2 Plug, barrel
- 3 Drum, fuel
- 4 Hose assembly, fuel return
- 5 Adapter
- 6 Duct, exhaust

*Figure 2-8. Hoses connected to water heater and fuel drum.*



1 Bypass hose  
2 Manifold  
3 Water hose (heater-to-shower stand)

*Figure 2-9. Hoses connected to heater manifold.*



- 1 Shower stand
- 2 Adapter
- 3 Water hose assembly

**Figure 2-10. Connecting water hose assembly to shower stand adapter.**

## Section II. MOVEMENT TO A NEW WORKSITE

### 2-3. Dismantling Bath Unit for Movement

Before the bath unit is to be moved to another worksite, drain all water from it, dismantle it, and place it on the baseboard as follows:

#### a. *Draining Bath Unit.*

(1) Disconnect the suction hose assembly from the water pump; remove the suction strainer from the water source, and disconnect it from the hose assembly; and drain the hose.

(2) Disconnect the discharge hose assembly from the water pump and from the water heater, disconnect the shower hose assemblies from the water heater and from the shower stands, and drain the hoses.

(3) Open the drain cock on the water pump, and tip the pump forward to allow the water to drain from the pump. Close the drain cock. Remove the strainer element and drain the chamber. Replace the strainer element after draining.

(4) Open the blender valve and lift the end of the heater (opposite end from exhaust duct), and allow the water to drain from the heater.

(5) Open the drain cock at the bottom of the water heater pressure control line, and drain the

water from the pressure control line. Close the drain cock.

(6) Remove the drain plug from the bottom of the fuel filter, drain the fuel filter, and replace the plug. Tighten the plug.

#### b. *Dismantling Bath Unit.*

(1) Disconnect the two fuel hose assemblies (1 and 4, fig. 2-8) from the fittings on the barrel plug (2), and then disconnect them from the fuel filter and from the fitting on the bottom of the fuel pump.

(2) Turn the exhaust duct (6) to the left to unlock it, and remove it from the water heater.

(3) Disconnect the power cord cable from the water pump receptacle connector and the other cable from the water heater receptacle connector; then disconnect both cables from the generator receptacle connectors.

(4) Remove the legs from the shower stand risers.

c. *Placing Bath Unit on Baseboard.* Reverse the procedures in paragraph 2-2 b to place the bath unit on the baseboard.

### 2-4. Reinstallation After Movement

Reinstallation of the bath unit can be accomplished by following the instructions in paragraph 2-2.

## Section III. CONTROLS AND INSTRUMENTS

### 2-5. General

This section illustrates, locates, describes, and furnishes the operator sufficient information pertaining to the use of the various controls and instruments provided for the operation of the bath unit. The controls and instruments on the generator sets are found in the appropriate technical manuals as listed in Appendix A or in paragraph 1-6 b.

### 2-6. Controls

The bath unit controls, located on the water heater and the water pump, are discussed as follows:

a. *Burner Fuel Control Valve.* The burner fuel control valve (4, fig. 2-11A) is located above the water heater control panel box. It is used to adjust the flow of fuel to the burner, thus controlling the temperature of the shower water. Turn the valve counterclockwise to decrease the flow of fuel to the burner and clockwise to increase the flow of fuel to the burner.

b. *Burner Fuel Shutoff Valve.* The burner fuel shutoff valve (1) is located behind the pressure and temperature control on the water heater. It is used to start and to stop the flow of oil to the burner. Turn the valve counterclockwise to open the valve

to start the flow of fuel to the burner and clockwise to close the valve to stop the flow of fuel to the burner.

c. *Blower Shutter.* The blower shutter (figs. 2-11B and 2-11C) is located and mounted between the water heater fuel pump bracket and the blower housing. It is used to increase or to decrease the amount of air to the burner. On Army model SPE 35, 35A and 41, move the lever on the shutter (fig. 2-11B) downward to increase the amount of air to the burner and upward to decrease the amount of air to the burner. On Army model SPE 44, York-Shipley YS49279 and York-Shipley model 8-SH-70YS, Army model SPE 45, press down on the head of the pin on the shutter (fig. 2-11C) and move the shutter downward to increase the amount of air to the burner and upward to decrease the amount of air to the burner.

d. *Shower Stand Control Valve.* The shower stand control valve (1, fig. 2-11D) is located on the upper manifold on top of the water heater. It is used to control the water flowing to the shower stands. Turn the valve clockwise to operate one shower stand and counterclockwise to operate both shower stands.

*e. Water Blender Valve.* The water blender valve (2) is located on top of the heater between the water bypass hose and the upper manifold. This valve allows cold water, coming directly from the water source, to enter the manifold and to mix with the heater water leaving the heater. Turn the valve counterclockwise to open the valve, allowing the cold water to mix with the heated water, and clockwise to close the valve, stopping the cold water from mixing with the heater water.

*f. Blower and Fuel Pump Motor Switch.* The blower and fuel pump motor switch is located under the switch cover (5, fig. 2-11A) on the water heater control panel box. It is used to start and to stop the motor. Lift up the switch cover and move the switch upward to the ON position to start the motor and downward to the OFF position to stop the motor.

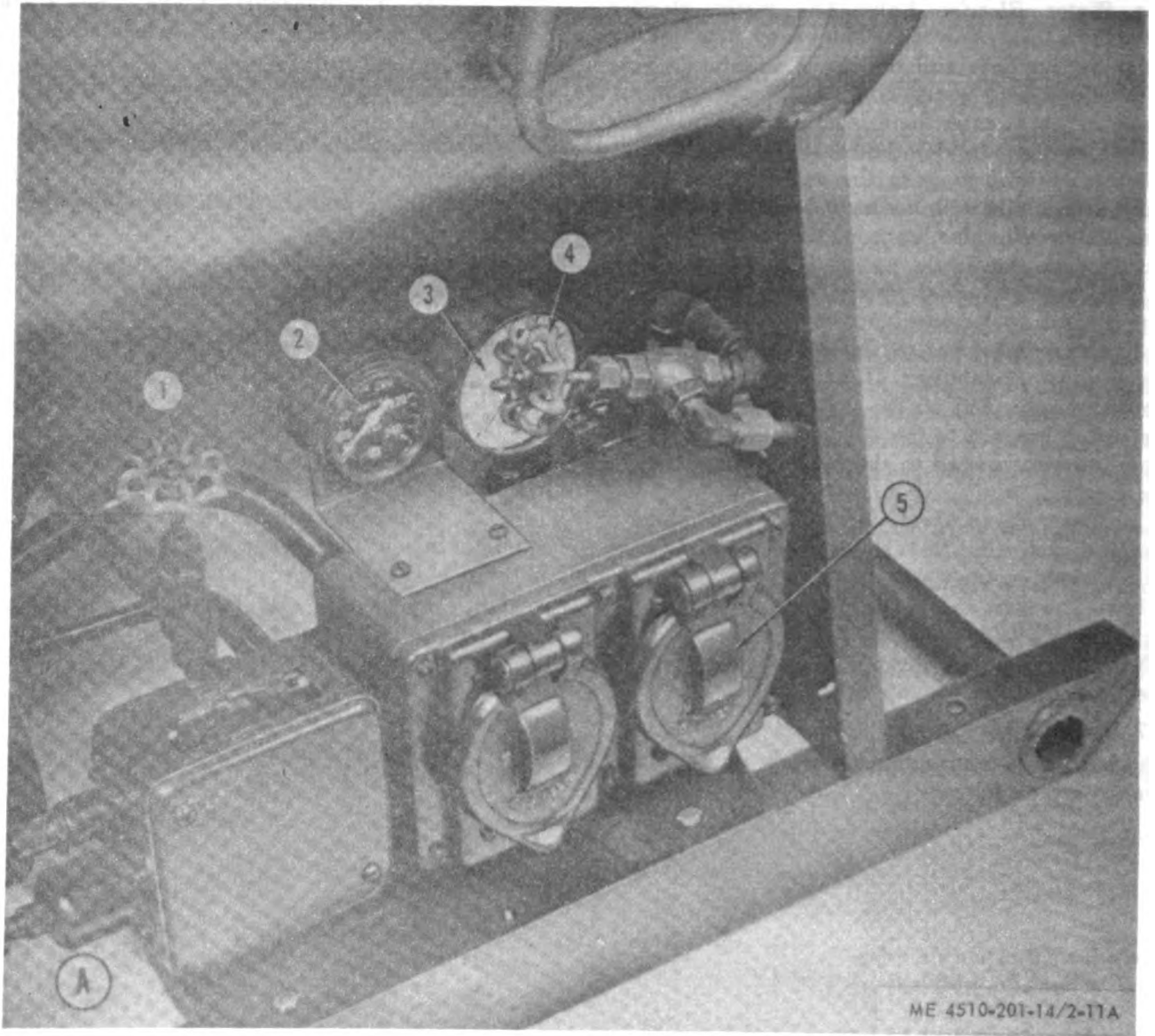
*g. Water Pump Motor Switch.* The water pump motor switch (fig. 2-11E) is located under the switch cover on the water pump control panel box. It is used to start and to stop the motor. Lift up the switch cover and move the switch upward to the ON position to start the motor and downward to the OFF position to stop the motor.

## 2-7. Instruments

The bath unit instruments, located on the water heater, are as follows:

*a. Water Temperature Gage.* The water temperature gage (2, fig. 2-11A) is located behind the water heater control panel box. It indicates the temperature of the water that is being supplied to the showers. On Army models SPE 35 and SPE 35A, the dial is graduated from 40° to 220° F. On Army models SPE 41, SPE 44, York-ShipleY model YS49279 and York-ShipleY model 8-SH-70YS, Army model SPE 45, the dial is graduated from 60° to 240° F. During operation of the bath unit, the normal temperature on the gage, for all models, should be between +95° and +105° F.

*b. Fuel Pressure Gage.* The fuel pressure gage (3, fig. 2-11A) is located on the water heater control panel box beside the water temperature gage (2). It registers the pressure in pounds per square inch of fuel being supplied to the burner. The dial is scaled from 0 to 160 pounds. The pressure will vary from 5 to 100 pounds per square inch according to the setting of the burner fuel control valve (para 2-5 a). With the burner fuel control valve set in the low-fire position, the gage should register 5 pounds per square inch; with it set in the medium-fire position, the gage should register 60 pounds per square inch; and with it set in the high-fire position, the gage should register 100 pounds per square inch.

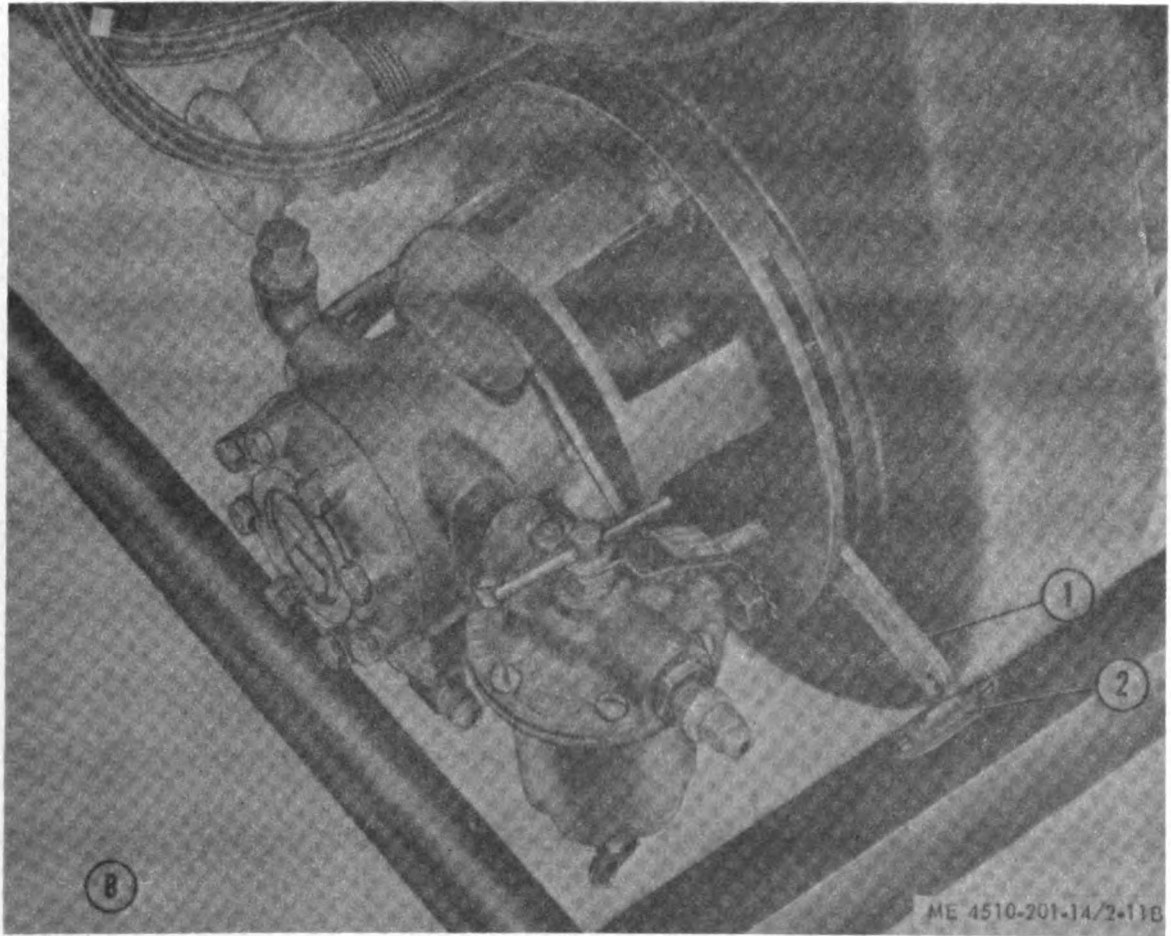


- |                              |   |
|------------------------------|---|
| 1 Valve, burner fuel shutoff | 4 Valve, burner fuel control                  |
| 2 Gage, water temperature    | 5 Cover, blower and fuel pump<br>motor switch |
| 3 Gage, fuel pressure        |   |

A. Water heater panel controls and instruments

**Figure 2-11. Bath unit controls and instruments  
(sheet 1 of 5).**



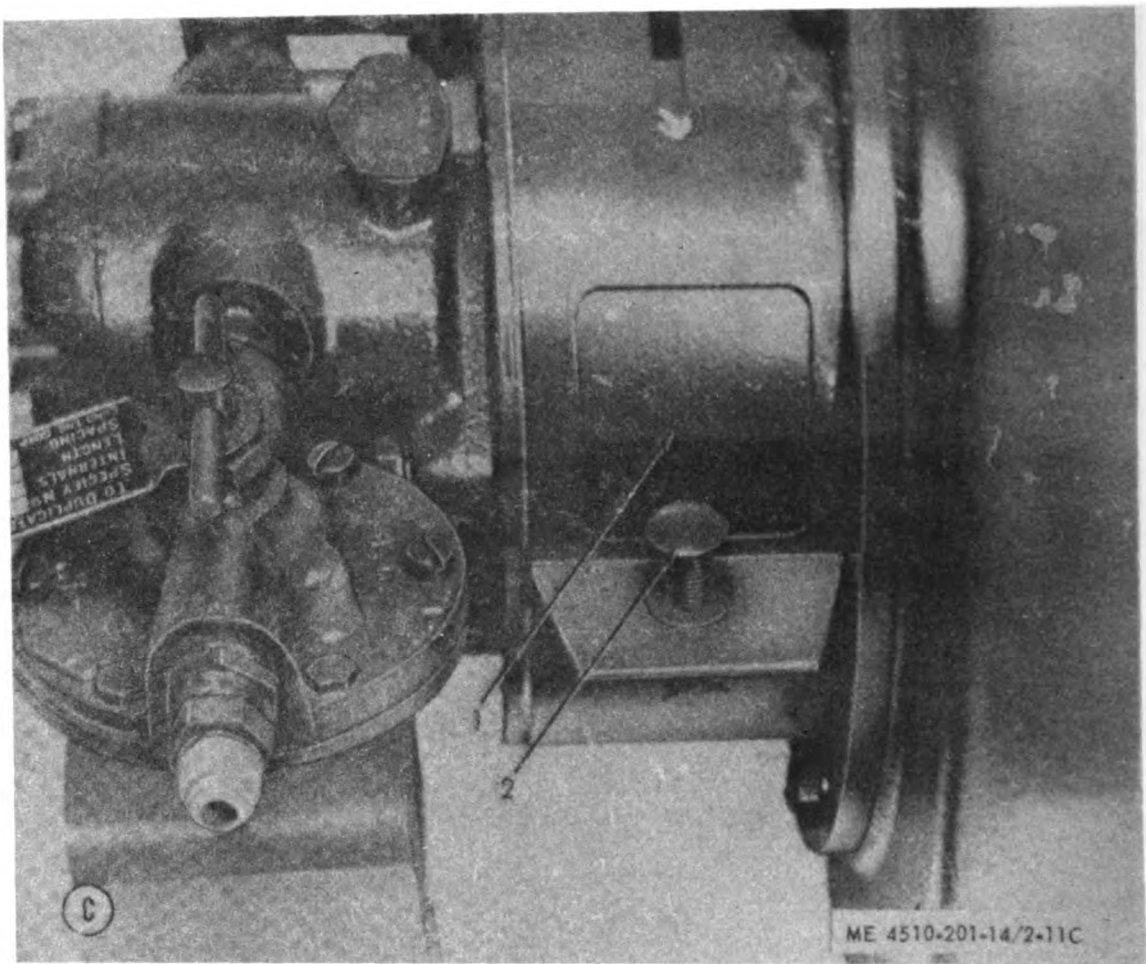


- 1 Shutter control lever
- 2 Level

B. Blower shutter (used on Army models SPE 35, SPE 35A and SPE 41)

*Figure 2-11. Bath unit controls and instruments  
(sheet 2 of 5).*

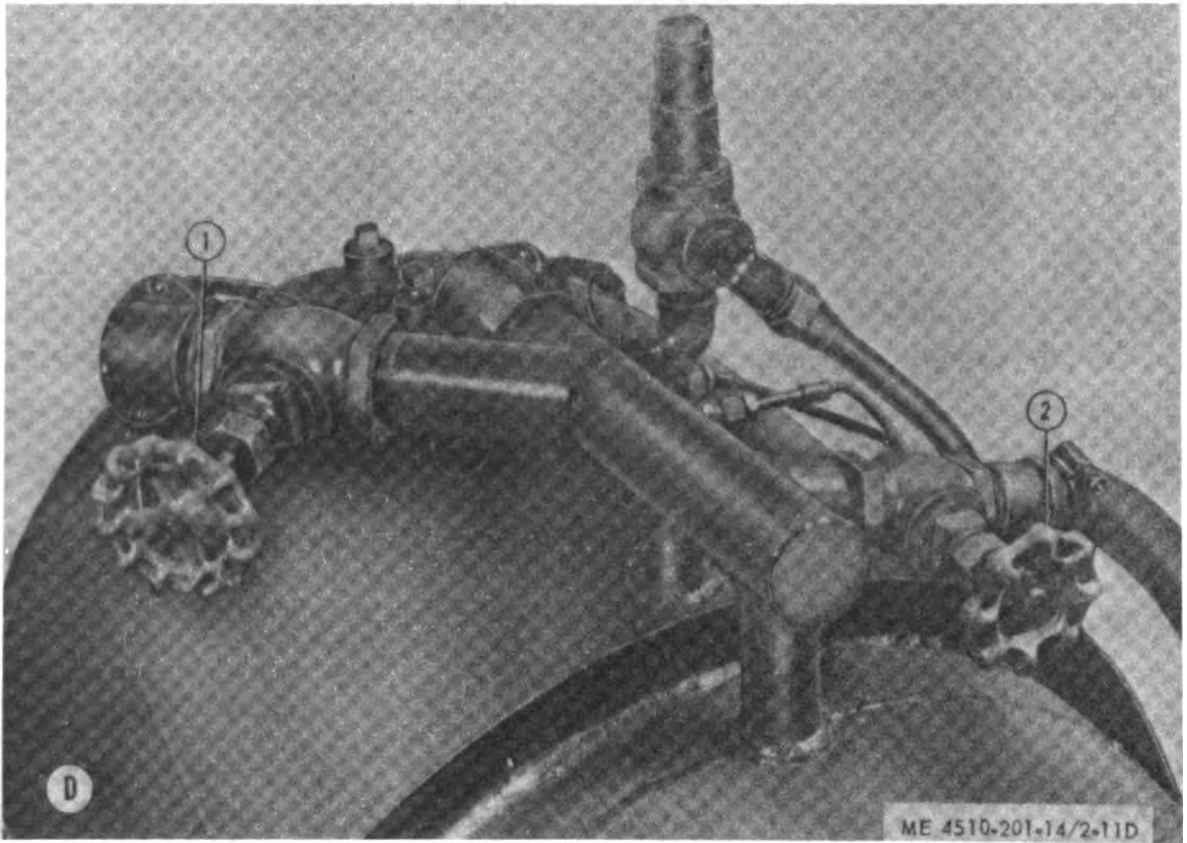




- 1 Fuel pump bracket
- 2 Shutter control knob

C. Blower shutter (used on Army models SPE 44, York-Shipley model YS40270 and Army model SPE 46)

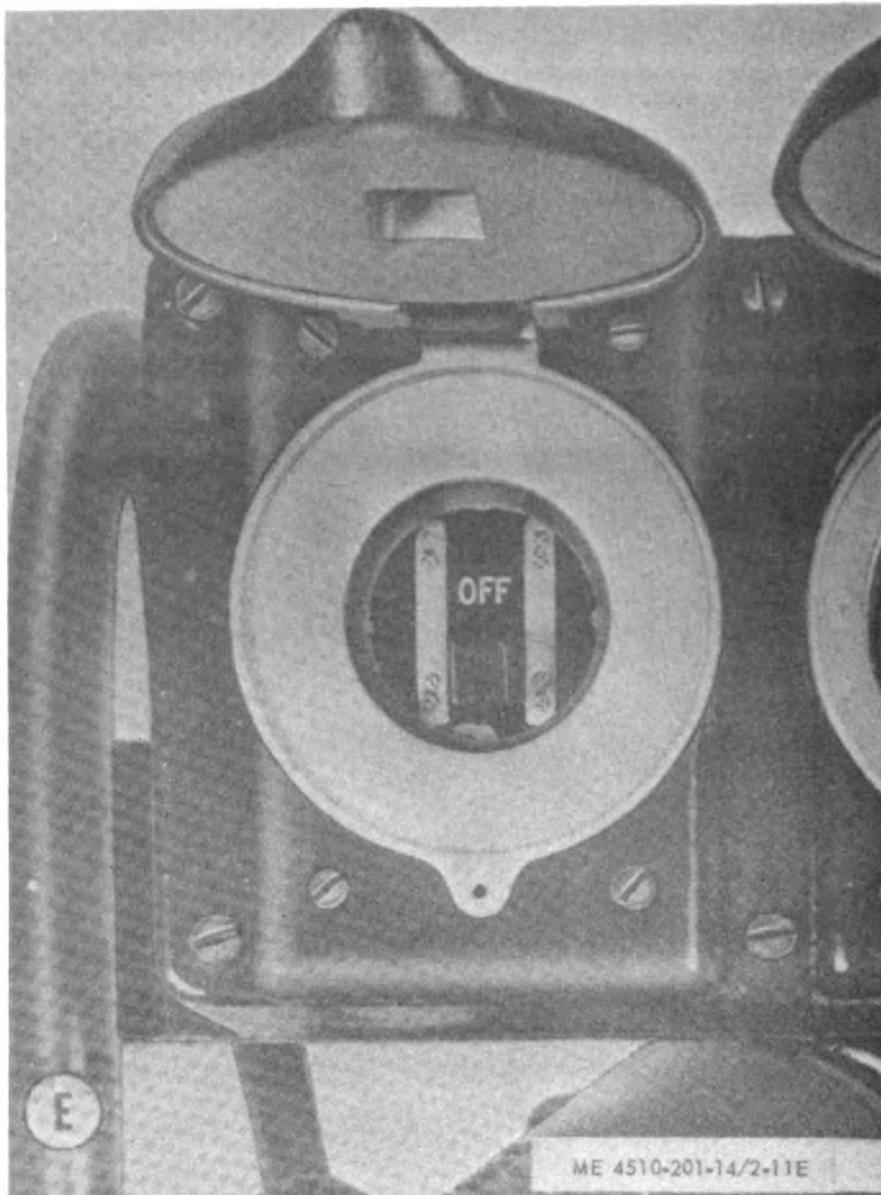
*Figure 2-11. Bath unit controls and instruments  
(sheet 3 of 5).*



- 1 Valve, shower stand control
- 2 Valve, water blender

D. Shower stand control and water blender valves

*Figure 2-11. Bath unit controls and instruments  
(sheet 4 of 5).*



E. Water pump motor switch

Figure 2-11. Bath unit, controls and instruments  
(sheet 5 of 5).

## Section IV. OPERATION UNDER USUAL CONDITIONS

### 2-8. General

a. The instructions in this section are for the information and guidance of personnel responsible for operation of the bath unit.

b. The operator must know how to perform every operation of which the bath unit is capable. This section contains instructions on starting and stopping the bath unit and on operation of the bath unit.

### 2-9. Preparation of Bath Unit for Operation

Before starting the bath unit, perform the preliminary inspections prescribed in the daily preventive maintenance services (para 3-2), and perform the following steps to prepare the bath unit for operation:

a. Check the generator fuel tank and the water heater fuel drum for adequate fuel.

b. Make certain the two power core cables, the

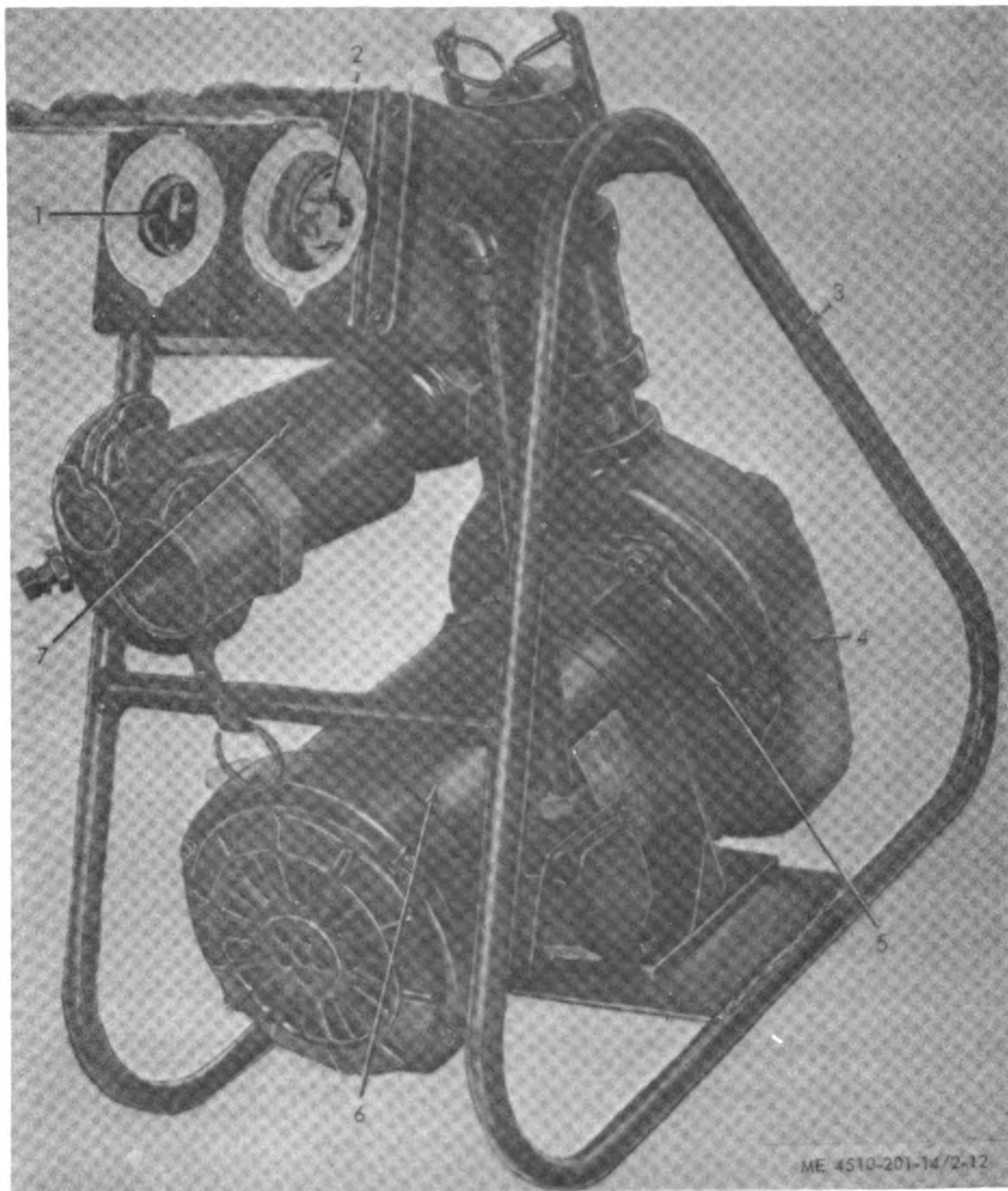
four water hose assemblies, and the two fuel line assemblies are properly connected.

c. Be sure the water pump motor switch (1, fig. 2-12) and the blower and fuel pump motor switch are in the OFF position.

d. Close the burner fuel shutoff valve (para 2-5 b) and the blower shutter (para 2-5 c).

e. Make certain the shower stand control valve (para 2-5 d) is open.

f. Be sure the water pump drain cock, the water heater drain cock, and the water pressure and temperature control drain cock are turned off.



- 1 Switch, motor
- 2 Connector, receptacle
- 3 Frame, tubular
- 4 Housing, pump

- 5 Pump, water
- 6 Motor, electric
- 7 Housing, strainer

Figure 2-12. Water pump assembly.

## 2-10. Starting Bath Unit

- a. Start the generator (para 2-16).
- b. Remove the dust cap (2, fig. 2-7), and fill the pump prime port with water. Replace the cap.

### **CAUTION**

Always operate the pump with water in the priming chamber to prevent the pump from overheating.

- c. Move the water pump motor switch (1, fig. 2-12) to the ON position.
- d. Observe the shower stands to be certain that water starts flowing from the nozzles; then move the blower and fuel pump motor switch to the ON position.
- e. Observe the fuel pressure gage (3, fig. 2-11A); it should register 100 pounds per square inch.

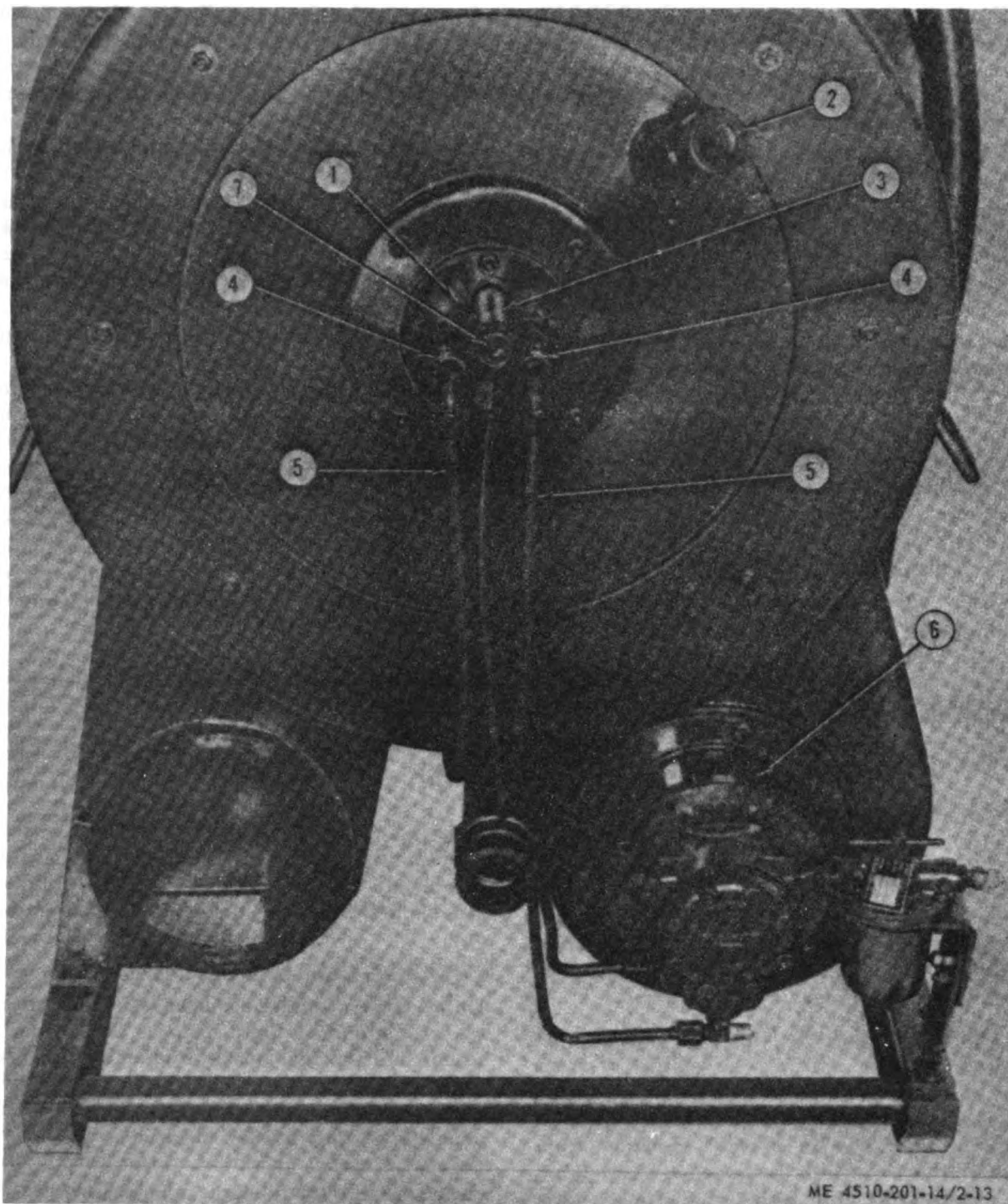
### **NOTE**

If the gage shows a pressure that is too low or too high, turn off the water heater blower and fuel pump motor switch, and refer to paragraphs 2-7b and table 3-2.

f. Look through the glass of the electrode sight tube bushing (3, fig. 2-3) to check the ignition spark on the tips of the electrodes. A continuous clear blue spark should be jumping the gap between the electrodes. If a purple spark is observed, electrode assembly is in need of adjustment.

g. Open the burner fuel control valve (4, fig. 2-11A) to starting position (60 psi), open the blower shutter (para 2-6c), and open the burner fuel shutoff valve (para 2-6b).

h. Look through the combustion chamber sight tube glass (2, fig. 2-13) to see if combustion flame is present.



- 1 Holder, nozzle and electrode
- 2 Glass, combustion chamber sight tube
- 3 Nipple, electrode sight tube pipe
- 4 Electrodes, ignition

- 5 Cable assemblies, ignition
- 6 Shutter, blower
- 7 Bushing, electrode sight tube

*Figure 2-13. Water heater, left end view.*

### 2-11. Operating Bath Unit

After starting the bath unit, operate it as follows:

- a. Adjust the blower shutter (para 2-6 c) so that the exhaust from the water heater is transparent and smokeless.

#### NOTE

During operation, the shutter may change its position because of vibration. Check the shutter constantly, and adjust it as necessary.

b. Check the water temperature gage (2, fig. 2-11A) to see that the temperature registers between 95° and 105° F. after a few minutes of operation. If the incoming water supply is extremely cold or warm, change operating conditions of the heater as follows:

(1) *Cold incoming water.* If the temperature on the gage does not move after a few minutes of operation, close the burner fuel control valve (4) very slowly until the gage registers a temperature between 95° and 105° F.

#### NOTE

The burner will automatically shut off if the water temperature exceeds 120° F., and it will start again when the water temperature drops to the control setting.

c. Open or close the shower stand control valve (para 2-6 a) to operate either one or both shower stands. Since the number of shower nozzles being operated will vary the flow of water to be heated and the temperature of the water, check the temperature gage every few minutes.

### 2-12. Stopping Bath Unit Operation

a. Close the burner fuel shutoff valve (4, fig. 2-11A).

b. Allow the bath unit to operate a few minutes

after the burner fuel shutoff valve (1, fig. 2-11A) is closed, in order for the blower to purge any vaporized fuel from the burner.

c. Turn off the blower and fuel pump motor switch located under the switch cover (5).

d. Turn off the water pump motor switch (1, fig. 2-12).

e. Stop the generator (para 2-16).

f. Open the drain cock on the bottom of the water heater, and drain the condensation from the combustion chamber. Do not drain water from the bath unit if it is to be shut down for only a short period such as overnight, unless there is danger of freezing.

g. Perform the following procedure for putting oil in the pump when the bath unit is to remain idle for 5 days or more:

(1) Remove the end of the water heater fuel feed hose assembly from the 55-gallon fuel drum.

(2) Place the end of the hose assembly into a quart container filled with OE-30 for temperatures of or above 32° F., OE-10 for temperatures of +40° to -10° F., or OES for temperatures of 0° to -65° F.

(3) Operate the fuel pump until the quart container is empty, and then stop the pump.

## Section V. OPERATION UNDER UNUSUAL CONDITIONS

### 2-13. General

This section contains the necessary operating instructions, in addition to those previously covered, which are necessary for the bath unit to function properly under unusual conditions, such as in cold weather and dusty areas.

### 2-14. Operation in Cold Weather

To operate the bath unit in cold weather or areas subject to freezing, be sure to fill the generator engine fuel tank and the water heater fuel drum at the end of operation to prevent moisture from collecting. Check carefully for frozen or burst pipes, joints, connections, and hoses immediately after starting operation. Make provisions to prevent the water hose assemblies, the water pump, and the water heater from freezing. Whenever the bath unit

is shutdown during freezing weather, it must be completely drained (para 2-3 a), the drain cocks must be left open, and the drain plugs must be left out.

### 2-15. Operation in Dusty Areas

Under dusty conditions, keep all fuel containers covered and dust tight. Inspect the burner electrodes and the fuel nozzle frequently because the accumulation of dust and dirt in the burner, by way of the blower, may increase the collection of carbon deposits on the burner electrodes and the fuel nozzle. During operation, inspect the burner electrodes through the sight tube glass. If the spark, instead of firing at the electrode gap, is moving up and down on the electrodes, it is an indication that the electrodes are coated with carbon deposits and must be cleaned.

## Section VI. OPERATION OF MATERIAL USED IN CONJUNCTION WITH THE BATH UNIT

### 2-16. General

This section contains the necessary instructions, illustrations, descriptions, and references for

operating the auxiliary materiel used in conjunction with the operation of the bath unit. The auxiliary materiel includes a fire extinguisher, a generator

set, and a 55-gallon fuel drum. The fuel drum is used to furnish fuel to the water heater. The generator set is used to furnish power to operate the bath unit, and a description of and the operation and maintenance procedures for the generator sets are given in the appropriate technical manuals listed in paragraph 1-6 *b*. The necessary instructions for the operation and maintenance of the fire extinguisher are found in paragraph 2-17 below.

#### **2-17. Fire Extinguisher**

A 5-pound carbon dioxide (CO<sub>2</sub>) fire extinguisher (4, fig. 2-5), furnished with the bath unit, is generally suitable for all types of fires which ordinarily may occur in connection with the bath unit. The operation and maintenance instructions are found by referring to TB 5-4200-200-10.





## CHAPTER 3

# OPERATOR'S MAINTENANCE INSTRUCTIONS

---

### Section I. BASIC ISSUE ITEMS

Equipment and technical manuals issued with or authorized for the bath unit are listed in the Basic

Issue Items List, appendix C.

### Section II. LUBRICATION INSTRUCTIONS

The bath unit requires no lubrication except for the auxiliary equipment—the generator set. The lubrication instructions for the generator sets are found in TM 5-6115-271-14 as listed in appendix A. The electric motors on the water heater and on the water pump are factory-sealed and require no lubrication.

#### **CAUTION**

When firing fuel burner with gasoline, mix one quart OE-30 oil with each five gallons of gasoline. This mixture will provide internal lubrication for the fuel pump. To assure proper mixture ratio, pour gasoline into the oil.

### Section III. PREVENTIVE MAINTENANCE CHECKS AND SERVICES

#### 3-1. General

To insure that the bath unit is ready for operation at all times, it must be inspected systematically so that defects may be discovered and corrected before they result in serious damage or failure. The necessary preventive maintenance services to be performed on the bath unit are listed and described in paragraph 3-2. The item numbers indicate the sequence of minimum inspection requirements.

Defects discovered during operation of the bath unit shall be noted for future correction, to be made as soon as operation has ceased. Stop operation immediately if a deficiency is noticed which would damage the equipment if operation were continued. All deficiencies and shortcomings, together with the corrective action taken, will be recorded on DA Form 2404 (Equipment Inspection and Maintenance Worksheet) at the earliest possible opportunity.

Table 3-1. Preventive Maintenance Checks and Services.

Item number	Interval						Item to be Inspected	Procedure	Reference			
	Operator			Org.						B — Before Operation	A — After Operation	M — Monthly
	B	D	A	W	M	Q				D — During Operation	W — Weekly	Q — Quarterly
1	X		X				Water line strainer	Inspect for dirty, broken and leaking strainer.	Paragraph 3-11			
2	X	X	X			Sight tube glass	Inspect for dirty and broken glass.					
3	X	X	X			Burner nozzle and electrode holder	Inspect nozzle and electrode holder for loose mounting. Inspect lead assemblies for loose connections. Check firebox for improper combustion, and electrode for improper spark (during operation).					
4	X	X	X			Fuel line and hose assemblies	Check for loose connections and for broken, bent, and leaking line and hose assemblies.	Paragraph 3-7				
5	X		X			Fuel drum	Check level of fuel supply and check for leaks in drum.					
6	X	X	X			Water hose assemblies	Check for cracked, collapsed, and leaking hoses, and for loose connections.					
7	X		X			Shower head nozzles	Inspect for dirty and clogged nozzles.	Paragraph 3-10				
8	X	X				Instruments	Check for broken lenses, illegible markings, and loose connections. Check for incorrect temperature and for pressure that is too high or too low (during operation).	Paragraph 2-11				
9	X		X			Drain plugs and drain cocks	Check for improper installation of drain plugs and drain cocks.	Paragraph 3-6				
10	X	X				Fuel filter	Check for leaking and dirty filter. Hand lever must be turned one complete turn daily.					
11	X		X			Exhaust duct	Inspect for broken, dirty, and leaking duct and for loose connections. Be sure the duct is not clogged or does not contain any flammable litter.					
12	X					Power cord cables	Check for loose or broken connections and for cracked and deteriorated insulation.	Paragraph 2-17.				
13	X	X	X			Suction strainer	Inspect for dirty and clogged strainer. Check for improper positioning of strainer (during operation).					
14	X					Fire extinguisher	Inspect for broken seal.					
15	X	X	X			Water heater	Check for water leaks.					
						Note 1. Ground terminal	Before operation, make sure generator set is properly grounded.					
						Note 2. Operational test	During operation, observe for excessive vibration and noisy motors.					

**3-2. Operator Preventive Maintenance**  
 The operator's periodic preventive maintenance

checks and services are listed in table 3-1.

## Section IV. TROUBLESHOOTING

### 3-3. General

a. This section contains troubleshooting information for locating and correcting most of the operating troubles which may develop in the bath unit. Each malfunction for an individual component, unit, or system is followed by a list of tests or inspections which will help you to determine probable causes and corrective actions to take. You

should perform the tests/inspections and corrective actions in the order listed.

b. This manual cannot list all malfunctions that may occur, nor all tests or corrections and corrective actions. If a malfunction is not listed or is not corrected by listed corrective actions, notify your supervisor.

### 3-4. Operator's Troubleshooting

The troubleshooting table (table 3-2) is as follows:

*Table 3-2. Troubleshooting*

MALFUNCTION	TEST OR INSPECTION	CORRECTIVE ACTION
<b>MISCELLANEOUS</b>		
<b>1. BLACK SMOKE COMES OUT OF BURNER EXHAUST DUCT.</b>		
	Step 1. Check to see if fuel-to-air ratio adjustment is improper.	Adjust shutter for proper volume of air intake (para 2-11a).
<b>SHOWER STAND AND WATER PUMP ASSEMBLY</b>		
<b>1. SHOWER STAND NOZZLES NOT DISCHARGING ENOUGH WATER</b>		
	Step 1. Check to see if shower nozzles are clogged.	Clean shower nozzles (para 3-10).
	Step 2. Check to see if shower hose has collapsed.	Straighten hose.
	Step 3. Check to see if shower stand control valve is closed.	Open valve fully (1, fig. 2-11D).
<b>2. WATER PUMP FAILS TO DELIVER WATER</b>		
	Step 1. Check to see that suction lift does not exceed 15 feet.	Move pump closer (15-foot lift or less) to water level.
	Step 2. Make sure that pump is primed sufficiently.	Prime water pump by filling pump body with water.
	Step 3. Make sure water source is not too shallow.	Position suction strainer in deeper water.
	Step 4. Check for air leaks in hose assemblies.	Check and tighten all hose connections. Install new gaskets if necessary (para 2-7).
	Step 5. Check to see if suction hose is clogged.	Remove suction strainer and suction hose from water, and clean trash and other obstruction from the hose by flushing the hose.
	Step 6. Check for clogged water line strainer.	Clean water line strainer element (para 3-11b).
<b>WATER HEATER ASSEMBLY</b>		
<b>1. FLAME FAILS IN BURNER</b>		
	Step 1. Check to see if fuel supply is adequate.	Fill fuel drum.
	Step 2. Check to see if ignition cable assemblies are loose.	Tighten connections.
<b>2. BURNER FUEL PUMP FAILS TO DELIVER FUEL</b>		
	Step 1. Check to see if fuel supply is adequate.	Fill fuel drum.

Table 3-2. Troubleshooting (Cont'd).

MALFUNCTION	TEST OR INSPECTION	CORRECTIVE ACTION
<b>WATER HEATER ASSEMBLY—Continued</b>		
	Step 2. Check for air leaks in fuel hose.	Tighten fuel hose connections.
	Step 3. Check to see if feed and return fuel hose assemblies are reversed.	Connect hose assemblies and barrel plug properly.
	Step 4. Make sure fuel pump has been primed.	Turn off blower and fuel pump motor. Prime fuel pump by removing prime plug and pouring fuel into prime port. Replace and tighten plug.
<b>3. LOW OR HIGH FUEL PRESSURE INDICATED ON GAGE</b>	Step 1. Check burner fuel control valve.	To increase the fuel pressure, turn the valve clockwise; to decrease the fuel pressure, turn the valve counterclockwise (para 2-6a).
<b>4. PULSATING PRESSURE INDICATED ON PRESSURE GAGE</b>	Step 1. Check for leaking fuel feed hose assembly.	Tighten fuel hose assemblies.
	Step 2. Inspect for loose strainer cover.	Tighten all cover screws.

## Section V. MAINTENANCE OF MISCELLANEOUS ITEMS

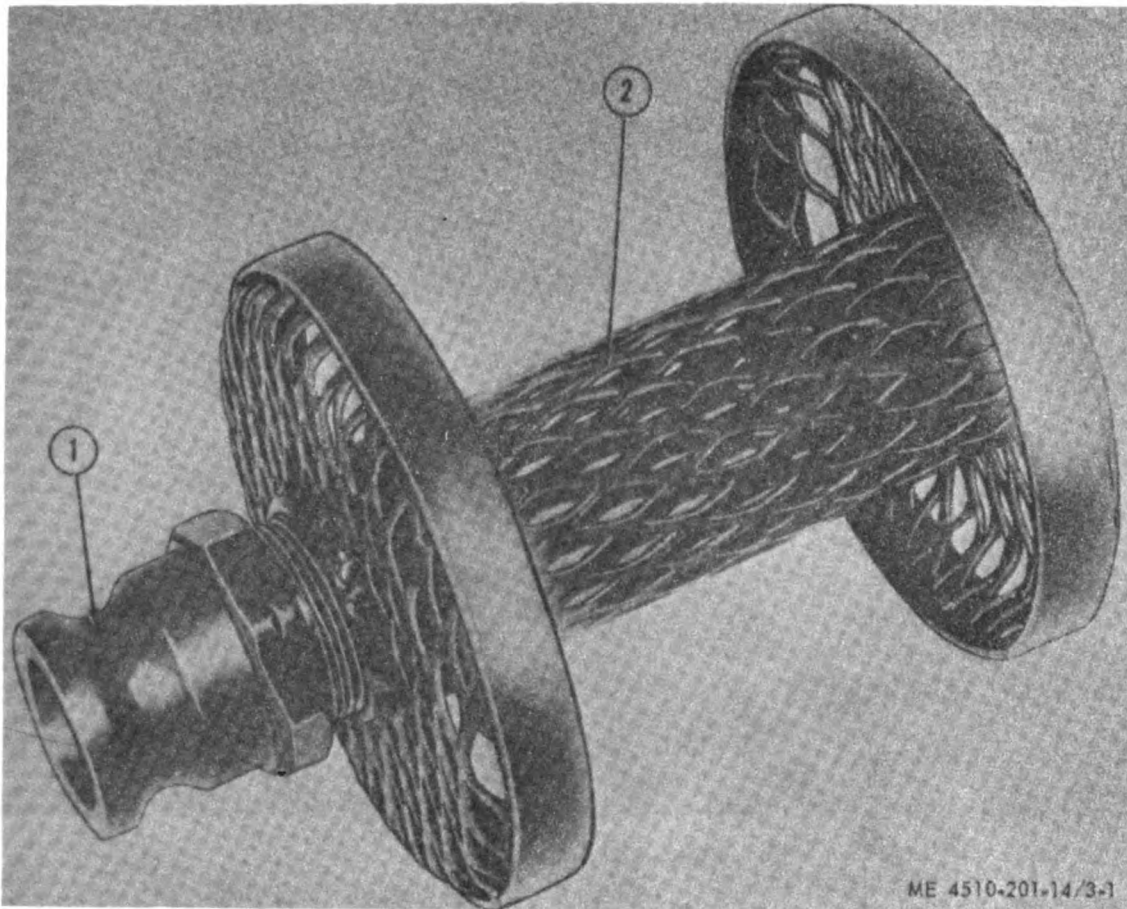
### 3-5. General

This section describes maintenance functions of items which are listed in Group No. 01 of the MAC and which the operator must perform. Any deficiency which the operator is not authorized to correct must be reported as stipulated by TM 38-750.

### 3-6. Suction Strainer

*a. Description.* The suction hose strainer (2, fig. 3-1) is connected to the suction hose assembly, and it is used to prevent leaves and debris from entering the water system.

*b. Inspect and Service.* Inspect for bent or broken suction hose strainer, and the coupling-half (2) for stripped or damaged threads.



1 Coupling-half  
2 Strainer

*Figure 3-1. Suction strainer.*

### 3-7. Hose Assemblies

A 25-foot rubber suction hose assembly (fig. 3-2) is furnished with the bath unit to convey water from the water source to the water pump. Three 25-foot canvas hose assemblies (fig. 3-3) are furnished—one hose carries water from the water pump to the water heater and the other two hoses carry the warm water from the water heater to the two shower stands. The hoses are equipped with quick-coupling connections. On one end of each canvas hose, the connection consists of a coupler fitted with a gasket and two locking levers. The other end consists of an adapter with a shank. Each end of the rubber suction hose consists of a coupler with a gasket and two locking levers. The following instructions apply to the rubber and to the canvas hose assemblies.

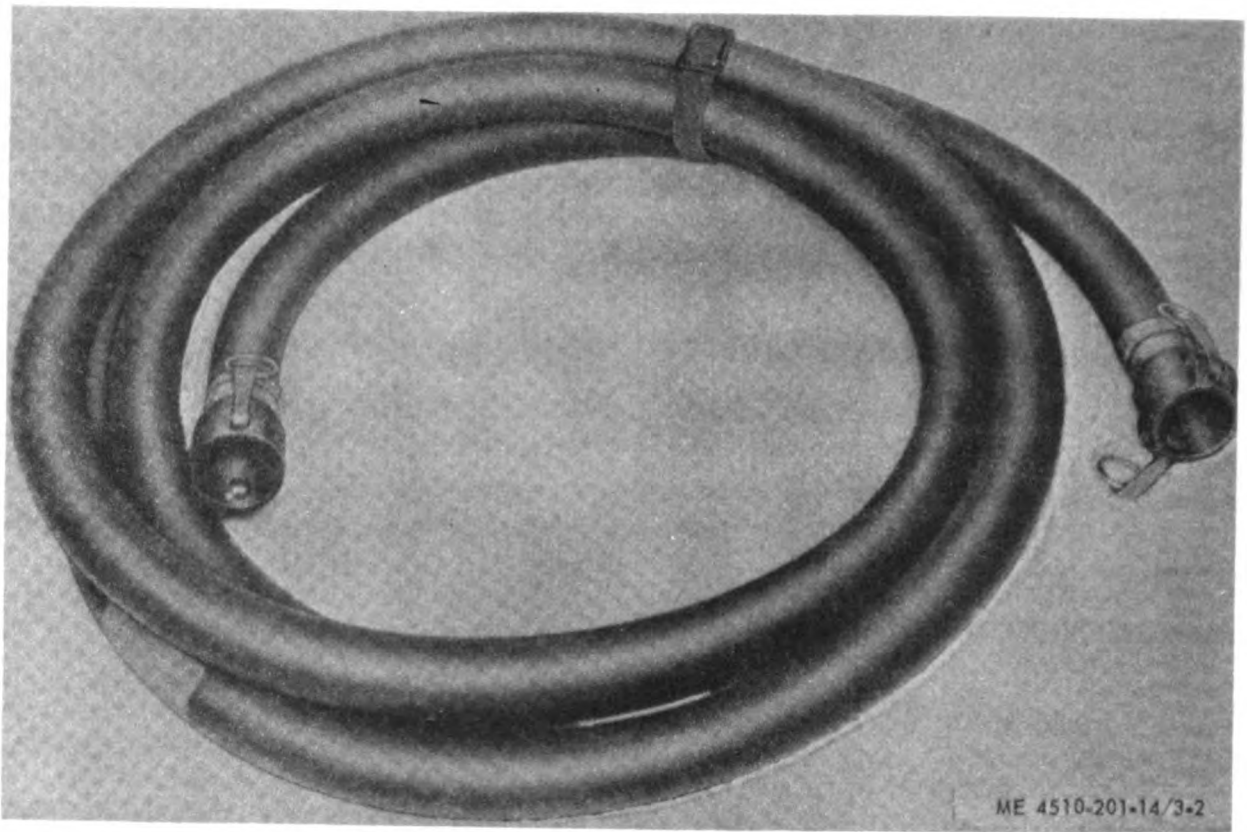
*a. Inspection.* Inspect the assembly for dirty,

cracked, broken, collapsed, and deteriorated hose; for broken or missing clamps; and for broken locking levers, couplers, adapters, and gaskets.

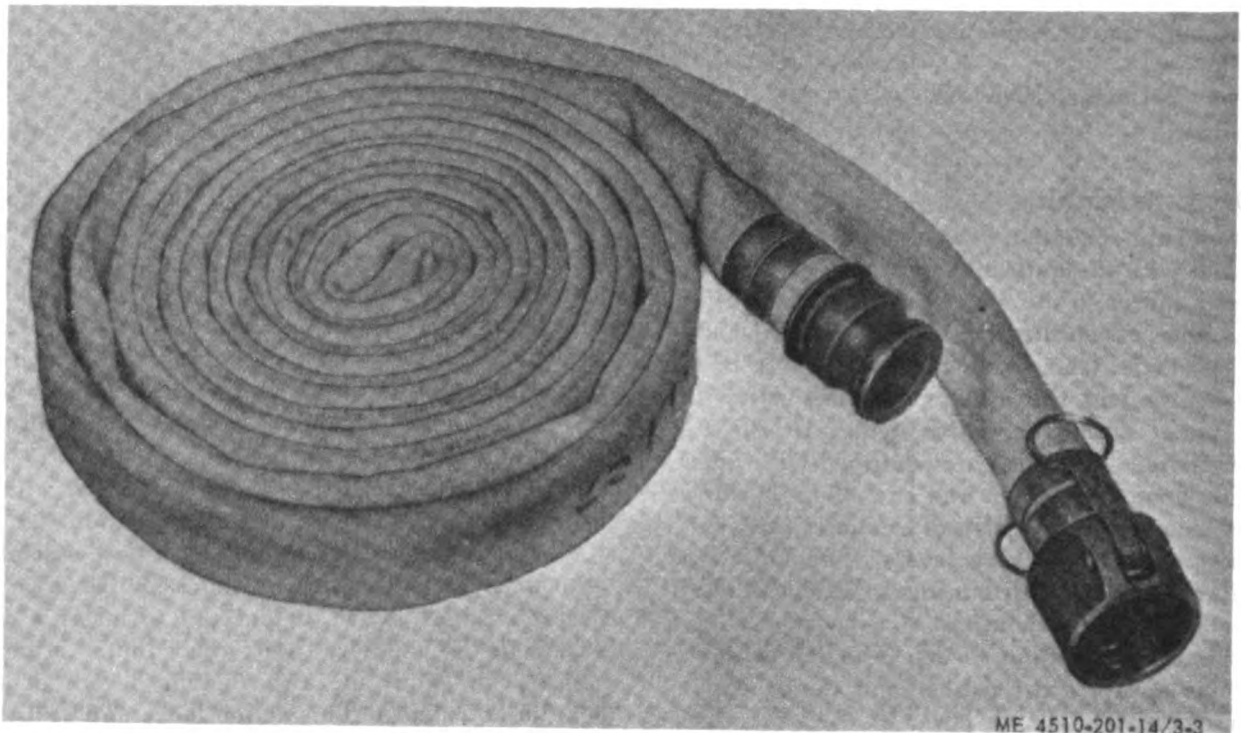
*b. Removal.* Disconnect the canvas hose assembly from the water heater and the water pump or from the water heater and the shower stand (as applicable). Disconnect the rubber hose assembly from the suction hose strainer and the water pump.

*c. Cleaning.* Scrub the hose assembly with a brush, using a mild, soapy-water solution.

*d. Installation.* Replace defective hose assembly with a serviceable one as authorized. Reverse the procedure in *b* above, being sure to insert a new gasket in the coupler. Insert the adapter into the coupler and pull the two locking levers of the coupler downward. This action locks and seals the coupler and the adapter, thus preventing leaks.



*Figure 3-2. Suction hose.*



*Figure 3-3. Shower stand and pump hoses.*

**3-8. Baseboard**

Use warm, soapy water to clean all dirt and oil from

the baseboard, including the straps, bolts, and capscrews.

## Section VI. MAINTENANCE OF SHOWER STAND AND WATER PUMP

### 3-9. General

This section describes maintenance functions of items which are listed in Group No. 02 of the MAC and which the operator must perform. Any deficiency which the operator is not authorized to correct must be reported as stipulated by TM 38-750.

### 3-10. Shower Head Nozzles

*a. Inspection.* Inspect the shower head nozzle (fig. 3-4 or 3-5) externally for clogged openings and loose mountings.

*b. Cleaning.*

(1) Clean the nozzle body (3, fig. 3-4) and the insert (2) used on Army models SPE 35 and SPE 35A, as follows:

(a) Unscrew and remove the body from the adapter (1), and remove the insert from the body.

(b) Clean all dirt and grit from the nozzle body and from the insert.

(c) Reverse the procedure in (a) above to assemble the nozzle, making certain the insert is

positioned properly and the nozzle body threads are not crossed on the adapter. Tighten the nozzle body securely.

(2) Clean the nozzle body (4, fig. 3-5) on Army models SPE 41, SPE 44, York-Shipley Model YS49279, and Army Model SPE 45 as follows:

(a) Unscrew and remove the body from the adapter (1). Remove the gasket (2) and the washer (3) from the body.

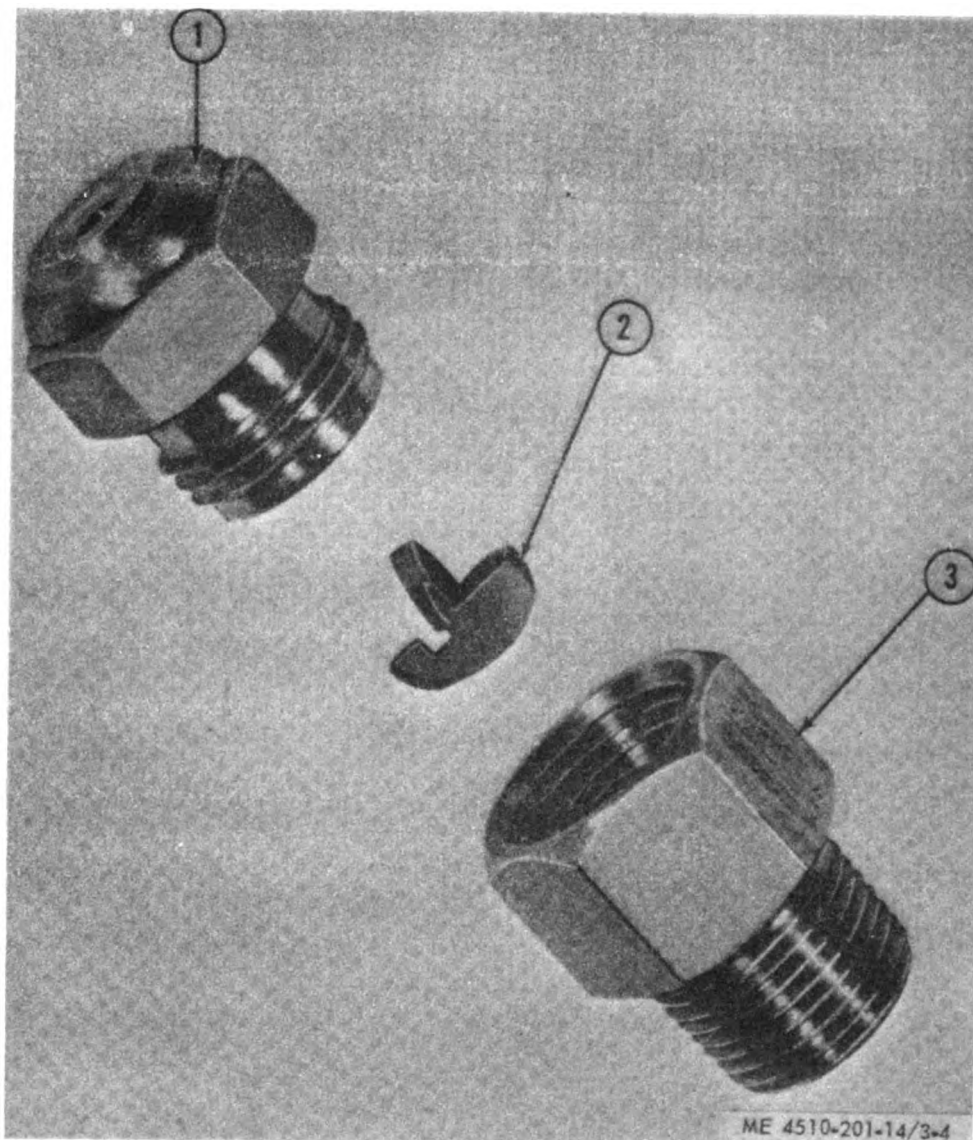
(b) Clean all dirt and grit from the nozzle body.

(c) Reverse the procedure in (a) above to assemble the nozzle, making certain the nozzle body threads are not crossed on the adapter. Hand tighten the nozzle body securely.

*c. Removal.* Unscrew and remove the complete nozzle (on any model) from the shower head and replace defective nozzle as authorized.

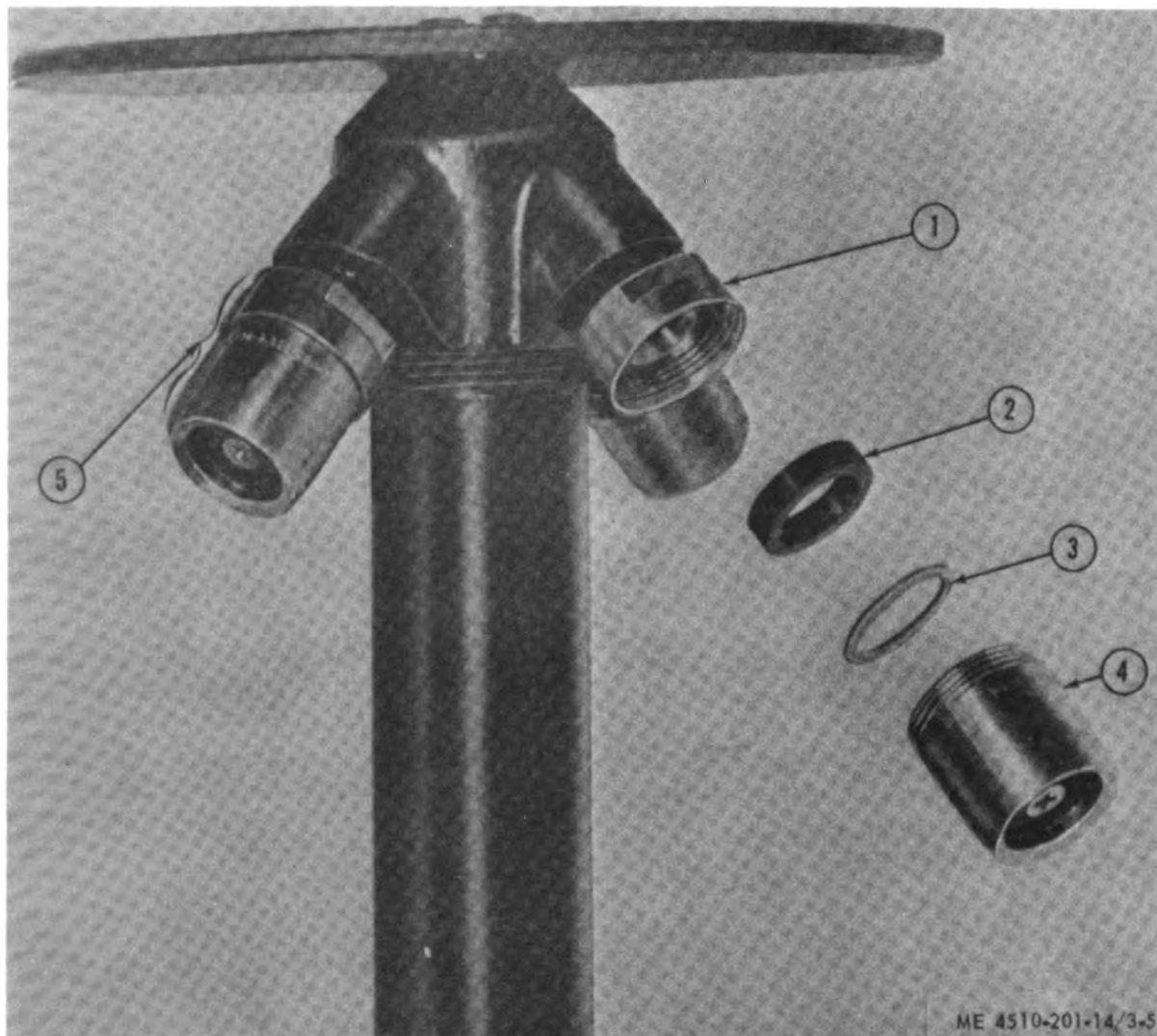
*d. Installation.* Reverse the procedure in c above.





- 1 Adapter
- 2 Insert
- 3 Body

**Figure 3-4. Shower head nozzle (used on Army models SPE 35 and SPE 35A) disassembled.**



- 1 Adapter
- 2 Gasket
- 3 Washer
- 4 Body
- 5 Nozzle

*Figure 3-5. Shower head nozzle (used on Army models 41, 44, 45 and York-Shipley model YS49279) disassembled.*

### 3-11. Water Line Strainer

*a. Inspection.* Inspect for dirty, broken, cracked, and leaking strainer. Inspect for leaking strainer cap.

*b. Cleaning.* Clean the strainer element after every 8 hours of operation of the water pump when the water source is a stream, lake, or river. It will not be necessary to clean the strainer element as often if the water source is an open reservoir that contains water from a pressurized source, or if the water has already been through a strainer. Remove the strainer element from its housing as in (1) through (5) below, clean it according to (6) below, and install it as in (7) below.

(1) Unscrew the locknut (6, fig. 3-6) several turns on the clamp screw (7).

(2) Loosen the clamp screw, allowing the clamp (5) to release from the flange on the strainer housing (1).

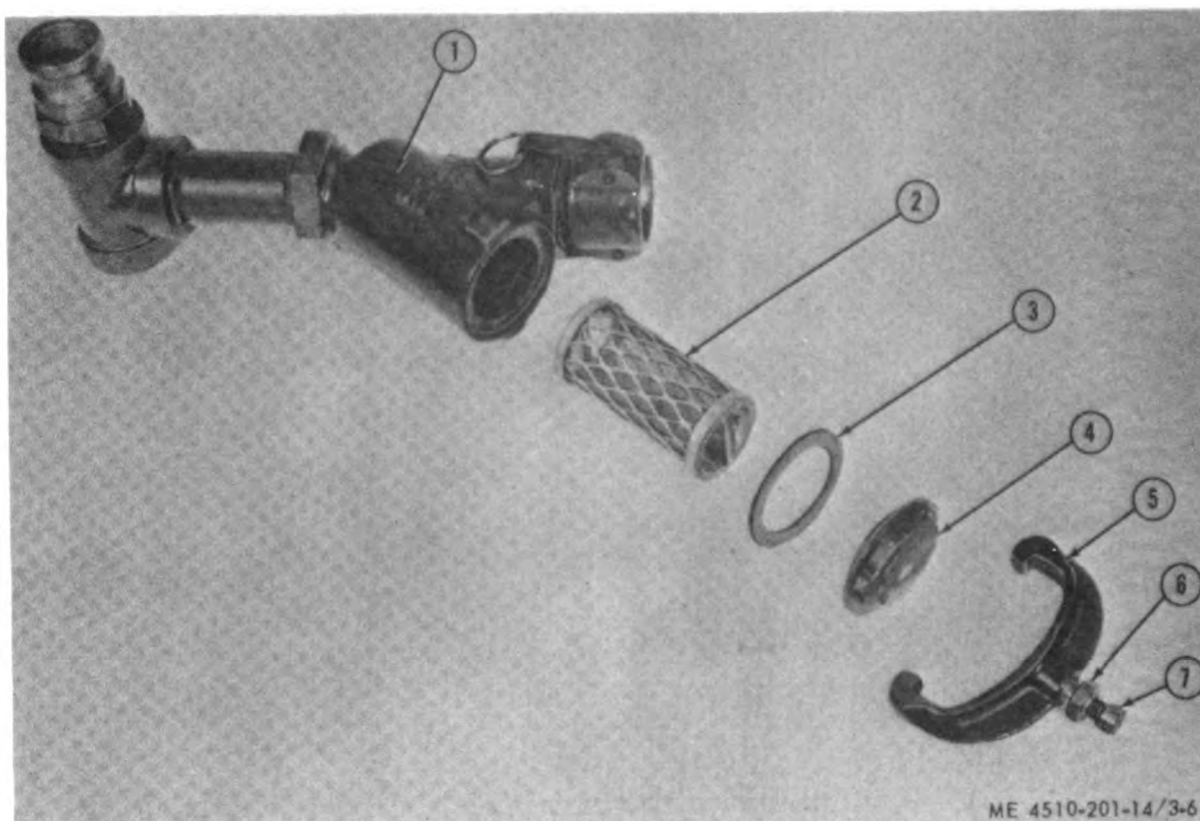
(3) Use the right hand to hold the strainer cap (4) in the housing, and then use the left hand to slide the clamp from the housing.

(4) Remove the strainer cap and the gasket (3) from the housing.

(5) Slide the strainer element (2) from the housing.

(6) Wash the element in clean water. Agitate it to remove all mud and dirt, and dry it with a clean cloth.

(7) Install the element by reversing the procedure in (1) through (5) above. Make certain the clamp screw (7) is tight before tightening the locknut (6).



- 1 Housing, strainer element
- 2 Element, sediment strainer
- 3 Gasket, line strainer cap
- 4 Cap, line strainer

- 5 Clamp, cap
- 6 Locknut
- 7 Screw, clamp

*Figure 3-6. Water line strainer.*

## CHAPTER 4

# ORGANIZATIONAL MAINTENANCE INSTRUCTIONS

### Section I. SERVICE UPON RECEIPT OF BATH UNIT

#### 4-1. General

When either a new or a used bath unit is received by an organization, the organizational personnel must inspect and service each component to prepare the bath unit for operation. The operator will assist the organizational personnel when he is directed to do so.

#### 4-2. Uncrating Bath Unit

The bath unit is packed and shipped in a wooden crate. The bottom of the crate is constructed to form a skid, as shown in figure 4-1, which can be used to slide the bath unit for short distances. The skid on which the bath unit is shipped is adaptable to handling the boxed or crated bath unit by either

slings or a forklift truck. Be careful when placing slings on the crate to make certain that the bath unit will balance evenly and properly and will be kept level when lifting it to the site to be uncrated. Uncrate the bath unit as follows:

a. Remove the lag screws securing the top to the sides of the packing crate, and remove the top from the crate.

b. Remove the lag screws securing the sides to the bottom of the crate, and remove the sides from the bottom as shown in figure 4-1.

c. Remove the nuts securing the baseboard to the bottom of the packing crate.

d. Remove the baseboard with bath unit from the bottom of the packing crate.

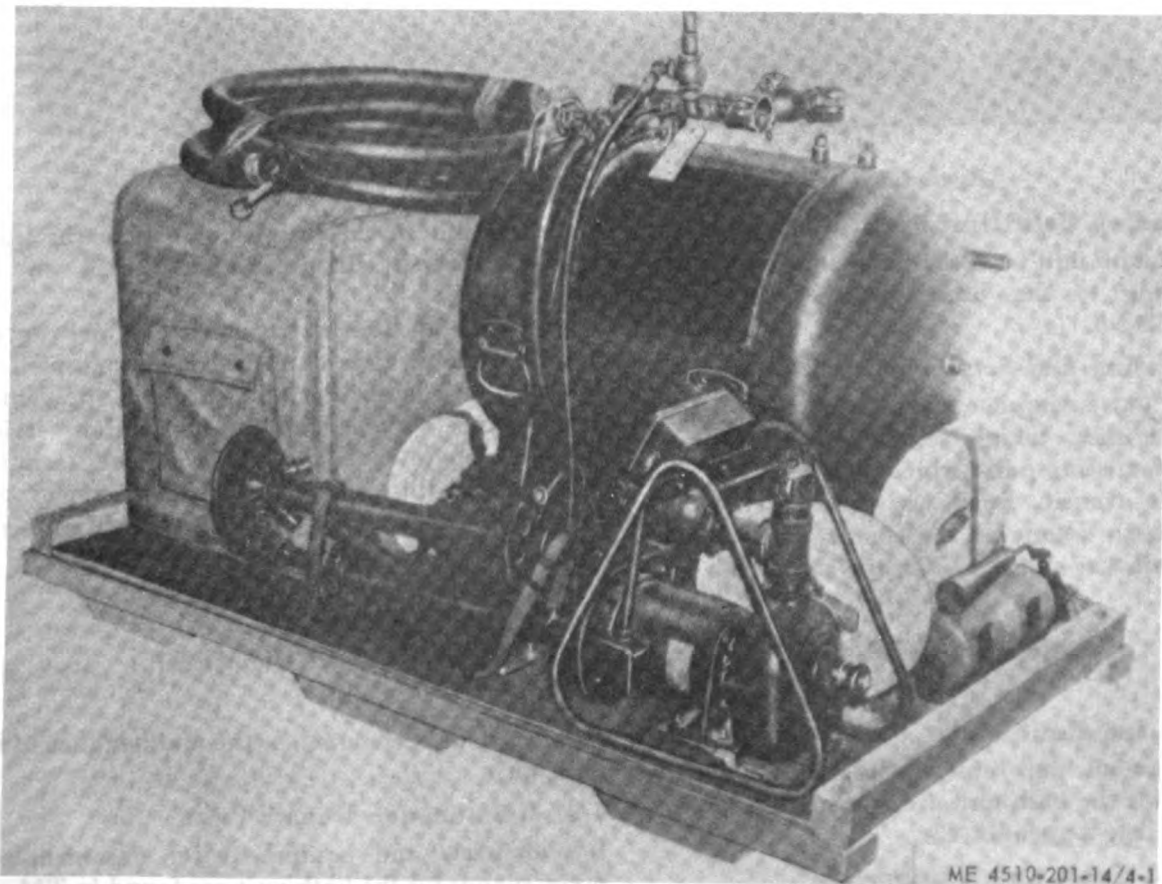


Figure 4-1. Bath unit with top and sides of crate removed.

### 4-3. Unpacking Bath Unit

a. Use extreme care when unpacking and installing separately packed components or items of equipment.

b. Remove all protective tape and materials used in packing the bath unit, including the water and fuel hose assemblies as shown in figure 4-2.

c. Check the components of the bath unit with the basic issue item list in appendix C to assure that bath unit is complete.

d. Remove with SD (solvent, drycleaning) the preservation compound which has been sprayed on all metal surfaces. Because this compound is not a lubricant, take special care to remove it completely from all wearing surfaces.

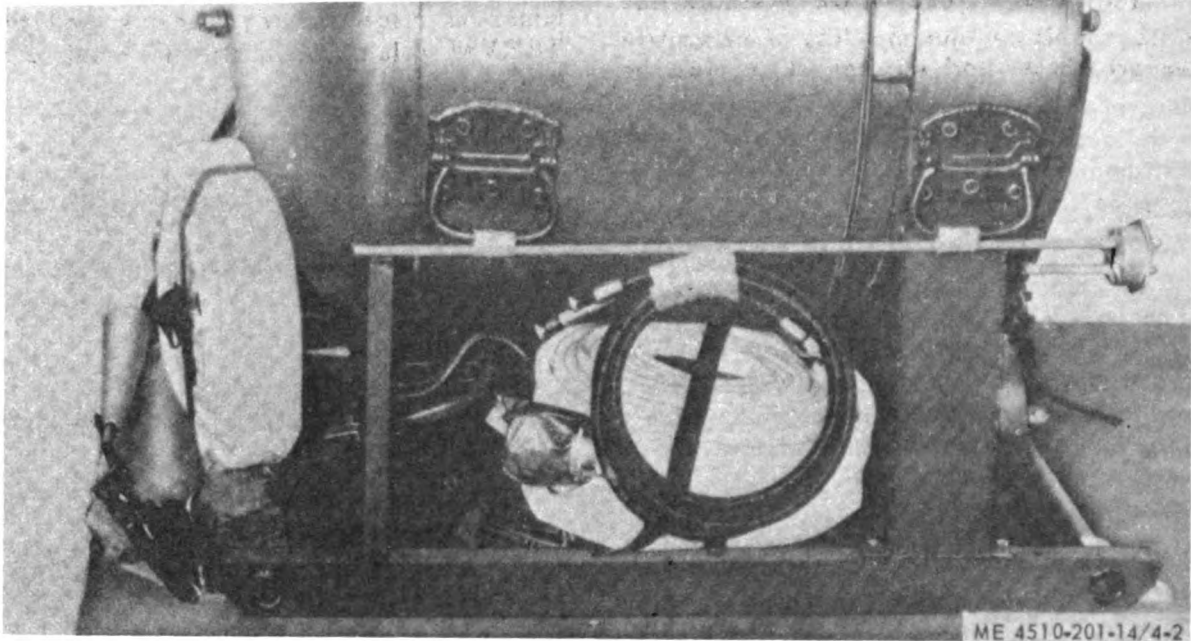


Figure 4-2. Hose assemblies mounted on water heater and baseboard.

### 4-4. Unloading Bath Unit From Baseboard

Unload the bath unit from the baseboard and set it up according to the procedures set forth in paragraph 2-2 b.

### 4-5. Inspecting and Servicing Bath Unit

a. Carry out a complete visual inspection of the overall bath unit, taking special notice of any damaged or missing parts which might have been sustained in transit. Read any warning on the shipping tag to determine the condition in which the bath unit was shipped. The tag should be at-

tached to one of the lifting handles on the water heater. Observe all precautions noted on the shipping tag.

b. Perform the organizational preventive maintenance services described in paragraph 4-10 for the bath unit. Perform also the preventive maintenance services and the lubrication services for the generator as described in the technical manual listed in appendix A. The services performed at this time will begin the cycle of regularly scheduled preventive maintenance services.

## Section II. REPAIR PARTS, SPECIAL TOOLS AND EQUIPMENT

### 4-6. Tools and Equipment

Tools, equipment, and repair parts issued with or authorized for the bath unit are listed in the basic issue items list, Appendix C.

### 4-7. Special Tools and Equipment

No special tools or equipment are required by

organizational personnel for the maintenance of the bath unit.

### 4-8. Maintenance Repair Parts

Repair parts and equipment for organizational maintenance for the bath unit are found in TM 10-4510-201-24P.

### **Section III. ORGANIZATIONAL PREVENTIVE MAINTENANCE CHECKS AND SERVICES**

#### **4-9. General**

For a general description and purpose of the preventive maintenance checks and services, refer to paragraph 3-1.

#### **4-10. Organizational Preventive Maintenance**

Table 4-1 contains a tabulated list of preventive maintenance checks and services which must be

performed by organizational maintenance personnel at quarterly intervals. A quarterly interval is equal to three calendar months or 250 hours of operation, whichever occurs first. The item number column of table 4-1 indicates the sequence of minimum inspection requirements, and the INTERVAL column designates the required service intervals.

Table 4-1. Preventive Maintenance Checks and Services.

Item number	Interval						Item to be Inspected	Procedure	Reference
	Operator			Org.					
	B	D	A	W	M	Q			
1							X Skid level	Inspect for broken, cracked or dirty level.	(para 4-31)
2							X Fuel pump and filter	Inspect for cracked and leaking pump and filter. Check for improper alinement and loose mounting of the pump and filter.	(para 4-41)
3							X Burner exhaust pipe	Inspect for broken and leaking exhaust pipe. Check inside the duct for any foreign matter or obstruction.	(para 4-18)
4							X Burner electrodes and nozzle	Inspect burner electrodes for improper spark and gap. Electrodes should be set for a 5/32-inch gap. Check burner nozzle for carbon deposits.	(para 4-33)
5							X Burner head and air hose	Inspect for broken and cracked burner head. Check for dirty and corroded air hose.	(para 4-33)
6							X Upper manifold relief valve (on Army Models 41, 44, 45, and York-Shipley Model YS49279)	Inspect for cracked, broken and leaking relief valve.	(para 4-34)
7							X Water heater tank.	Inspect for dented, broken, cracked, and leaking tank, upper and lower manifolds and instruction plate for broken welds. Inspect for cracked, broken, and corroded combustion chamber.	(para 4-38)
8							X Controls and instruments	Check for broken controls and instruments. During operation, check for looseness and binding. Normal operating temperatures and pressures for the instruments are as follows: Water temperature gage — 95° to 105° F. Fuel pressure gage — Low fire: 5 psi Medium fire: 60 psi High fire: 100 psi	(para 4-27 and 4-40)
9							X Electric motors	Inspect motors for loose mounting and any obstructions to ventilation.	(para 4-25 and 4-43)
10							X Water pump water line strainer <i>Note 1.</i> Ground Terminal  <i>Note 2.</i> Fire Extinguisher <i>Note 3.</i> Operational test  <i>Note 4.</i> Adjustment  <i>Note 5.</i> Suction hose strainer.	Inspect for cracked, broken, dirty, and corroded strainer. Before operational test, check for proper ground. A proper ground will consist of a 3/4 inch diameter hallow rod or a 5/8 inch diameter solid rod. The cable will be 6 AWG copper wire, bolted or clamped to the rod, and attached to the ground terminal of the generator set. Before operational test, inspect for broken seal.  Observe for any unusual noises or vibration during operational test. Check fuel line and water hose assemblies for leaking, electric motors for overheating and shower nozzles for improper spraying. Inspect fuel pump for proper pressure adjustment during operational test. Inspect for dirty strainer. Check for proper positioning of strainer during operational test.	(para 4-23)

## Section IV. TROUBLESHOOTING

### 4-11. General

For a general description and purpose of the troubleshooting table, refer to paragraph 3-3.

### 4-12. Organizational Troubleshooting

The troubleshooting table (table 4-2) is as follows:

Table 4-2. Troubleshooting

MALFUNCTION TEST OR INSPECTION	CORRECTIVE ACTION
<b>SHOWER STAND AND WATER PUMP ASSEMBLY</b>	
<b>1. SHOWER STAND NOZZLES NOT DISCHARGING ENOUGH WATER</b>	
Step 1. Check to see if water pump is worn excessively.	Install serviceable pump (para 4-26).
Step 2. Inspect for broken shower stand control valve.	Install serviceable valve (para 4-21).
Step 3. Check for leaking hose.	Repair hose (para 4-16).
Step 4. Check for clogged water line strainer.	Clean strainer (para 4-23).
<b>2. WATER PUMP FAILS TO DELIVER WATER</b>	
Step 1. Inspect for clogged impeller.	Remove pump body and clean impeller (para 4-26).
Step 2. Check for damaged impeller.	Install serviceable impeller (para 4-26).
Step 3. Check for reverse rotation.	Interchange any two of the external leads at the motor (para 4-25 d).
<b>3. WATER PUMP FAILS TO DEVELOP ENOUGH PRESSURE</b>	
Step 1. Inspect for leaking shaft seals.	Replace the seals (para 4-26 e).
Step 2. Inspect for broken impeller.	Install serviceable impeller (para 4-26).
<b>4. WATER PUMP FAILS TO ROTATE</b>	
Step 1. Check for dirty or clogged impeller.	Clean impeller.
Step 2. Check to see if electric motor is operating.	Check electrical connections or install serviceable motor (para 4-25).
<b>5. PULSATING PRESSURE ON WATER DISCHARGING FROM SHOWER STANDS</b>	
Step 1. Check for excessively worn pump.	Check pump prime. If pump will not stay primed install serviceable pump (para 4-26 e).
<b>6. WATER PUMP NOISY</b>	
Step 1. Check for excessively worn motor bearings.	Install serviceable water pump motor (para 4-26).
Step 2. Check for dirty impeller.	Clean impeller (para 4-26 d).
Step 3. Check for excessively worn or broken impeller.	Install serviceable impeller (para 4-26).
<b>WATER HEATER ASSEMBLY</b>	
<b>1. FUEL PRESSURE TOO LOW ON GAGE</b>	
Step 1. Check for excessively worn burner control valve.	Install serviceable valve (para 4-40 i).
Step 2. Check fuel pump for proper adjustment.	Adjust pump pressure (para 4-41 a (5)).
Step 3. Check for dirty or clogged fuel filter.	Clean filter (para 4-41 c).
<b>2. FUEL PRESSURE TOO HIGH ON GAGE</b>	
Step 1. Check for defective pressure gage.	Install serviceable gage (para 4-40 j).
Step 2. Check fuel pump for proper adjustment.	Adjust pump pressure (para 4-41 a (5)).



Table 4-2. Troubleshooting (Cont'd).

MALFUNCTION	TEST OR INSPECTION	CORRECTIVE ACTION
<b>WATER HEATER ASSEMBLY—Continued</b>		
<b>3. PULSATING PRESSURE INDICATED ON GAGE</b>	Step 1. Check for clogged fuel pump strainer.	Remove and clean strainer (para 4-41b).
	Step 2. Check for clogged fuel filter.	Clean filter (para 4-41c).
	Step 3. Check for defective burner nozzle.	Replace nozzle (para 4-33).
<b>4. FUEL PUMP LEAKS</b>	Step 1. Check for loose strainer cover.	Tighten all cover screws.
	Step 2. Check for loose plugs.	Tighten plugs.
	Step 3. Check for broken or excessively worn shaft seals.	Install serviceable pump (para 4-41).
<b>5. FUEL PUMP FAILS TO DELIVER FUEL TO BURNER</b>	Step 1. Check for clogged fuel pump strainer.	Remove and clean strainer (para 4-41b).
	Step 2. Check for clogged fuel nozzle.	Remove and clean nozzle (para 4-33d (2)).
	Step 3. Check for reversed rotation.	Interchange any two of the external leads at the motor (para 4-43).
	Step 4. Check for improper installation of fuel pump.	Check installation. If improperly installed, remove and install pump properly (para 4-41).
	Step 5. Check for broken solenoid valve.	Install serviceable valve (para 4-40i).
	Step 6. Check for loose fuel pump drive coupling.	Tighten coupling (para 4-41f).
<b>6. FLAME FAILS IN BURNER</b>	Step 1. Check for excessively worn or broken fuel pump.	Install serviceable pump (para 4-41a).
	Step 2. Check for clogged fuel line.	Clean fuel line (paras 4-41 and 4-42).
	Step 3. Check for clogged fuel nozzle.	Remove and clean nozzle (para 4-33d (2)).
	Step 4. Check for burned electrodes.	Clean electrodes (para 4-33d (1)).
	Step 5. Check electrodes for proper adjustment.	Adjust electrodes (para 4-33e).
<b>7. IGNITION TRANSFORMER HAS NO SPARK</b>	Step 1. Check transformer wiring for open or shorted circuit.	Install serviceable transformer (para 4-30 and para 6-7).
	Step 2. Check for disconnected transformer-to-cable assembly.	Connect cable (para 4-30).
<b>8. IGNITION TRANSFORMER HAS FAULTY OR WEAK SPARK</b>	Step 1. Check for loose transformer-to-burner cable assembly.	Seat cable firmly and securely in transformer cover (para 4-30).
<b>9. SMOKE ESCAPING AROUND BOILER BOX COVER</b>	Step 1. Check for deteriorated or excessively worn gasket.	Install serviceable gasket (para 4-32).
<b>10. WATER OVERHEATS</b>	Step 1. Check pressure and temperature control for proper operation (para 6-10).	Install serviceable control (para 4-40f).
<b>11. WATER HEATS INCONSISTENTLY</b>	Step 1. Check firebox for carbon deposits.	Remove boiler box cover (para 4-32) and clean smokebox.
<b>12. BLOWER AND FUEL PUMP MOTOR NOISY</b>	Step 1. Check for excessively worn bearings.	Install serviceable motor (para 4-43).

## Section V. MAINTENANCE OF MISCELLANEOUS ITEMS

### 4-13. General

This section describes the organizational maintenance instructions for the miscellaneous items listed in group 01 for the bath unit. These items include the bath unit baseboard and straps; and the shower stand head, guard, riser, flow control valve, reducing couplings, and pipe nipples. Unless otherwise specified, the following instructions in this section apply generally to the items used for all five Army models SPE 35, SPE 35A, SPE 41, SPE 44, SPE 45 and York-Shibley Model YS49279. Any differences will be so specified in the applicable paragraphs, by the particular Army model number. The organizational maintenance instructions for the generator sets are given in the applicable technical manuals listed in appendix A. Any deficiencies which the organizational maintenance personnel are not authorized to correct must be reported as stipulated in TM 38-750.

### 4-14. Generator Receptacle Box Cable, Condulet, Cover and Receptacle Connectors

#### a. Removal.

(1) Remove the nuts (8, fig. 4-3) that hold the condulet from the generator frame.

(2) Disconnect the wires in the cable (6) from the generator.

#### NOTE

Tag the wires for identification if color-coded wires are not used.

(3) Remove the four screws that attach each of the covers (1 and 3) to the condulet, and remove the covers and the gaskets from the condulet.

(4) Remove the two screws that secure the connectors (7 and 9) to the condulet, and lift the connectors from the condulet.

#### NOTE

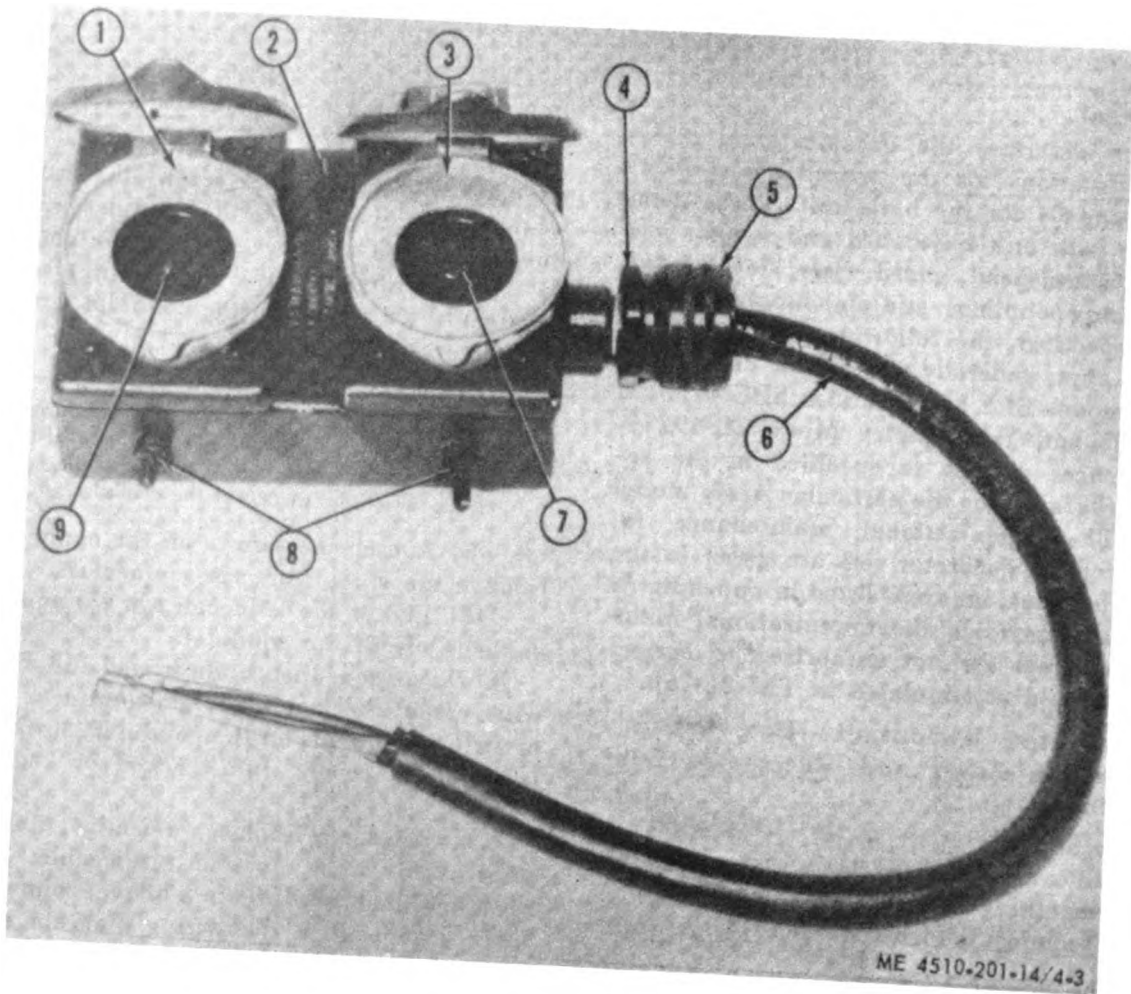
Some bath units come equipped with connectors fastened to the hinged lift covers. Removal is the same with the exception of removing the screws from the covers in lieu of the condulet.

(5) Loosen the screws on the connectors and remove the wires from the connectors.

(6) Loosen the connector nut (5) and slide the cable (6) from the condulet.

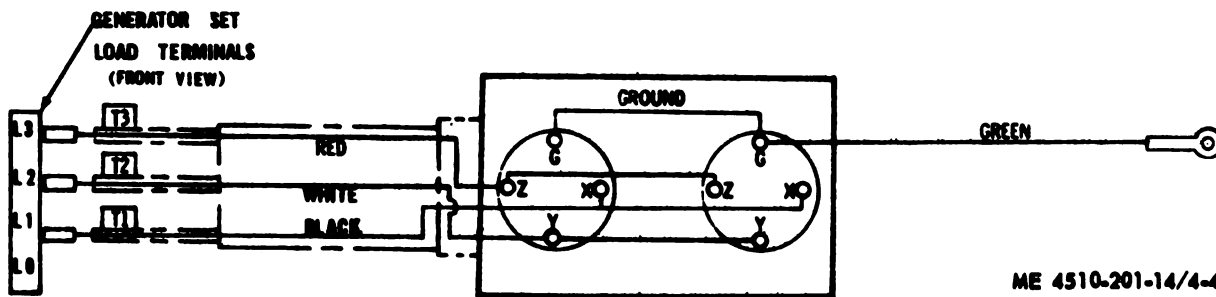
*b. Inspection.* Inspect for frayed and excessively worn cable; cracked or broken condulet; damaged or stripped threads on the condulet; broken hinge springs and cover; and cracked or broken connectors.

*c. Installation.* Replace defective items with serviceable ones. Install serviceable ones by reversing the procedure in a above, connecting the wires according to the wiring diagram shown in figure 4-4.



- 1 Cover
- 2 Conduit
- 3 Cover
- 4 Connector, electrical
- 5 Nut, connector
- 6 Cable, receptacle
- 7 Connector, electrical receptacle
- 8 Nuts
- 9 Connector, electrical receptacle

*Figure 4-3. Generator receptacle box with cable.*



ME 4510-201-14/4-4

Figure 4-4. Wiring diagram of generator receptacle box.

#### 4-15. Suction Strainer

a. *Description, Inspection and Service.* Refer to paragraph 3-6.

b. *Removal.* Remove the strainer with the coupling-half (1, fig. 3-1) from the water pump discharge hose assembly. Unscrew and remove the coupling-half from the strainer.

c. *Installation.* Replace defective strainer and coupling-half with serviceable ones, and install them by reversing procedures in a above.

#### 4-16. Hose Assemblies

##### NOTE

This paragraph applies to both the suction hose and to the shower stand and pump hoses.

a. *Removal, Inspection, Servicing and Installation.* Refer to paragraph 3-7.

b. *Repair.* The repair of the hose assemblies is limited to the replacement of the coupler or adapter

and hose clamps, and the relocation of the coupler or the adapter.

(1) *Replacement of Coupler or Adapter and Clamps.* If the hose has punch-lock-type clamps (bands), pry up the clamps enough to insert tin shears; then cut both clamps. Remove the clamps from the hose. Pull coupler with gasket or adapter from the hose. Remove worm-drive-type clamps from the hoses by loosening the screws on the clamps and pulling the coupler with gasket or the adapter from the hose. Install hose clamps on the hose, making certain the screw heads face in the same direction. Install coupler with a new gasket or an adapter into the hose end as far as it will go. Tighten the screws, making sure the clamps are around the hose securely.

(2) *Relocation of Coupler or Adapter.* If the hose is leaking at any point within 2 feet of the coupler or adapter, cut off the defective length of

hose, and move the coupler or adapter back. To accomplish this, proceed as follows:

(a) Place a mark around the hose about 3 inches behind the leak.

(b) Use the mark as a guide and cut the hose with a sharp knife, making the cut smooth and even.

(c) Remove the coupler with gasket or the adapter and the clamps from the damaged length of hose ((1) above).

(d) Install the coupler with gasket or the adapter and the clamp on the serviceable length of hose ((1) above).

#### 4-17. Baseboard

a. *Description.* The baseboard (7, fig. 4-5) is used to support the entire bath unit during transit and storage. The retaining straps (2 and 4) are used to hold the water heater, water pump and shower stands to the baseboard during transit and storage.

b. *Servicing and Repair.* For service information, refer to paragraph 3-8. For repair information, refer to paragraph 6-2.

##### c. *Removal.*

(1) Refer to paragraph 2-2 b and remove all bath unit equipment from the baseboard.

(2) Remove the capscrews that hold the water heater skid retaining straps (2) to the baseboard (7), and remove the straps.

(3) Remove the nuts, washers, and bolts that

hold the water pump frame retaining straps (4) to the baseboard, and remove the straps.

(4) Remove the water pump frame capscrew (5) that holds the water pump to the baseboard.

(5) Remove the nuts, washers, and bolts that hold the shower stand holddown straps (6) to the baseboard, and remove the straps.

(6) Remove the two screws that hold the fire extinguisher bracket (3) to the baseboard, and remove the bracket.

##### d. *Inspection.*

(1) Inspect for torn, deteriorated, and frayed shower stand holddown straps (6), and check the straps for broken or missing buckles.

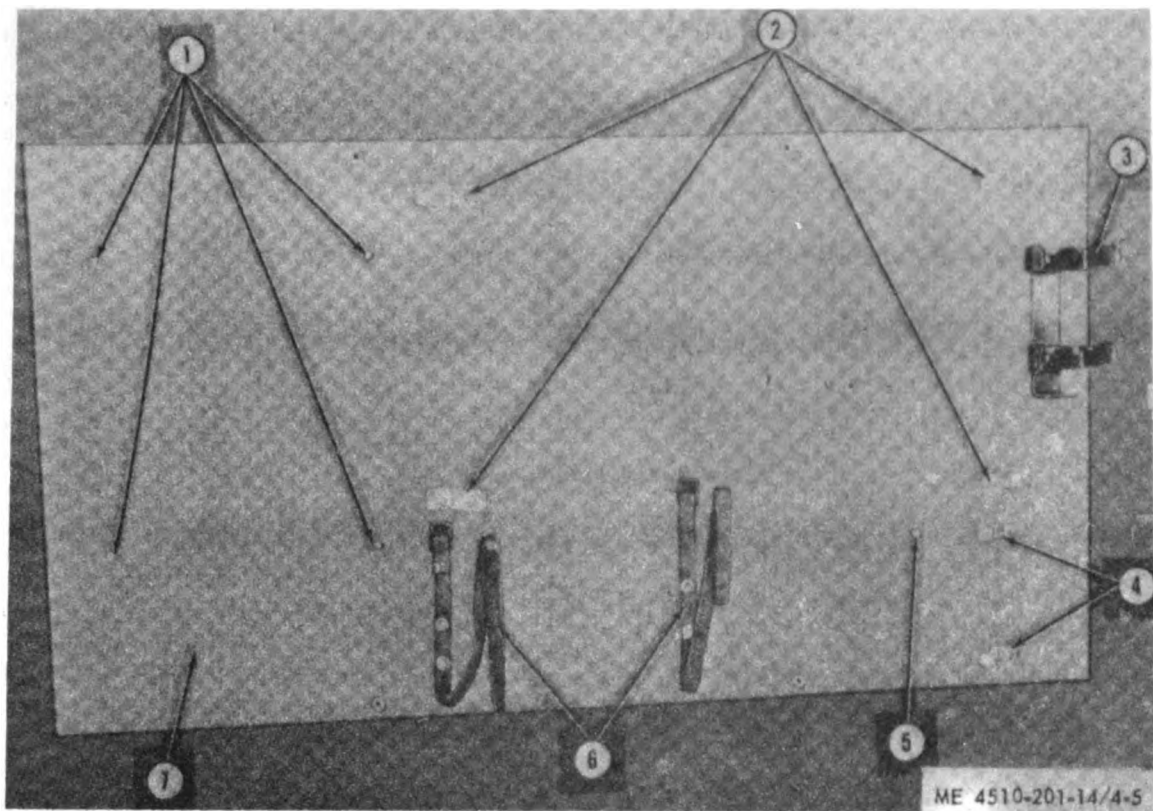
(2) Inspect for bent or damaged retaining straps (2 and 4).

(3) Inspect for bent or damaged fire extinguisher bracket (3).

(4) Inspect for cracked and broken baseboard and check for any gouged-out portions in the baseboard. Inspect the baseboard for any indication of warping or separating of the plies. Make certain the paint is not flaking or peeling on the baseboard.

(5) Inspect for damaged or stripped threads on the bolts, nuts, and capscrews.

e. *Installation.* Replace defective baseboard and straps with serviceable ones, and install them by reversing the procedure in c above. Use the old baseboard as a template for drilling of the replacement baseboard.



- 1 Capscrews, generator set mounting
- 2 Straps, water heater skid retaining
- 3 Bracket, fire extinguisher
- 4 Straps, water pump frame retaining
- 5 Capscrew, water pump frame
- 6 Straps, shower stand holddown
- 7 Baseboard, bath unit

Figure 4-5. Bath unit baseboard and straps.

#### 4-18. Burner Exhaust Duct

*a. Description.* The burner exhaust duct is installed in the lower left end of the water heater. It carries the exhaust fumes away from the heater.

*b. Inspection.* Inspect for broken and leaking exhaust duct (fig. 4-6). Inspect the exhaust duct for loose connections. Be sure there is no obstruction in the duct.

*c. Servicing.* Clean any obstruction from the duct.

*d. Removal.* Twist the exhaust duct to the left, and remove it from the opening in the water heater.

*e. Installation.* Replace defective duct with a serviceable one, and install it by reversing the procedure in *d* above.

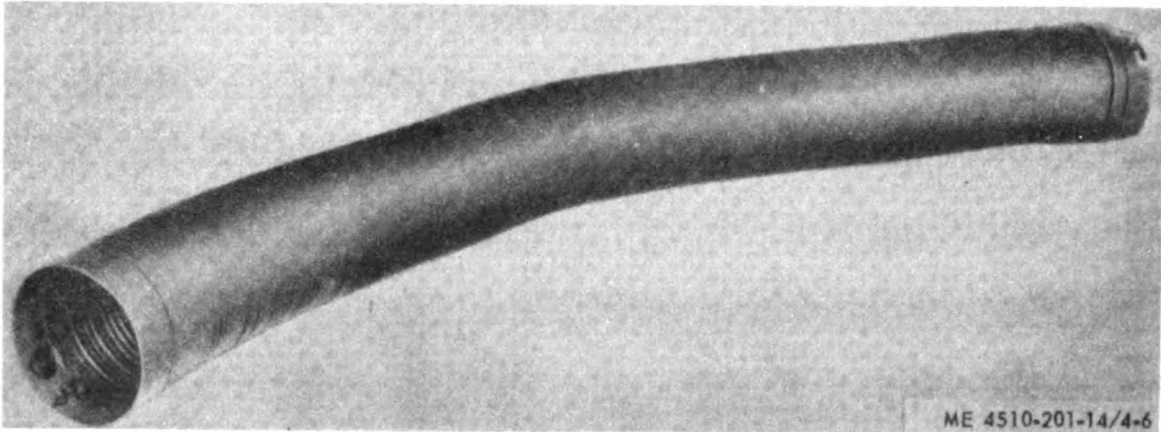


Figure 4-6. Burner exhaust duct.

## Section VI. MAINTENANCE OF SHOWER STAND ASSEMBLY

### 4-19. Shower Stand

a. *Nozzles.* Refer to paragraph 3-10.

b. *Head Guard (Used on Army Models SPE 41, SPE 44, SPE 45 and York-Shipley Model YS49279).*

(1) *Description.* The head guard (1, fig. 4-7), mounted on the shower stand head (2), is used to protect the four nozzles from being damaged.

(2) *Removal.* Remove the machine screws and the lockwashers that attach the guard (1) to the shower stand head (2), and remove the guard from the head.

(3) *Inspection.* Inspect for broken or cracked guard.

(4) *Installation.* Replace defective guard with a serviceable one, and install it by reversing the procedure in b (2) above.

c. *Shower Stand Head.*

(1) *Description.* The shower stand head (2), mounted on top of the riser (4), serves as a water port and a mount for the four nozzles.

(2) *Removal.*

(a) Unscrew and remove the four shower head nozzles (3) from the shower stand head.

(b) Remove the guard (b (2) above).

(c) Unscrew and remove the shower stand head (2) from the shower stand riser.

(3) *Inspection.* Inspect for cracked or bent head, and check for clogged nozzle openings. Inspect the nozzle openings for damaged threads.

(4) *Installation.* Replace defective head with a serviceable one, and install it by reversing the procedures in c (2) above.

d. *Shower Stand Leg.*

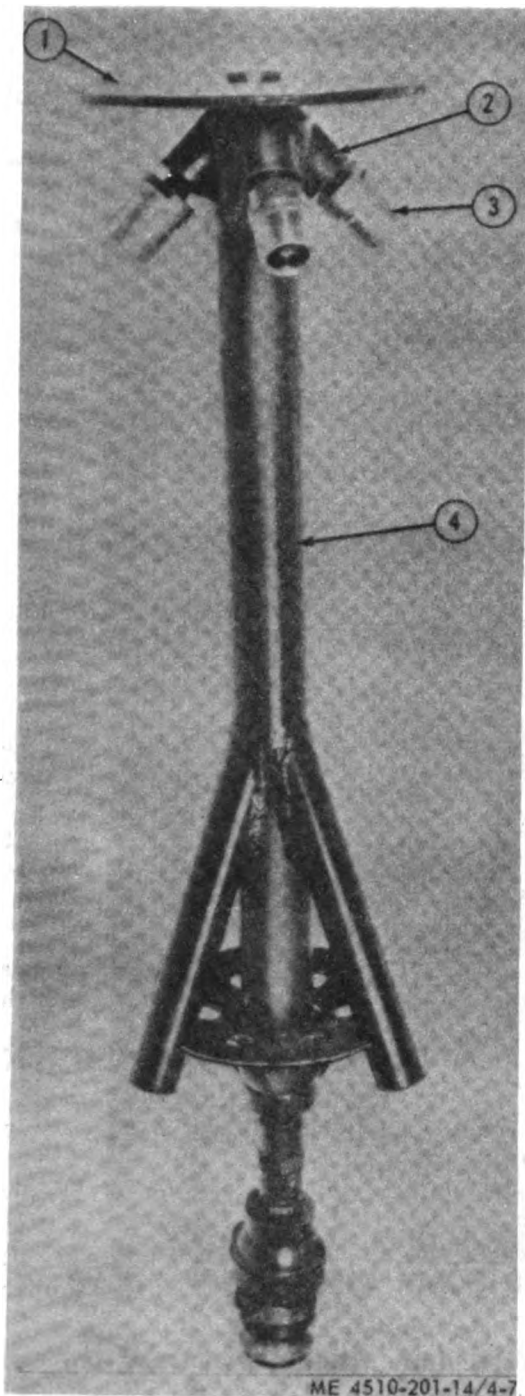
(1) *Description.* Each shower stand has three legs which are inserted in the riser to support the shower stand during operation.

(2) *Inspection.* Inspect for dirty, dented, cracked or bent leg.

(3) *Servicing.* Use a clean cloth to wipe any dirt from leg.

(4) *Removal.* Pull the leg from the shower stand riser (4).

(5) *Installation.* Replace a defective leg with a serviceable one, and install it by reversing the procedure in d (4) above.



- 1 Guard
- 2 Head
- 3 Nozzle
- 4 Riser

Figure 4-7. Shower stand riser.

#### 4-20. Riser

##### a. Removal.

(1) Remove the shower stand head from the riser (para 4-19 c(2)).

(2) Remove the upper reducing coupling (1, fig. 4-8), with the control valve(s) from the riser. Coupling is used on Army models SPE 41, SPE 44, SPE 45 and York-Shipley Model YS49279.

(3) Unscrew and remove the adapter from the riser (On Army models SPE 35 and SPE 35A).

(4) Pull the shower stand legs from the riser (4, fig. 4-7).

b. *Inspection.* Inspect for dented and broken riser. Inspect the riser and the soap tray for clogged openings. Make certain that leg sockets are not dirty. Check welds for cracks or breaks.

c. *Installation.* Replace defective riser with a serviceable one, and install it by reversing the procedure in a above.

d. *Repair.* Refer to paragraph 6-4.

#### 4-21. Flow Control Valve, Reducing Couplings and Nipples (Used on Army Models SPE 41, SPE 44, SPE 45 and York-Shipley Model YS49279)

a. *Description.* The shower stand flow control valve (3, fig. 4-8) is located at the bottom of the riser between the two reducing couplings (1 and 5). It restricts or controls the amount of water flowing to the shower head, thereby allowing the shower spray to remain constant.

##### b. Removal.

(1) Unscrew and remove the adapter (6) from the lower reducing coupling (5).

(2) Unscrew and remove the reducing coupling from the lower pipe nipple (4).

(3) Unscrew and remove the lower nipple from the flow control valve (3).

(4) Unscrew and remove the flow control valve from the upper pipe nipple (2).

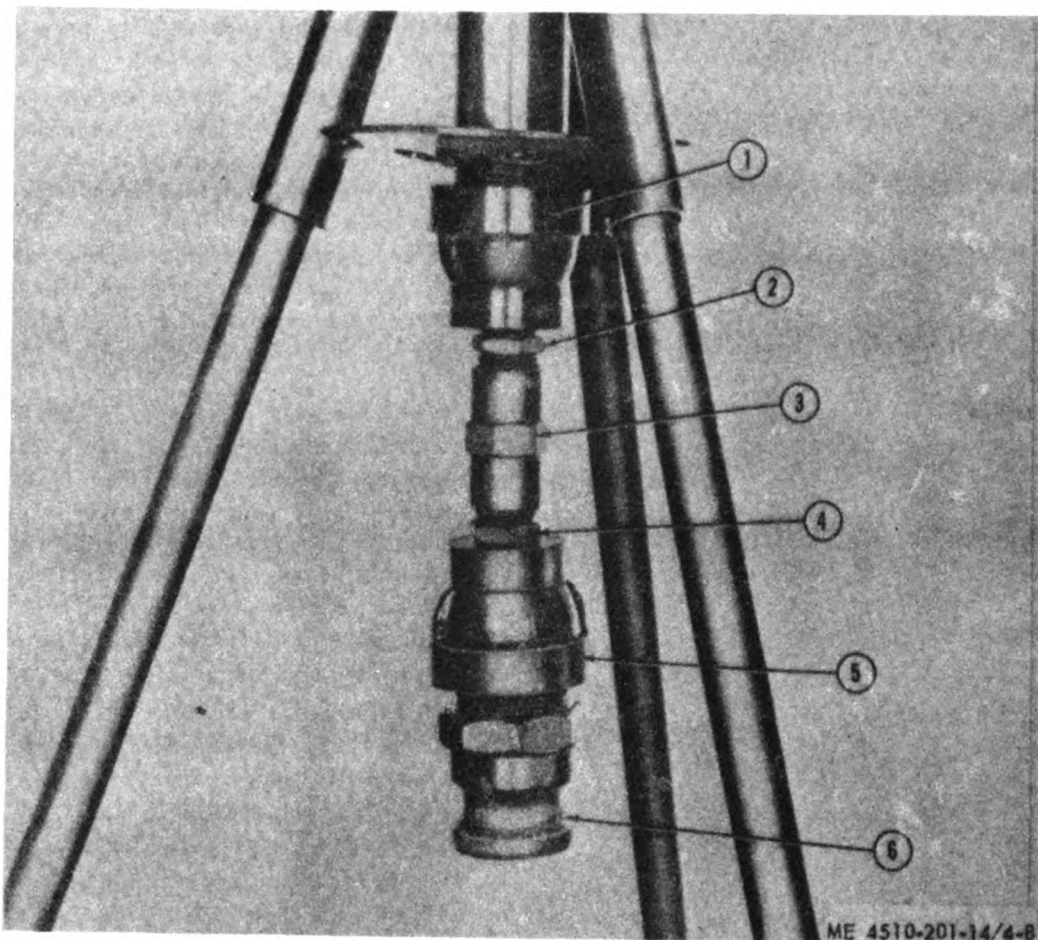
(5) Unscrew and remove the upper pipe nipple (2) from the upper reducing coupling (1).

(6) Unscrew and remove the reducing coupling from the shower stand riser.

c. *Inspection.* Inspect for bent or cracked couplings and nipples, and inspect for damaged threads on the couplings and nipples.

d. *Installation.* Replace defective couplings, flow control valve and nipples with serviceable ones. Install them by reversing the procedure in b above, making certain the flow control valve is installed with the arrow pointing in the direction of the flow of water.





- 1 Coupling, reducing
- 2 Nipple, pipe
- 3 Valve, flow control
- 4 Nipple, pipe
- 5 Coupling, reducing
- 6 Adapter

*Figure 4-8. Shower stand flow control valve (Used only on Army models SPE 41, 44, 45 and York-Shibley model YS49279).*

## Section VII. MAINTENANCE OF WATER PUMP ASSEMBLY

### 4-22. General

This section describes the organizational maintenance instructions for the items or components of the water pump listed in group 02. The following instructions in this section apply generally to the items or components used for all five Army models SPE 35, SPE 35A, SPE 41, SPE 44, SPE 45 and York-Shibley model YS49279—no different instruction is necessary for a particular model. Any deficiencies which the organizational maintenance personnel are not authorized to correct must be reported according to the instructions in TM 38-750.

### 4-23. Water Line Strainer and Dust Cap

#### a. Description.

(1) The water line strainer is located on the discharge side of the pump. It prevents any foreign matter larger than the shower head nozzle orifice from entering the water heater.

(2) *Dust cap.* The dust cap is located on the prime port of the water pump.

*b. Inspection, Cleaning and Replacing Strainer Cap, Clamp, Dust Cap and Strainer Element.* Refer to paragraph 3-11 and fig. 4-9, and replace components as necessary.

**c. Removal of Strainer.**

(1) Remove the electrical motor and the pump from the pump frame (para 4-24).

(2) Remove the coupler (1, fig. 4-9) from the water line strainer (3).

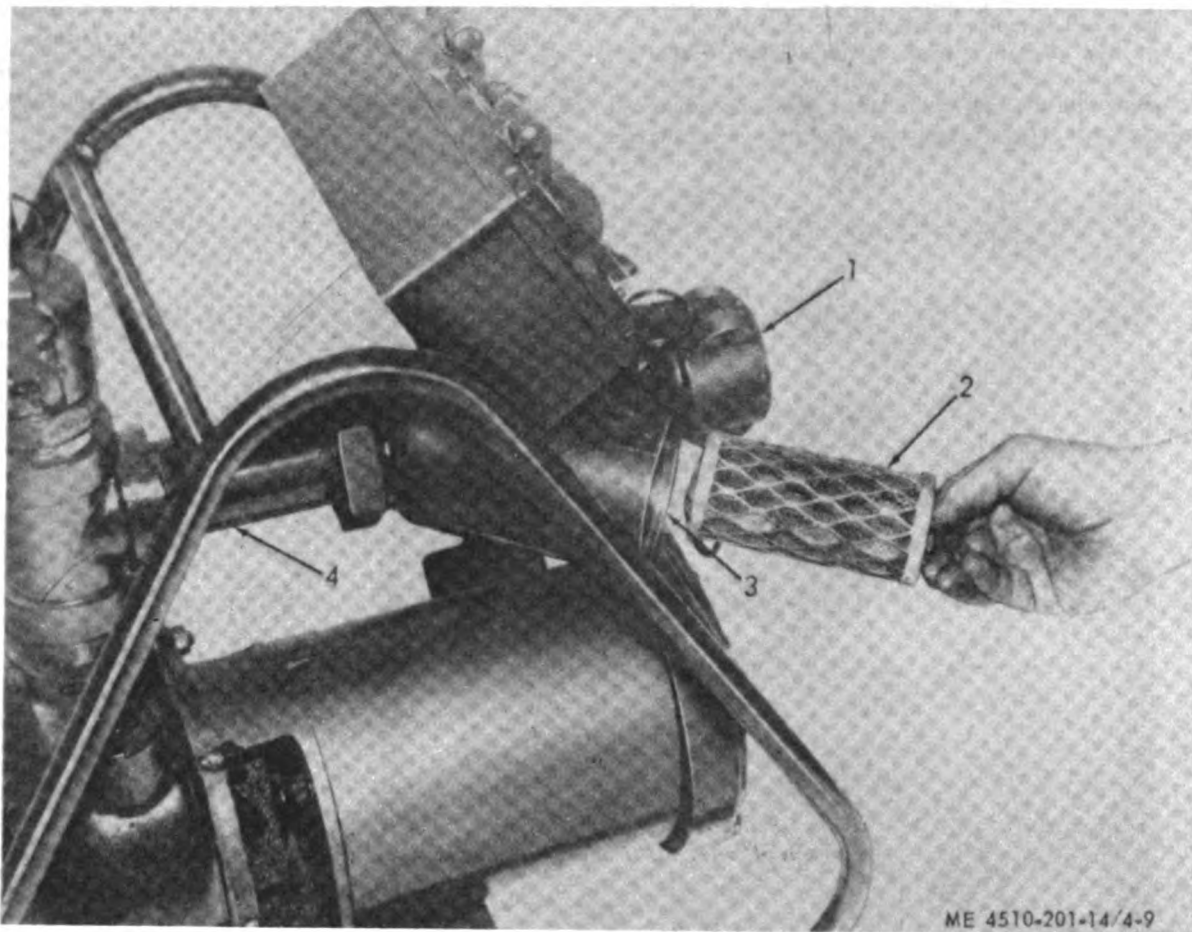
(3) Unscrew and remove the sediment strainer from the pipe nipple (4).

**d. Removal of Dust Cap.**

(1) Pull the locking levers downward and remove the dust cap with gasket from the adapter.

(2) Remove the gasket from the dust cap.

**e. Installation.** Replace defective strainer or dust cap with gasket with a serviceable one, and install them by reversing the procedures in c and d above.



- 1 Coupler
- 2 Element
- 3 Strainer
- 4 Nipple, pipe

*Figure 4-9. Strainer element, removed from water line strainer.*

**4-24. Water Pump Frame**

**a. Description.** The tubular-type frame is used to mount and to support the water pump and the electric motor.

**b. Inspection.** Inspect for bent, broken, and distorted frame.

**c. Repair.** Refer to paragraph 6-5.

**d. Removal.**

(1) Remove the nuts (6, fig. 4-10) and the capscrews that hold the bracket (5) to the pump frame (1).

(2) Remove the two screws that hold the cover to the electrical connector box (5, fig. 4-11).

(3) Remove the wire nuts (4) from the wire connections, and disconnect the wires that run from the control panel box (2) to the electrical connector box.

**NOTE**

Tag the wires for identification if color-coded wires are not used.

(4) Remove the nut (6) from the connector that holds the conduit tube (7) to the electrical connector box.

(5) Remove the screws (3) that hold the electrical connector box to the electric motor, and remove the box from the motor.

(6) Remove the motor and the pump with the pipe connections from the frame.

**NOTE**

Electric motors furnished with some of the bath units and as replacements differ in that they have no box affixed to them for making the motor connections. These motors have a conduit elbow going into the side of the motor and connections are made through the access plate located on the

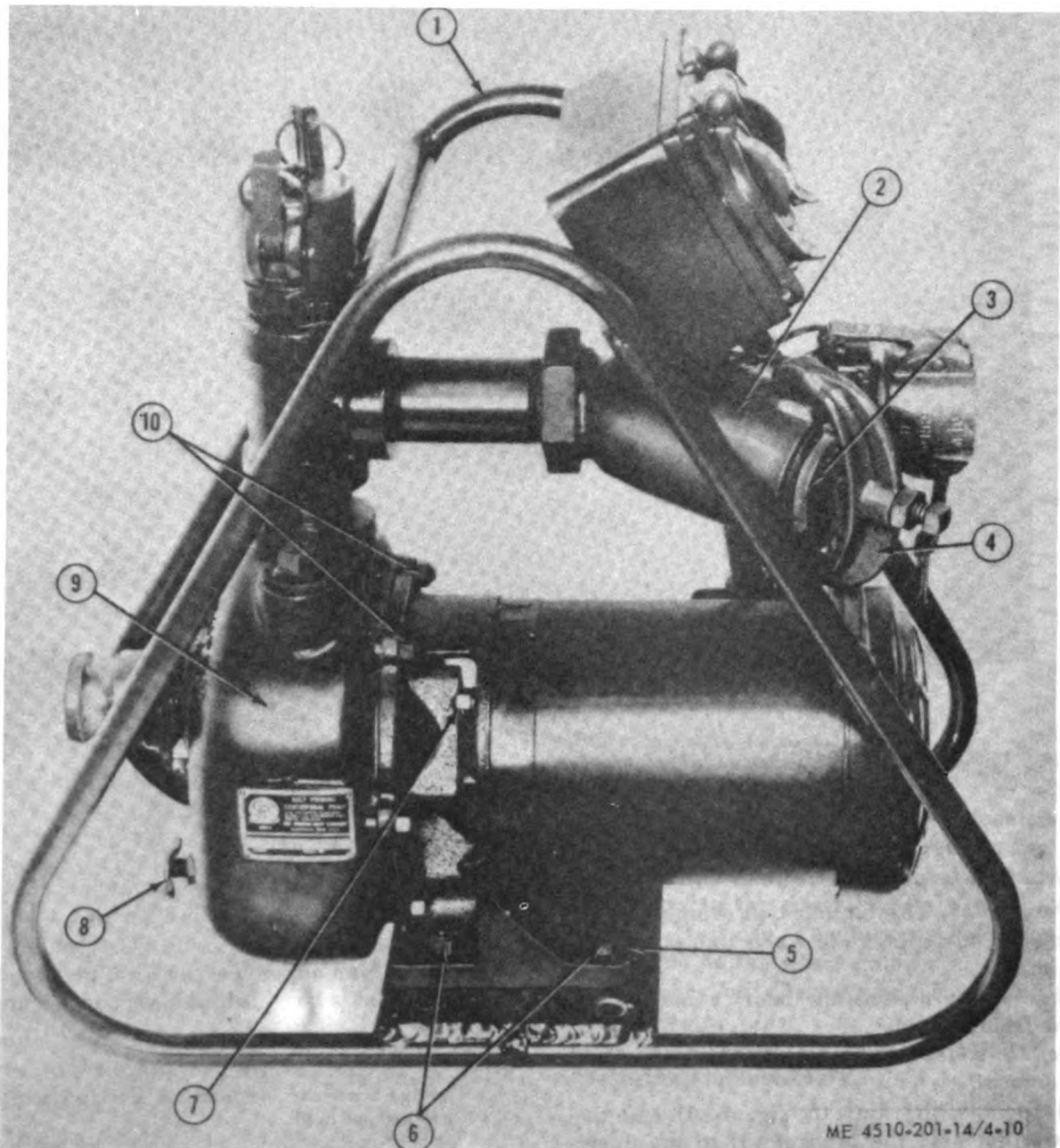
motor. The motor removal procedure would be the same (para 4-25).

(7) Remove the six screws that hold the cover to the control panel box (2) and remove the cover from the box.

(8) Remove the two nuts and the ground wire from the capscrews (1) that secure the control panel box to the frame.

(9) Remove the capscrews that hold the control panel box to the frame, and remove the box with the conduit tube from the frame.

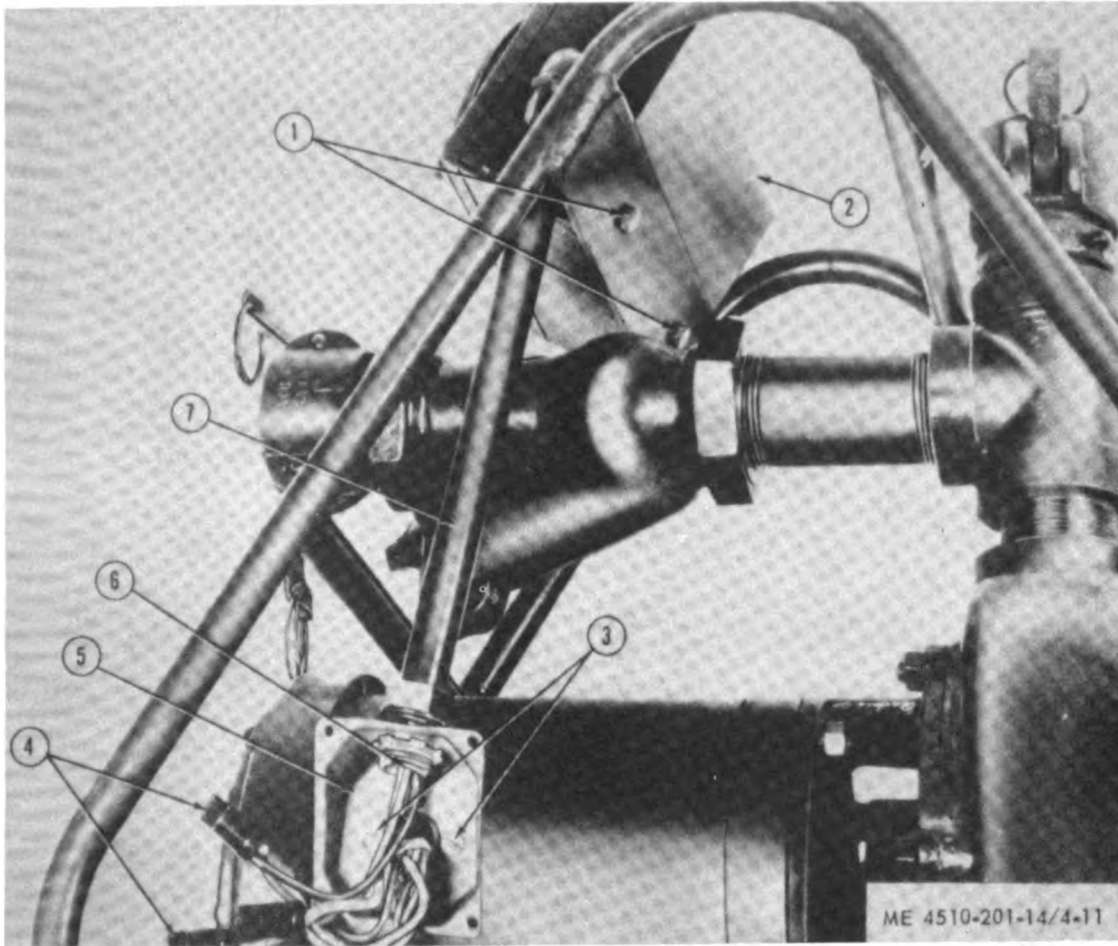
*e. Installation.* Replace defective frame with a serviceable one, and install it by reversing the procedure in *d* above.



*Figure 4-10. Water pump assembly, left-side view.*

**KEY TO figure 4-10:**

- 1 Frame, pump
- 2 Strainer, water line
- 3 Cap, water line strainer
- 4 Clamp, water line strainer cap
- 5 Bracket
- 6 Nuts, self-locking
- 7 Nut, motor mounting
- 8 Cock, drain
- 9 Housing, pump
- 10 Nuts, pump mounting



- 1 Capscrews
- 2 Box, control panel
- 3 Screws
- 4 Nuts, wire
- 5 Box, electrical connector
- 6 Nut, conduit
- 7 Tube, conduit

**Figure 4-11. Water pump electrical connections.**

#### 4-25. Water Pump Electric Motor

*a. Description.* The electric motor is mounted to the pump housing inside the frame of the water pump. It furnishes the power to operate the water pump.

##### NOTE

Electric motors furnished with some of the bath units and as replacements differ in that they have no box affixed to them for making the motor connections. These motors have a conduit elbow going into the side of the motor and connections are made through the access plate located on the motor. Motor removal procedures would be the same.

##### *b. Removal.*

(1) Remove the electric motor and the pump from the frame (paras 4-24 *d* (1) thru (6)).

(2) Remove the nuts (10, fig. 4-10) from the studs that attach the pump housing to the bracket (5).

(3) Separate the pump housing (2, fig. 4-12) from the bracket (3) as illustrated in figure 4-12, and remove the gasket (1) from the bracket (3, fig. 4-13).

(4) Remove the screws (1) that hold the vane

plate (2) to the bracket (3), and remove the vane plate from the bracket.

(5) Unscrew and remove the nut (4) from the motor shaft by inserting a screwdriver in the slot in the fan end of the motor to keep the shaft from turning as the nut is removed.

(6) Unscrew and remove the impeller (23, fig. 4-14) from the motor shaft.

(7) Remove the shims (6), washer (24), mechanical seal (5), stationary seals (4 and 25) from the motor shaft.

(8) Remove the nuts (7, fig. 4-10) from the studs that hold the motor to the bracket (5).

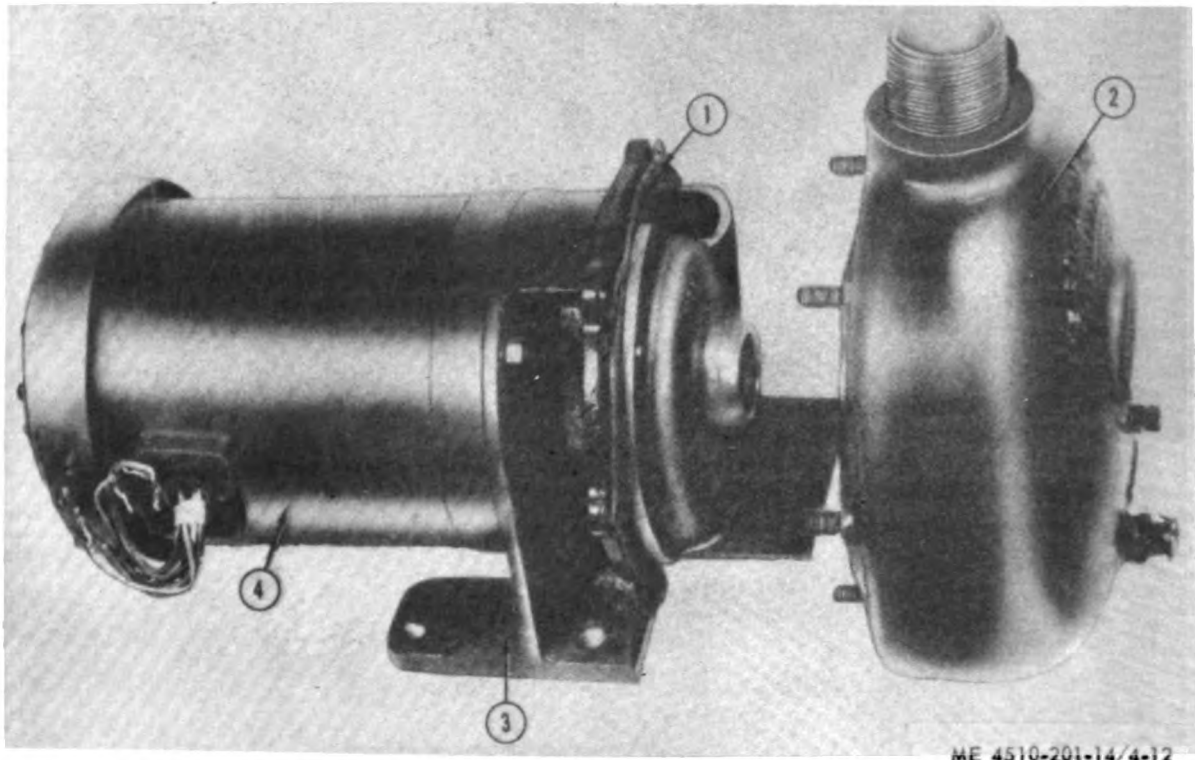
(9) Remove the motor from the bracket.

*c. Inspection.* Inspect for broken or cracked motor, damaged shaft threads, and bent shaft.

*d. Installation.* Replace defective motor with a serviceable one, and install it by reversing the procedure in *b* above. Refer to the wiring diagram in figure 4-15 for connecting the wires.

##### NOTE

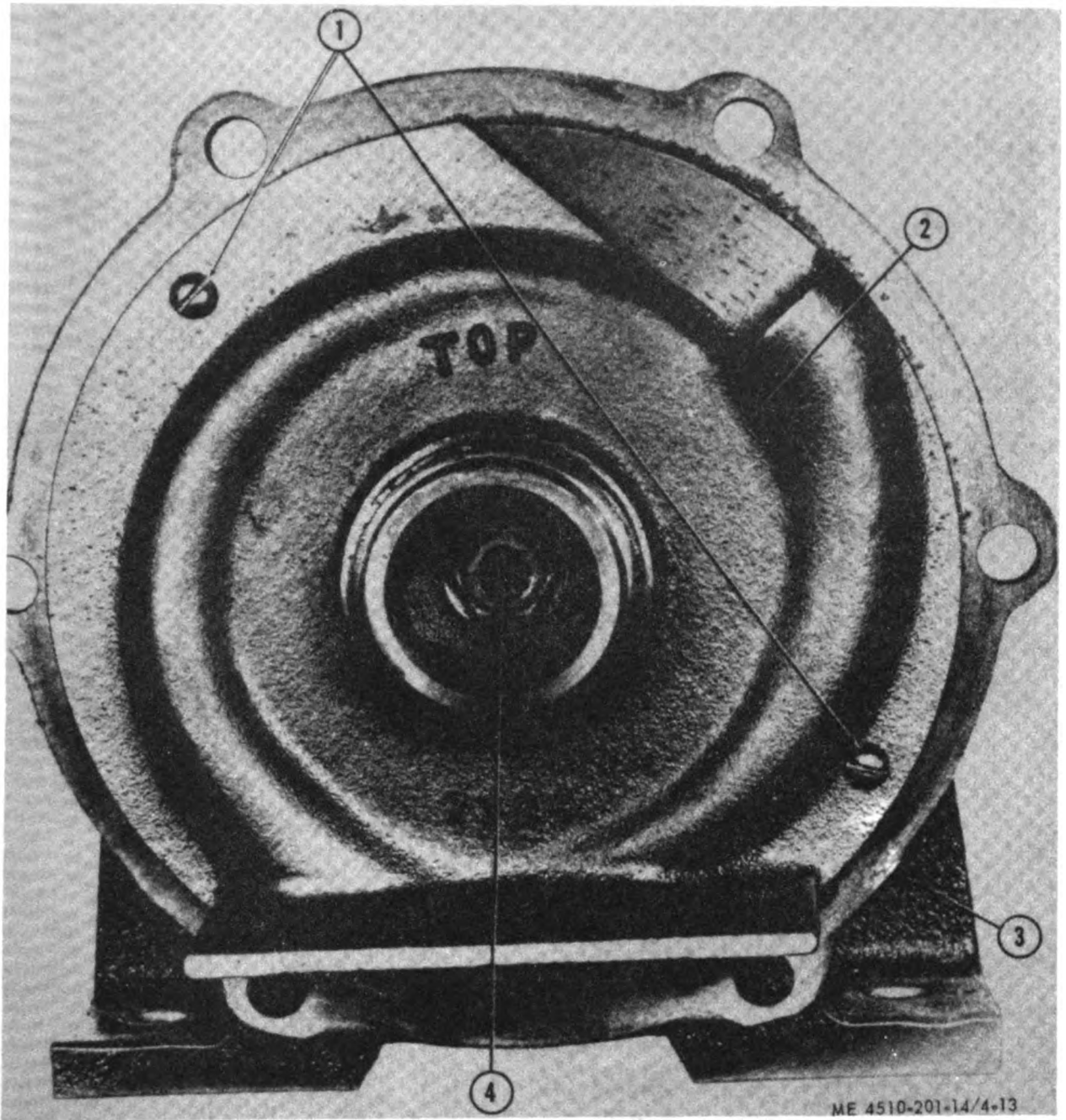
Be sure to check the rotation of the motor. It should turn or rotate in the direction in which the arrow points on the water pump housing. Reverse the rotation of the motor by interchanging any two of the external leads at the motor.



- 1 Gasket, pump housing
- 2 Housing, pump
- 3 Bracket, pump
- 4 Motor, pump

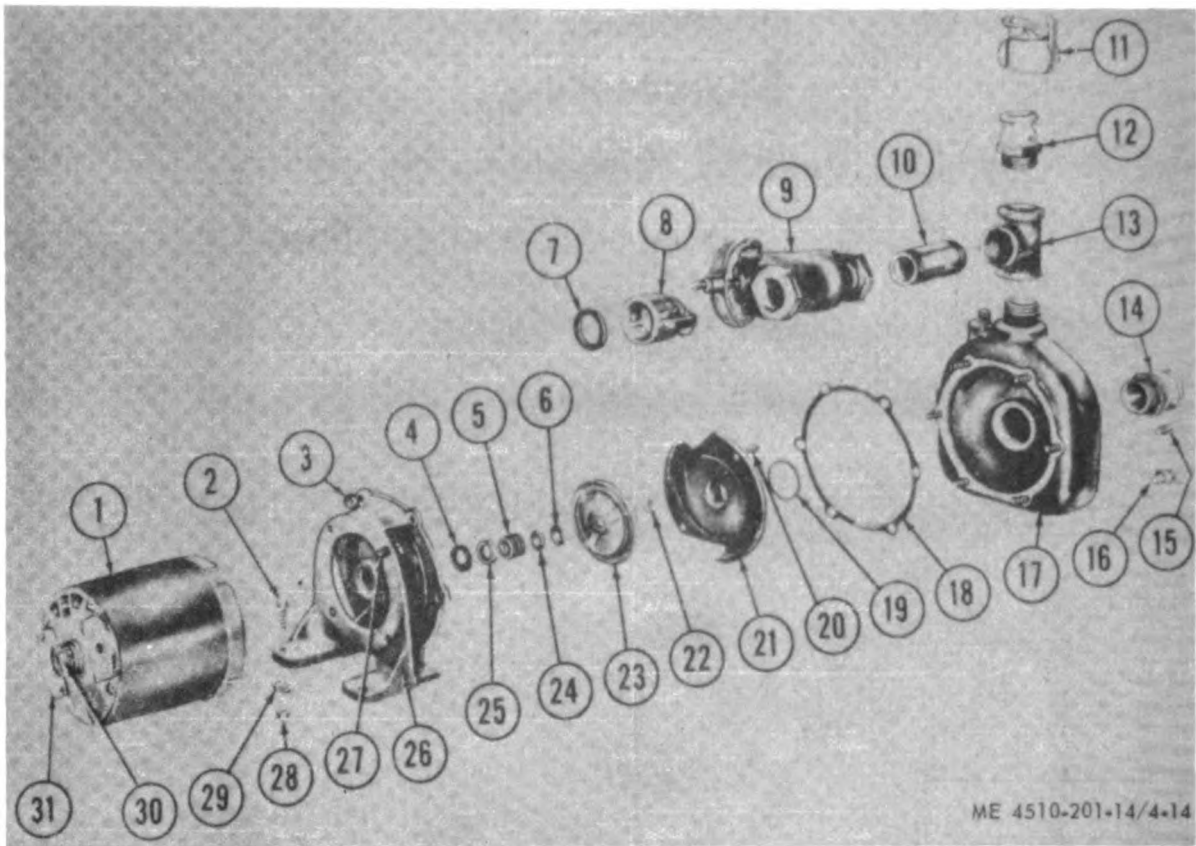
Figure 4-12. Pump housing removed from bracket and motor.





- 1 Screws
- 2 Plate, vane
- 3 Bracket, pump
- 4 Nut, impeller mounting

*Figure 4-13. Vane plate mounted on pump bracket.*



- |                            |                                       |
|----------------------------|---------------------------------------|
| 1 Motor, electric          | 17 Housing, pump                      |
| 2 Capscrew                 | 18 Gasket, pump housing               |
| 3 Nut                      | 19 O-ring rubber                      |
| 4 Seal, stationary         | 20 Screw, vane plate-to-base          |
| 5 Seal, mechanical         | 21 Plate, vane                        |
| 6 Shim, impeller adjusting | 22 Nut, impeller mounting             |
| 7 Gasket                   | 23 Impeller                           |
| 8 Coupler                  | 24 Washer, seal                       |
| 9 Strainer, water line     | 25 Seal, stationary                   |
| 10 Nipple, pipe            | 26 Bracket                            |
| 11 Cap, dust               | 27 Screw, motor-to-bracket            |
| 12 Coupling-half           | 28 Nut, self-locking                  |
| 13 Tee                     | 29 Lockwasher                         |
| 14 Coupling-half           | 30 Plug, motor end shield             |
| 15 Plug, drain             | 31 Plate, motor wiring cover (access) |
| 16 Cock, drain             |                                       |

*Figure 4-14. Water pump, disassembled.*

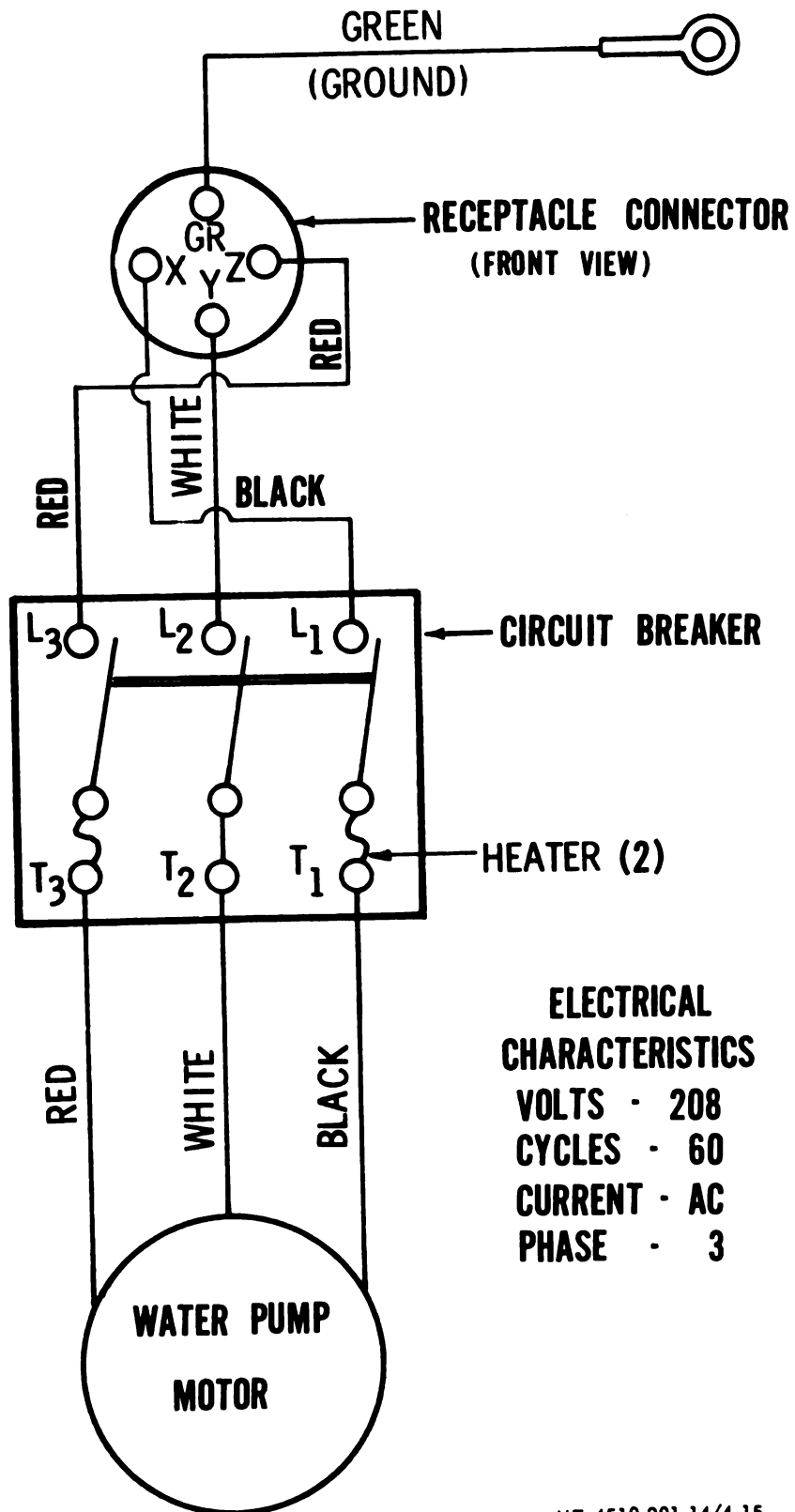


Figure 4-15. Wiring diagram for water pump.



#### 4-26. Water Pump

*a. Description.* The water pump is mounted inside the water pump frame, and is operated by an electric motor. It draws water through the suction strainer and the hose, from the water source, and forces it through the discharge hose to the water heater. On the pump housing a drain cock is located. It is used to drain the water from the pump.

##### *b. Removal.*

(1) Remove the electric motor and the pump from the pump frame (para 4-24 *d* (1) thru (6)).

(2) Remove the nuts from the studs that hold the pump housing (9, fig. 4-10) to the bracket (5).

(3) Separate the pump housing (2, fig. 4-12) from the bracket (3) as illustrated in figure 4-12, and remove the gasket from the bracket (3, fig. 4-13).

(4) Unscrew and remove the water line strainer (9, fig. 4-14), with the pipe nipple (10) and with tee (13) from the housing (17).

(5) Remove the vane plate (21, fig. 4-14) from the bracket (26), and remove the impeller (23) from the motor shaft (paras 4-25 *b* (2) thru (6)).

(6) Remove the shims (6), washer (24), mechanical seal (5), stationary seals (4 and 25) from the motor shaft.

(7) Unscrew and remove the drain cock (8, fig. 4-10) from the pump housing (9).

##### *c. Inspection.*

(1) Inspect the housing for breaks, cracks and damaged threads.

(2) Inspect for broken, cracked or dirty impeller and vane plate.

(3) Examine the mating surfaces of the seals to see that they are highly polished, and are not pitted, scratched and corroded.

(4) Inspect the drain cock for broken handle and damaged threads.

*d. Servicing.* Clean dirt and foreign matter from the impeller and the vane plate.

*e. Repair.* Replace a defective pump housing, vane plate or impeller. Repair the water pump by installing a new water pump repair kit.

*f. Adjustment.* Adjust the impeller by installing or removing the impeller adjusting shims (6, fig. 4-14). Install shims until the impeller will rub against the vane plane when it is installed. Remove 0.004 shim and install impeller and vane plate. The impeller should turn freely without rubbing against the vane plate after the proper adjustment has been made.

*g. Installation.* Install the water pump drain cock by reversing the procedures in *b* above.

#### 4-27. Control Assembly

##### *a. Control Panel Circuit Breaker Subassembly.*

(1) *Description.* A circuit breaker subassembly is a switch device which stops the flow of current in a continuous circuit when the circuit is overloaded. The instructions in this paragraph pertain to the circuit breaker subassembly either on the water heater or the water pump.

##### (2) *Removal.*

(a) Remove the six screws (fig. 4-11) that secure the control panel box cover to the box, and separate the cover from the box.

(b) Remove the screws that secure the circuit breaker subassembly to the cover, and separate the subassembly from the cover.

(c) Turn the circuit breaker subassembly over to expose the wire connections as shown in figure 4-16.

(d) Loosen the screws that attach the wire connections to the circuit breaker subassembly.

(e) Remove the wires from the circuit breaker subassembly.

##### NOTE

Tag the wires for identification if color-coded wires are not used.

(3) *Inspection.* Use an ohmmeter to check for continuity across the terminals with the switch in the ON position. Inspect for damaged threads and broken case.

(4) *Installation.* Replace defective circuit breaker subassembly with a serviceable one and install it by reversing the procedure in *a* (2) above. Connect the wires according to the wiring diagram in figure 4-15 for the water pump.

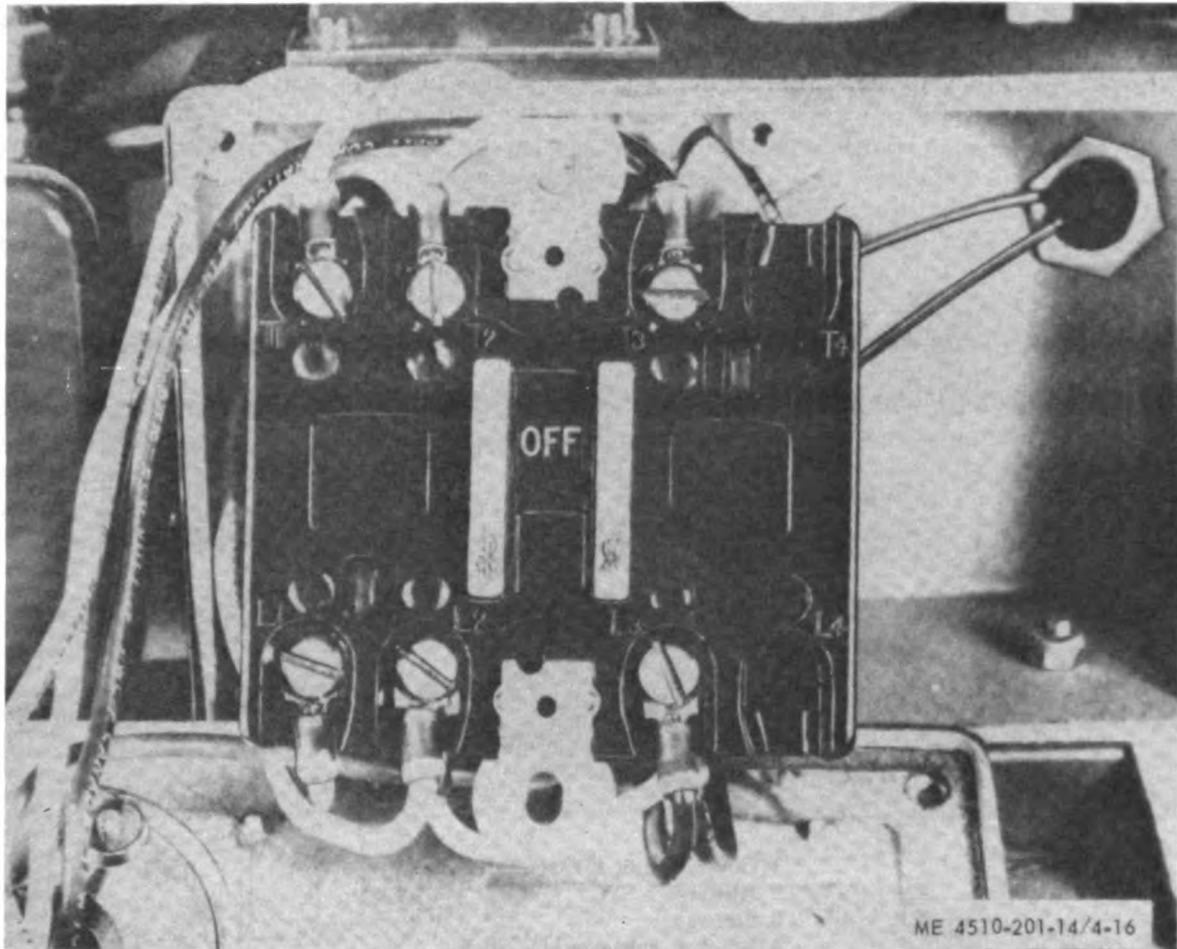


Figure 4-16. Circuit breaker subassembly showing wire connections.

**b. Circuit Breaker Subassembly Overload Heaters.**

(1) *Description.* There are two overload heaters in each circuit breaker subassembly; they act as a connecting link which carries the current of the circuit and which breaks the circuit when the circuit is overloaded. The instructions in this paragraph pertain to the circuit breaker subassembly overload heaters either on the water heater or the water pump.

(2) *Removal.*

(a) Remove the six screws that secure the box cover to the control panel box, and pull the cover from the box.

(b) Remove the cover (1, fig. 4-17) from the circuit breaker subassembly (4).

(c) Remove the screws (3 and 5) that secure the heaters (2) to the circuit breaker subassembly, and remove the heaters.

(3) *Inspection.* Inspect for broken or burned heaters.

(4) *Installation.* Replace defective heater with a serviceable one, and install it by reversing the procedure in b (2) above.

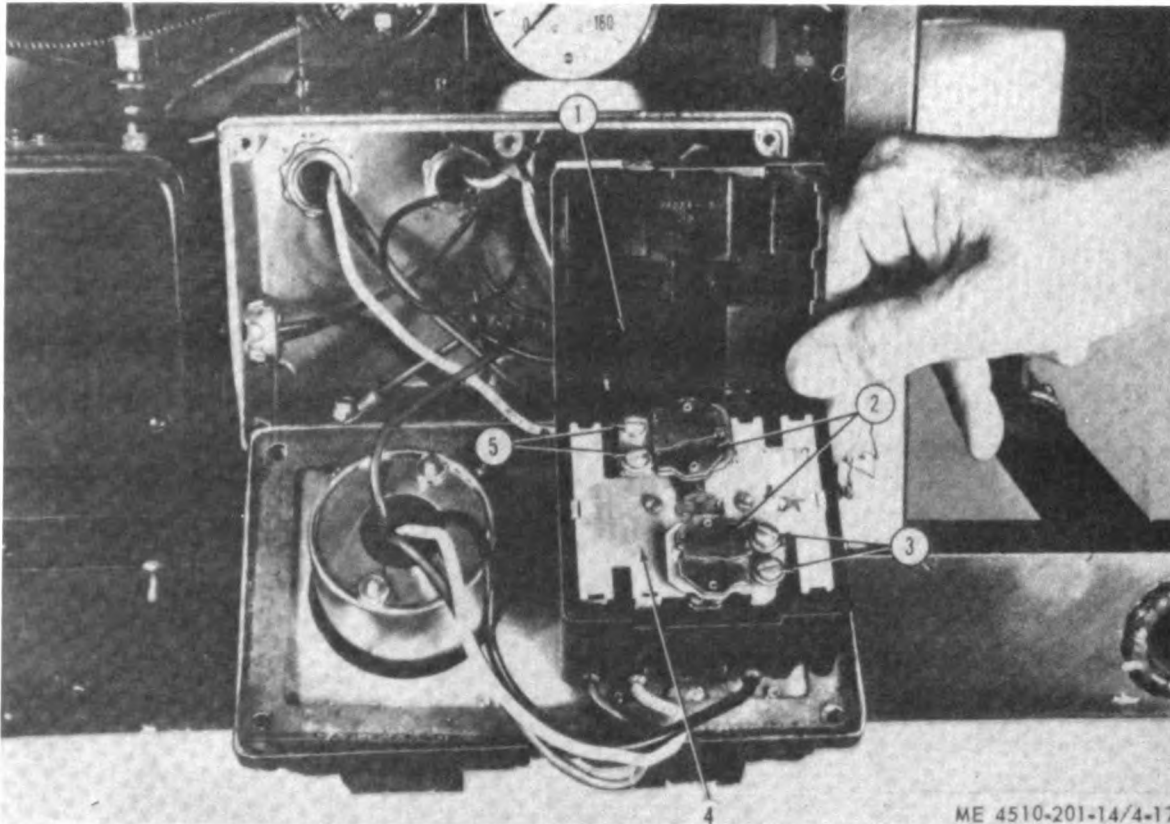
**c. Water Pump Control Panel Box.**

(1) *Removal.*

(a) Remove the circuit breaker subassembly, a (2) above.

(b) Remove the control box receptacle connector as follows:

1. Remove the four screws that attach the connector with cover, to the control panel box cover.



- 1 Cover, circuit breaker subassembly
- 2 Heaters
- 3 Screws
- 4 Breaker, subassembly, circuit
- 5 Screws

Figure 4-17. Circuit breaker subassembly cover opened to show overload heaters.

2. Raise the hinged cover, and remove the insulator from the connector.

3. Loosen the four screws that hold the wires to the connector, and remove the wires from the connector, thus freeing the connector with gasket and hinged cover.

**NOTE**

Tag the wires for identification if color-coded wires are not used.

(c) Remove the conduit nut from the conduit elbow located on the end of the panel box.

(d) Slide the elbow from the panel box.

(e) Remove two nuts and the ground wire from the capscrews that secure the panel box to the water pump frame, and remove the capscrews that secure the panel box to the frame.

(f) Remove the panel box from the frame, sliding it over the ends of the wire.

(2) *Inspection.* Inspect for broken panel box and damaged threads. Check for improper closure of the cover.

(3) *Installation.* Replace defective box with a serviceable one, and install it by reversing the procedure in c (1) above. Connect the wires according to the wiring diagram in figure 4-15.

**NOTE**

Make sure the green ground wire is properly connected before the panel box cover is installed.

**d. Conduit, Electrical Fittings, and Wiring.**

**(1) Removal.**

(a) Remove the two screws that attach the cover to the electrical connector box (5, fig. 4-11).

(b) Remove the wire nuts (4) from the wire connections, and disconnect the wires running from the control panel box (2) to the electrical connector box.

**NOTE**

Tag the wires for identification if color-coded wires are not used.

(c) Remove the connector nuts from the connector that holds the conduit tube (7) to the electrical connector box.

(d) Remove the six screws that hold the cover to the control panel box, and remove the cover.

(e) Disconnect the wires from the circuit breaker assembly.

(f) Remove the nut that holds the conduit elbow to the control panel box.

(g) Remove the conduit tube with elbow from the control panel box.

(h) Separate the conduit tube from the elbow.

(i) Pull the wires from the conduit tube.

(2) **Inspection.** Inspect for bent and broken conduit tube, and check the tube and the electrical fittings for damaged threads. Inspect for broken wires and frayed insulation.

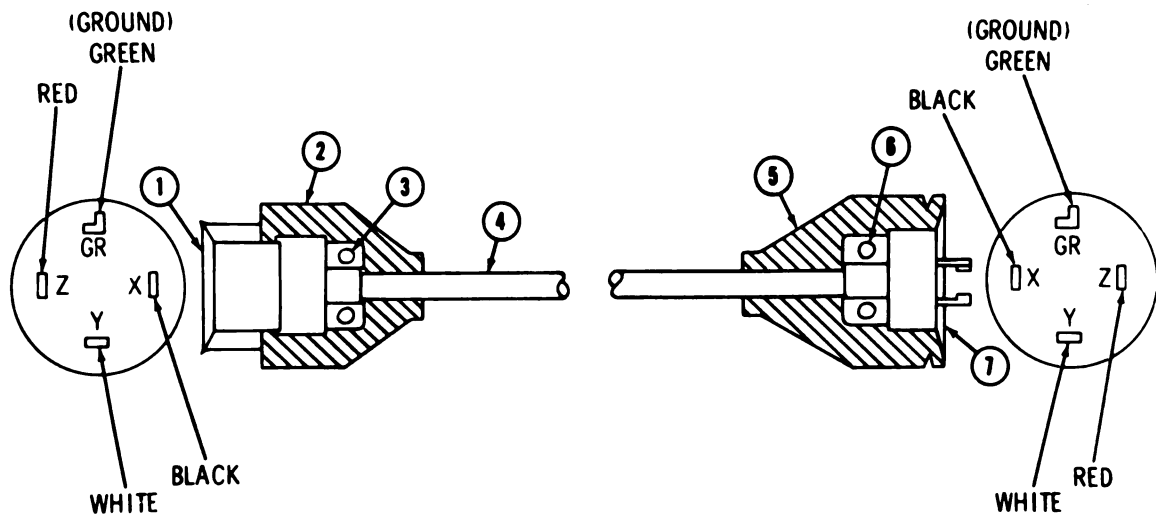
(3) **Repair and Installation.** Tape bare wires

and replace defective items with serviceable ones. Reverse the procedure in d (1) above, tightening all electrical fittings securely. Refer to the wiring diagram in figure 4-15 for connecting the wires.

e. **Power Cord Cable, Plug Connectors, and Shields.** There are two power cord cables. One is used to connect the generator to the water heater, and the other one is used to connect the generator to the water pump. Each cable has a male plug connector on one end and a female plug connector on the other end. A rubber shield is used to protect each connector.

f. **Inspection.** Inspect for broken cables, frayed insulation, loose electrical connections, and broken or missing connectors and shields.

g. **Removal.** Remove the connectors (1 and 7, fig. 4-18) and the shields (2 and 5) from the power cord cable (4) as follows:



ME 4510-201-14/4-18

- 1 Connector, plug
- 2 Shield
- 3 Screw
- 4 Cable, power cord
- 5 Shield
- 6 Screw
- 7 Connector, plug

Figure 4-18. Wiring diagram of power cord cable.

## Section VIII. MAINTENANCE OF WATER HEATER ASSEMBLY

### 4-28. General

This section describes the organizational maintenance instructions for the items or components of the water heater listed as Group 03. Unless otherwise specified, the following instructions in this section apply generally to the water heater items or components used for all five Army models SPE 35, SPE 35A, SPE 41, SPE 44, SPE 45 and

York-Shipley Model YS49279. If different instruction is necessary for a particular model, it will be so indicated in the applicable paragraphs for the particular Army model number. Any deficiencies which the organizational maintenance personnel are not authorized to correct must be reported as stipulated in TM 38-750.

#### 4-29. Fuel Hose and Barrel Plug

a. *Description.* The barrel plug is used in the 55-gallon fuel drum, and the fuel hoses are connected to the barrel plug. The barrel plug has a fuel supply pipe that extends to the bottom of the fuel drum and a short fuel return pipe (fig. 4-19).

b. *Removal.*

(1) Disconnect the fuel feed and return hose assemblies (4, fig. 4-20) from the barrel plug (2).

(2) Unscrew and remove the barrel plug from the fuel drum.

(3) Remove the two adapters (1) from the barrel plug.

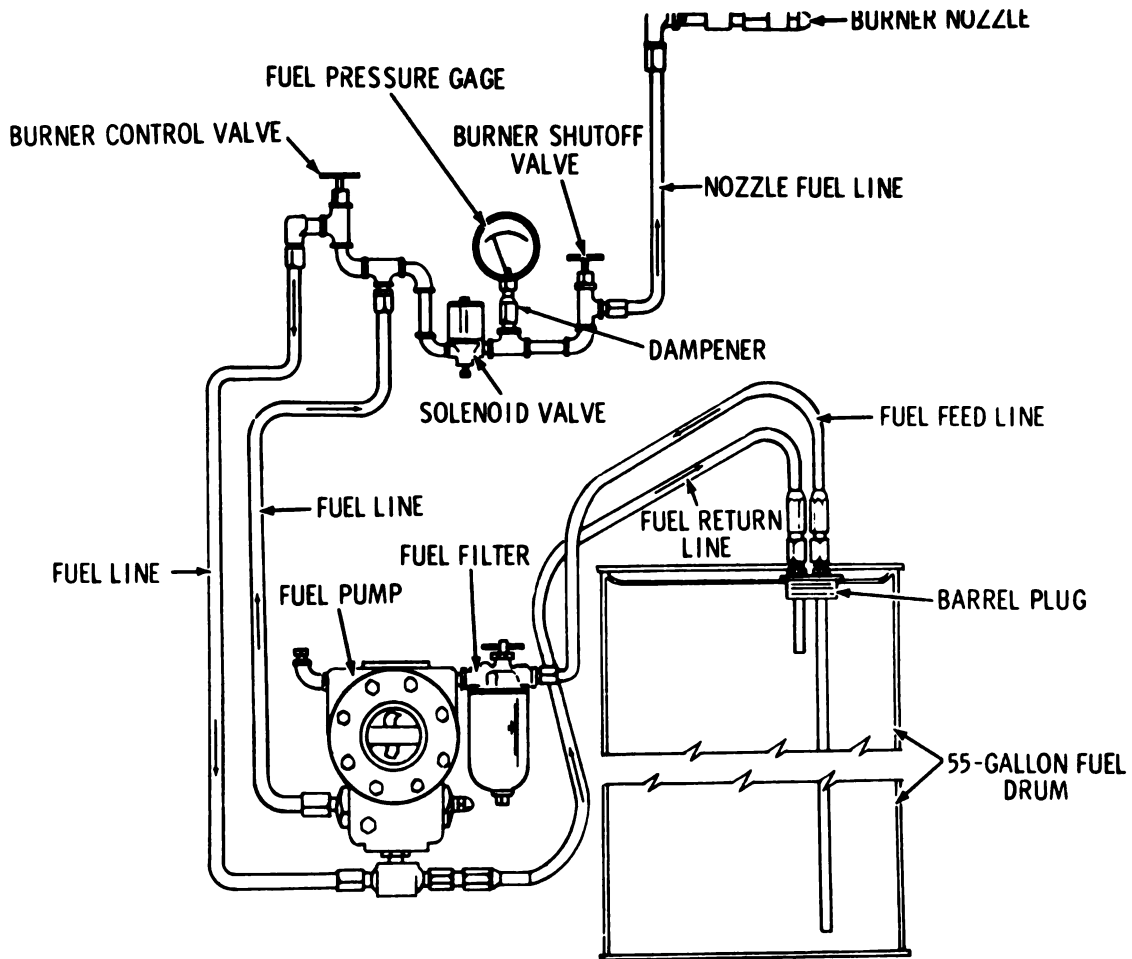
(4) Unscrew and remove the supply and return pipes (3 and 5) from the barrel plug.

(5) Unscrew and remove the fuel hose assemblies (4, fig. 4-20) from the connections on the fuel pump and on the fuel filter.

(6) Unscrew and remove the fuel hose assemblies from the adapters (1) on the barrel plug (2).

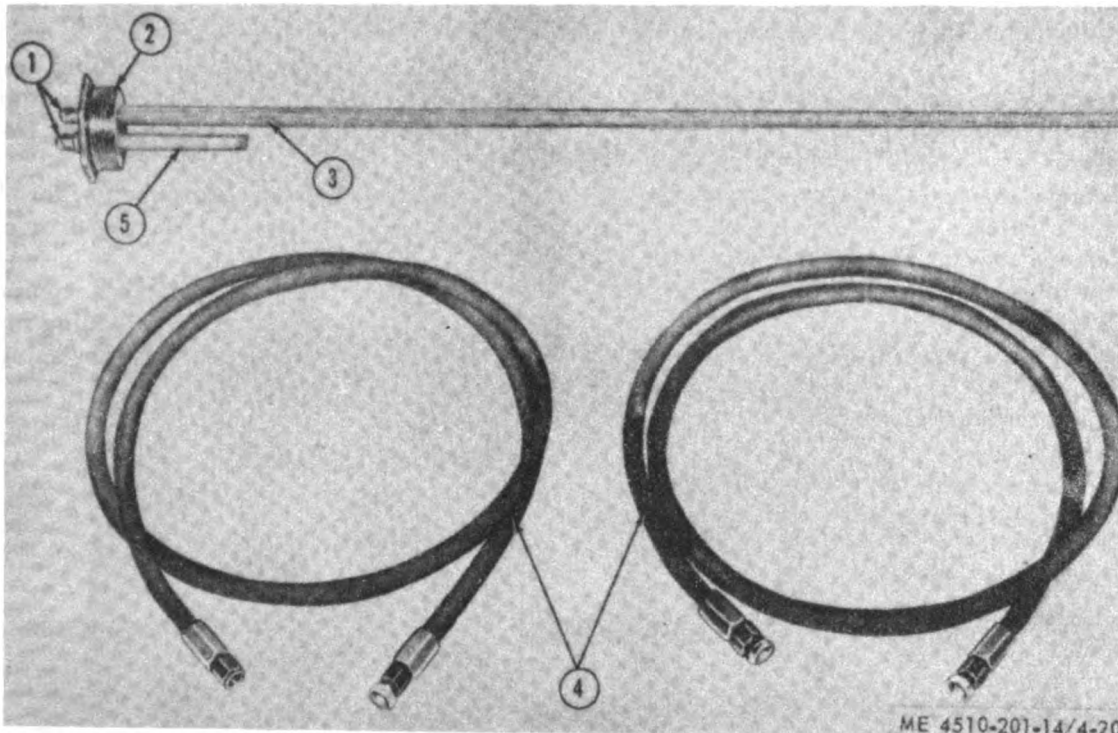
c. *Inspection.* Inspect for broken or cracked plugs, adapters, pipes and for damaged threads. Inspect the hose assemblies for crossed or damaged threads, and for frayed and excessively worn places on the hoses.

d. *Installation.* Replace defective parts and hose assemblies with serviceable ones, and install them by reversing the procedure in b above.



ME 4510-201-14/4-19

Figure 4-19. Schematic drawing of burner fuel system.



- 1 Adapters
- 2 Plug, barrel
- 3 Pipe, fuel supply
- 4 Hose assemblies, fuel feed and return
- 5 Pipe, fuel return

Figure 4-20. Barrel plug and fuel hose assemblies

#### 4-30. Ignition Transformer

*a. Description.* The transformer is mounted on the lower right end of the water heater. It produces a constant high voltage at the burner electrodes. There are two transformer-to-burner electrode ignition cable assemblies. These two cables carry the current from the transformer to the electrodes. Each cable assembly is made up of a high tension lead wire running through a radio-shielded housing.

##### *b. Removal.*

(1) *Transformer, Adapters, Conduit Outlet and Cover.*

(a) Loosen the two screws that secure the conduit outlet cover to the conduit outlet, and remove the cover.

(b) Remove the wire nuts and separate the wires.

(c) Loosen the conduit tube nut, and remove the tube (1, fig. 4-21) with wires from the conduit outlet.

(d) Unscrew and remove the two cable assemblies (2) from the transformer adapters.

(e) Remove the nuts, lockwashers, and capscrews that hold the transformer to the bracket.

(f) Remove the transformer from the bracket.

(g) Unscrew and remove the two adapters from the transformer.

(h) Loosen the conduit locknut, and unscrew and remove the conduit outlet from the transformer.

(i) Unscrew the locknut from the transformer.

##### (2) *Mounting Bracket.*

(a) Remove the nuts, lockwashers, and capscrews that secure the transformer to the bracket.

(b) Remove the nuts, lockwashers, and capscrews that hold the bracket to the water heater.

(c) Remove the two tapping screws that hold the bracket to the skid.

(d) Support the transformer, and remove the bracket from the skid.

##### (3) *Conduit Tube and Wires.*

(a) Loosen the screws on the conduit outlet cover, and remove the cover from the conduit outlet.

(b) Remove the wire nuts and disconnect the wires in the conduit outlet.

##### NOTE

Tag the wires for identification if color-coded wires are not used.

(c) Loosen the conduit tube nut, and remove the tube (1) with wires from the conduit outlet.

(d) Remove the six screws that hold the cover (5, fig. 4-22) to the control panel box (4), and remove the cover.

(e) Remove the two transformer wire nuts, and separate the wires.

(f) Remove the nut that holds the conduit tube to the control panel box, and remove the tube with the two wires.

(g) Remove the two wires from the conduit tube.

**(4) Transformer-to-Burner Electrode Ignition Cable Assembly.**

(a) Unscrew and remove the cable assemblies (2, fig. 4-21) from the adapters on the transformer.

(b) Unscrew and remove the cable assemblies from the electrodes.

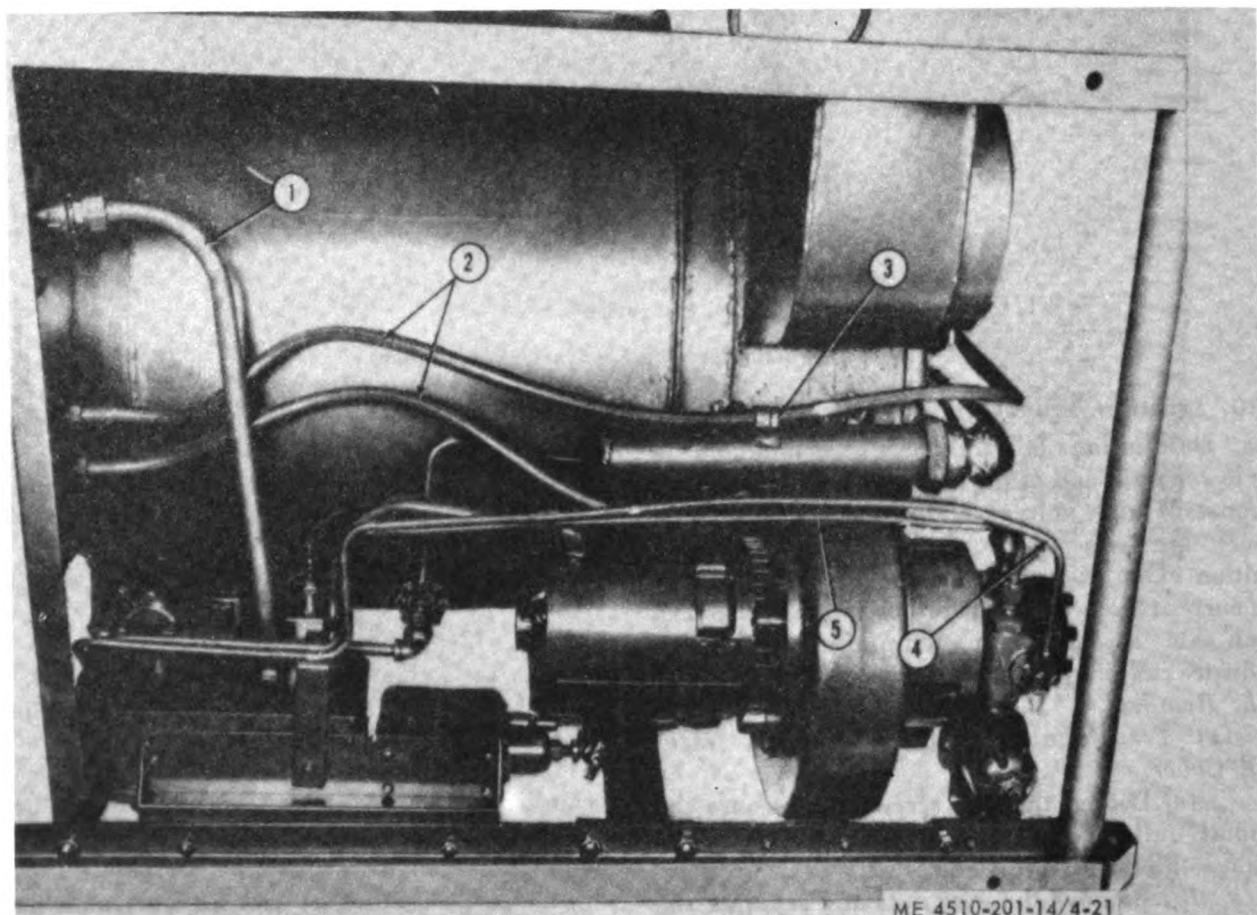
(c) Remove the cable assemblies from the straps (3), located on the lower heater manifold.

(d) Remove the cable assemblies from the heater.

c. *Inspection.* Inspect components for bends, cracks or breaks. Inspect for damaged or crossed threads.

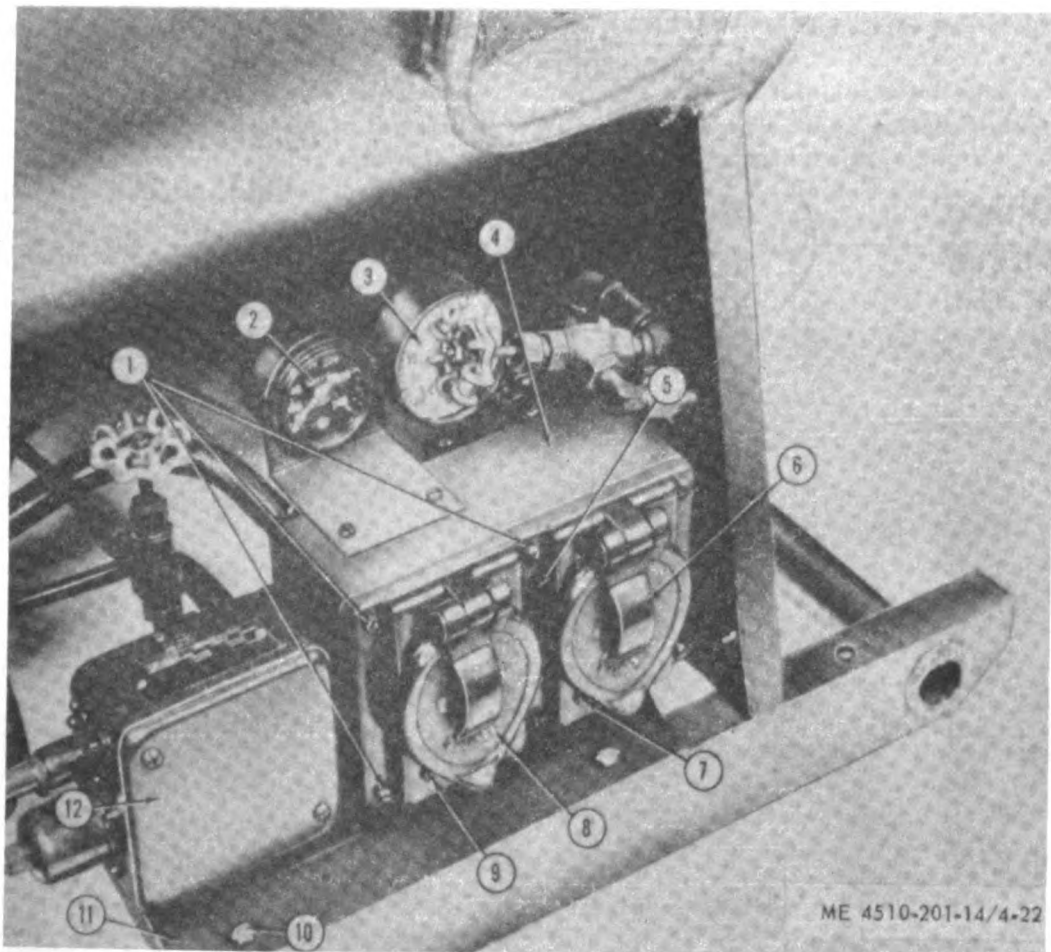
d. *Installation.* Replace defective components as necessary. Connect all wires according to figure 4-23. Install components by reversing the procedure in b above.

e. *Testing.* To test the transformer, refer to information in paragraph 6-7.



- 1 Tube, transformer conduit
- 2 Cable assemblies, transformer-to-burner electrode
- 3 Strap, retaining
- 4 Line assembly, fuel
- 5 Line assembly, fuel

*Figure 4-21. Water heater, bottom view.*



- 1 Screws
- 2 Gage, water temperature
- 3 Gage, fuel pressure
- 4 Box, control panel
- 5 Cover, control panel box
- 6 Cover, switch
- 7 Screw
- 8 Cover, receptacle connector hinged
- 9 Screw
- 10 Capscrew
- 11 Bracket, control panel box
- 12 Control, pressure and temperature

*Figure 4-22. Water heater control panel box and gages.*



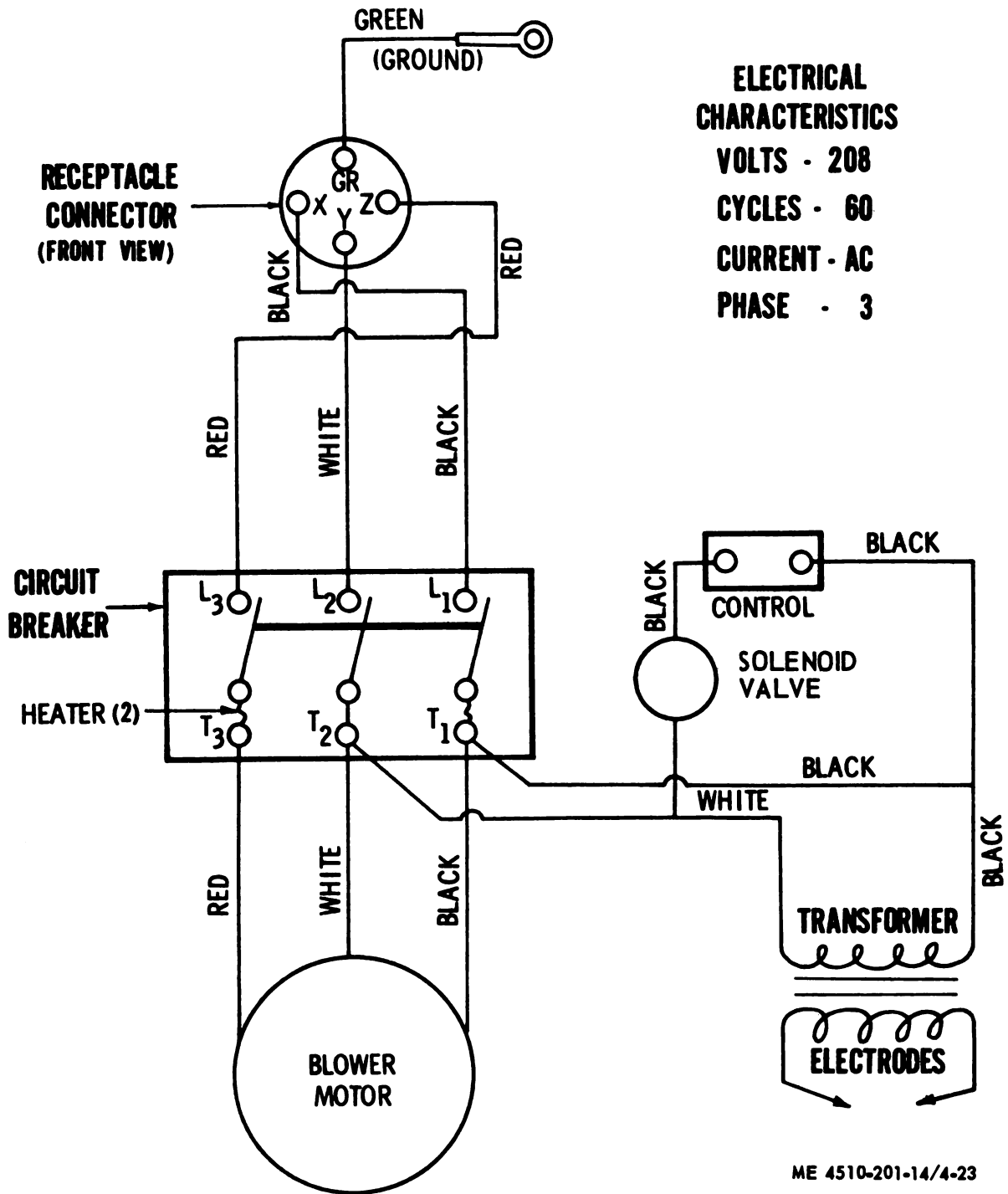


Figure 4-23. Wiring diagram for water heater.

#### 4-31. Skid and Skid Level

*a. Description.* The skid acts as a base to support the water heater during operation and transit. On Army models SPE 35 and SPE 35A only, there is a bubble-type level, mounted on the skid beneath the blower. It is used to level the water heater, longitudinally, when it is being set up for operation.

*b. Inspection.* Inspect for broken, cracked and bent skid (4, fig. 4-24). If a skid is bent, the heater

will not stay level during operation. A bent skid may also cause damage to the other components of the water heater. Inspect the level (2) for loose mounting, for broken cover and glass, and for free-bubble movement.

*c. Removal.*

(1) *Skid level.* Remove the nuts and screws (1 and 3) that hold the level to the skid (4), and remove the level.

## (2) Skid.

(a) Remove the two nuts and capscrews that hold the fuel filter bracket to the skid.

(b) Remove the two nuts and capscrews that hold the control panel box bracket to the skid.

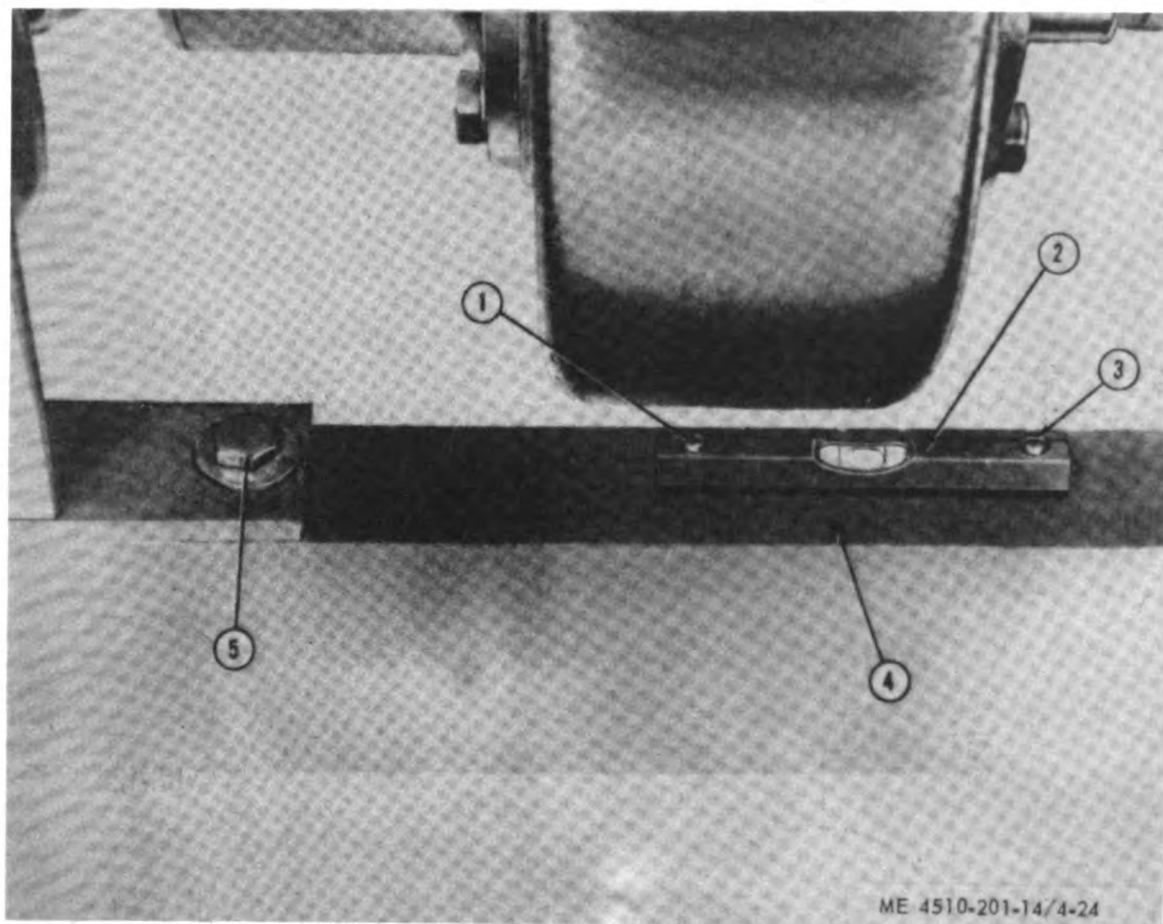
(c) Remove the two self-tapping screws that hold the transformer mounting bracket to the skid.

(d) Turn the water heater over on one side, and support it so the skid will be free.

(e) Remove the six nuts, lockwashers, and capscrews that hold the water heater to the skid, and remove the skid.

d. *Installation.* Replace a defective level or skid with a serviceable one. Install these items by reversing the procedure in c above.

e. *Repairing the Skid.* To repair the skid, refer to information in paragraph 6-9.



- 1 Screw
- 2 Level
- 3 Screw
- 4 Skid
- 5 Capcrew

Figure 4-24. Water heater skid and skid level.

## 4-32. Boiler Cover

### a. Removal.

(1) Disconnect the fuel line at the point where the line connects to the burner elbow.

(2) Disconnect the ignition cable assemblies at the points where the leads connect to the burner electrodes.

(3) Remove the self-locking cover nuts and the flat washers that secure the smokebox cover (1, fig. 4-25) to the gasket (2) and to the heater.

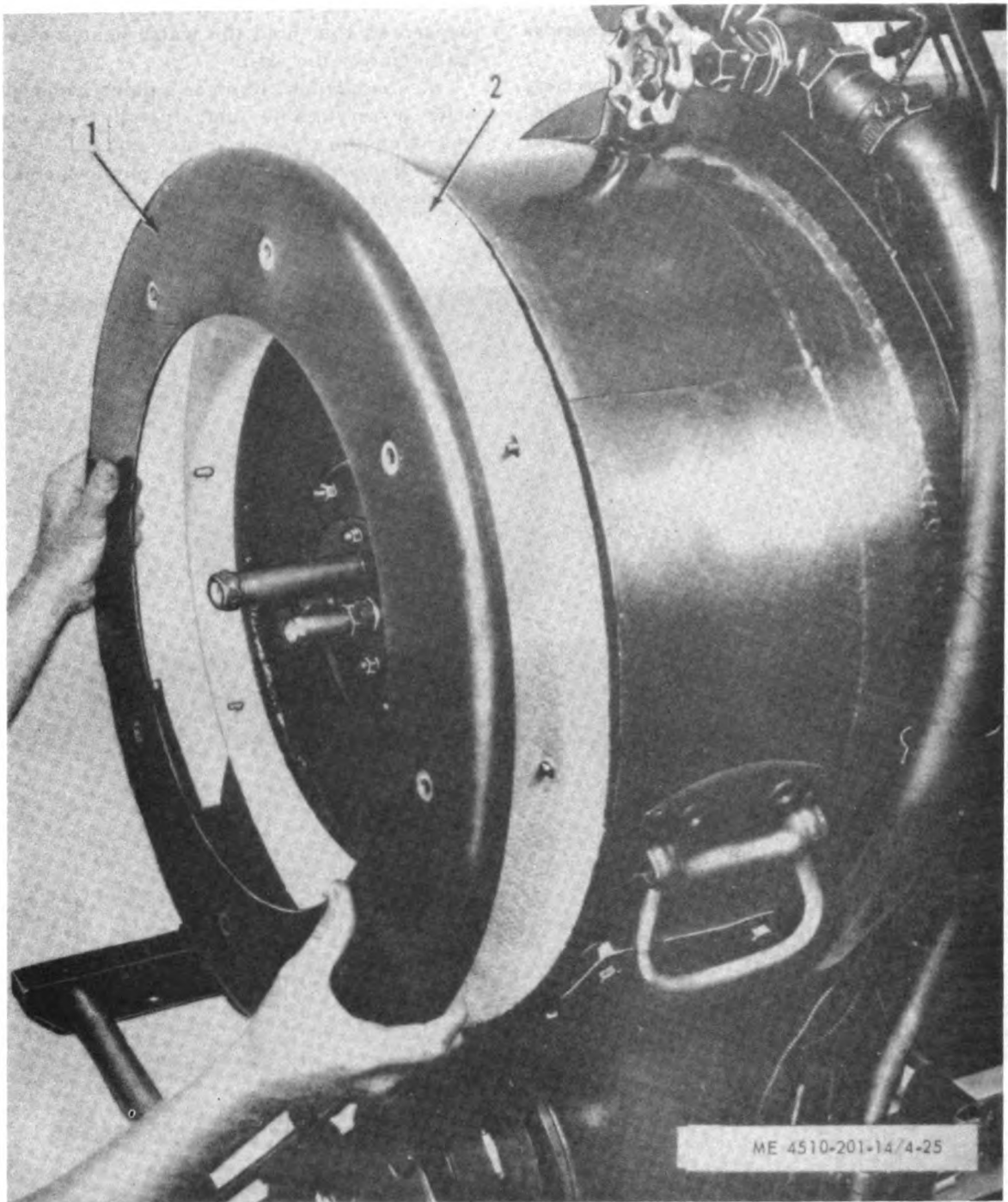
(4) Remove the cover and the gasket from the heater as shown in figure 4-25.

b. *Inspection.* Inspect for cracked, broken, and distorted cover. Inspect for deteriorated, broken, and torn gasket.

c. *Installation.* Replace defective cover and gasket with serviceable ones, and install them by reversing the procedure in a above. Make certain the gasket is seated properly.

### NOTE

Do not overtighten the cover nuts. To do so may distort the cover and cause leakage of smoke around the cover gasket.



- 1 Cover
- 2 Gasket

**Figure 4-25. Boiler box cover and gasket, removal and installation.**

## 4-33. Burner Assembly

### a. Description.

(1) *Burner sight hole cap assembly.* The burner sight hole cap assembly is located on the left end of the water heater. It is used to check the flame in the heater combustion chamber.

(2) *Electrode sight tube glass, gasket and bushing.* The electrode sight tube glass is mounted on the burner nozzle and electrode holder. It is used to check the electrode sparks.

(3) *Drain cock (combustion chamber).* This drain cock is located on the left end of the water heater tank. It is used to drain the condensation from the combustion chamber.

(4) *Burner electrodes, holder and gaskets.* The two burner electrodes are mounted in the holder on the burner head. They are terminals between which the electric current passes creating a spark to ignite the fuel in the combustion chamber.

(5) *Burner fuel nozzle, adapter and nipple.* The burner fuel nozzle, mounted on the inner side of the nozzle and electrode holder, sprays the fuel into the combustion chamber.

(6) *Burner head, gasket and air nose.* The burner head and air nose serve as a flame diffuser and air shield.

### b. Removal.

(1) *Burner sight hole cap assembly.* Unscrew and remove the assembly (7, fig. 4-26) from the sight tube on the water heater.

(2) *Electrode sight tube glass, gasket and bushing.*

(a) Unscrew and remove the bushing with the glass (6, fig. 4-26) and the gasket from the sight tube nipple (2). Separate the bushing, the glass, and the gasket.

(b) Unscrew and remove the nipple (2) from the nozzle and the electrode holder.

(3) *Drain cock (combustion chamber).* Unscrew and remove the drain cock from the water heater.

(4) *Burner electrodes, holder and gasket.*

(a) Unscrew and remove the cable assemblies (9 and 11, fig. 4-26) from the electrodes (8 and 12).

(b) Unscrew and remove the fuel feed line assembly (10) from the elbow.

(c) Remove the three nuts (3) and lockwashers that secure the holder (5) to the burner assembly (4).

(d) Remove the holder with the electrodes from the burner assembly as shown in figure 4-27.

(e) Bend the electrode wires so they will not strike the nozzle when the electrodes are removed.

(f) Unscrew and remove the electrodes (8 and 12, fig. 4-26) with the gaskets from the holder. Separate the gaskets from the electrodes.

(g) Unscrew and remove the nozzle with the adapter from the fuel nozzle adapter nipple.

(h) Loosen the two setscrews that secure the adapter nipple to the holder, and remove the adapter nipple.

(i) Remove the sight tube nipple (2) from the holder.

(5) *Burner fuel nozzle, adapter and nipple.*

(a) Remove the burner nozzle and electrode holder from the burner assembly (para b(4) (a) thru (d)).

(b) Remove the adapter with nozzle from the fuel nozzle adapter nipple.

(c) Remove the nozzle (1, fig. 4-28) with screen (2) from the adapter (3).

(d) Unscrew and remove the screen (2) from the nozzle.

(e) Remove the nipple from the holder.

(6) *Burner head, gasket and air nose.*

(a) Remove the burner nozzle and electrode holder (para b(4) and b(5)) above.

(b) Remove the four nuts (1, fig. 4-26) and lockwashers that secure the burner head to the water heater.

(c) Remove the burner head (1, fig. 4-29) and the gasket (2) from the heater.

(d) Remove the two screws that secure the air nose (3) to the burner head, and separate the air nose from the burner head.

### c. Inspection.

(1) *Burner sight hole cap assembly.* Inspect the cap assembly for broken or cracked glass and for stripped or damaged threads.

(2) *Electrode sight tube glass, gasket and bushing.* Inspect for broken or cracked glass and leaking gasket. Check the bushing for damaged threads.

(3) *Drain cock (combustion chamber).* Inspect the drain cock for proper seating in closed position, for damaged or stripped threads, for broken handle, and for clogged openings.

(4) *Burner electrodes, holder and gaskets.* Inspect for broken, cracked, and distorted holder and nipples and for damaged threads. Inspect the electrodes for burned spots, and inspect the insulator for cracks, breaks and lines (etchings). Check for broken or distorted gaskets.

(5) *Burner fuel nozzle, adapter and nipple.* Inspect for clogged, cracked, and excessively worn nozzle. Inspect the nozzle for carbon deposits, the nozzle screen for broken mesh and dirty or clogged passages, and the adapter for damaged threads.

(6) *Burner head, gasket and air nose.* Inspect for dirty, broken, cracked, and bent burner head and air nose. Check for carbon deposits on the burner head and the air nose.

**d. Servicing.**

(1) *Burner electrodes.* Wash the electrodes in soapy water, and dry them thoroughly.

(2) *Burner fuel nozzle, adapter and nipple.* Wash the nozzle, adapter and screen in paint thinner and scrub the nozzle with a small brush. Dry the nozzle and screen thoroughly. Be extremely careful when cleaning the nozzle to avoid damaging the orifice or the tip. Do not force a wire or any metallic object through the nozzle orifice.

(3) *Burner head and air nose.* Clean all carbon and dirt from the burner head and the air nose.

(4) *Electrode sight tube glass.* Wash the glass in soapy water, and dry it thoroughly.

**e. Adjustment of Burner Electrodes.** Adjust the burner electrodes as follows:

**NOTE**

The electrodes must be installed in the holder before making the adjustment.

(1) Bend the electrodes until the spark gap is five thirty-seconds of an inch, and the electrodes are located one-eighth of an inch outward and one-half of an inch upward from the hole in the burner nozzle as shown in figure 4-30.

(2) Install the nozzle and the electrode holder in the burner. Tighten the nuts firmly.

**f. Repair of the Burner Head.** Repair the burner head by replacing defective items with serviceable ones.

**g. Installation.**

(1) *Burner sight hole cap assembly.* Replace defective cap assembly with a serviceable one, and install it by reversing the procedure in *b* (1) above.

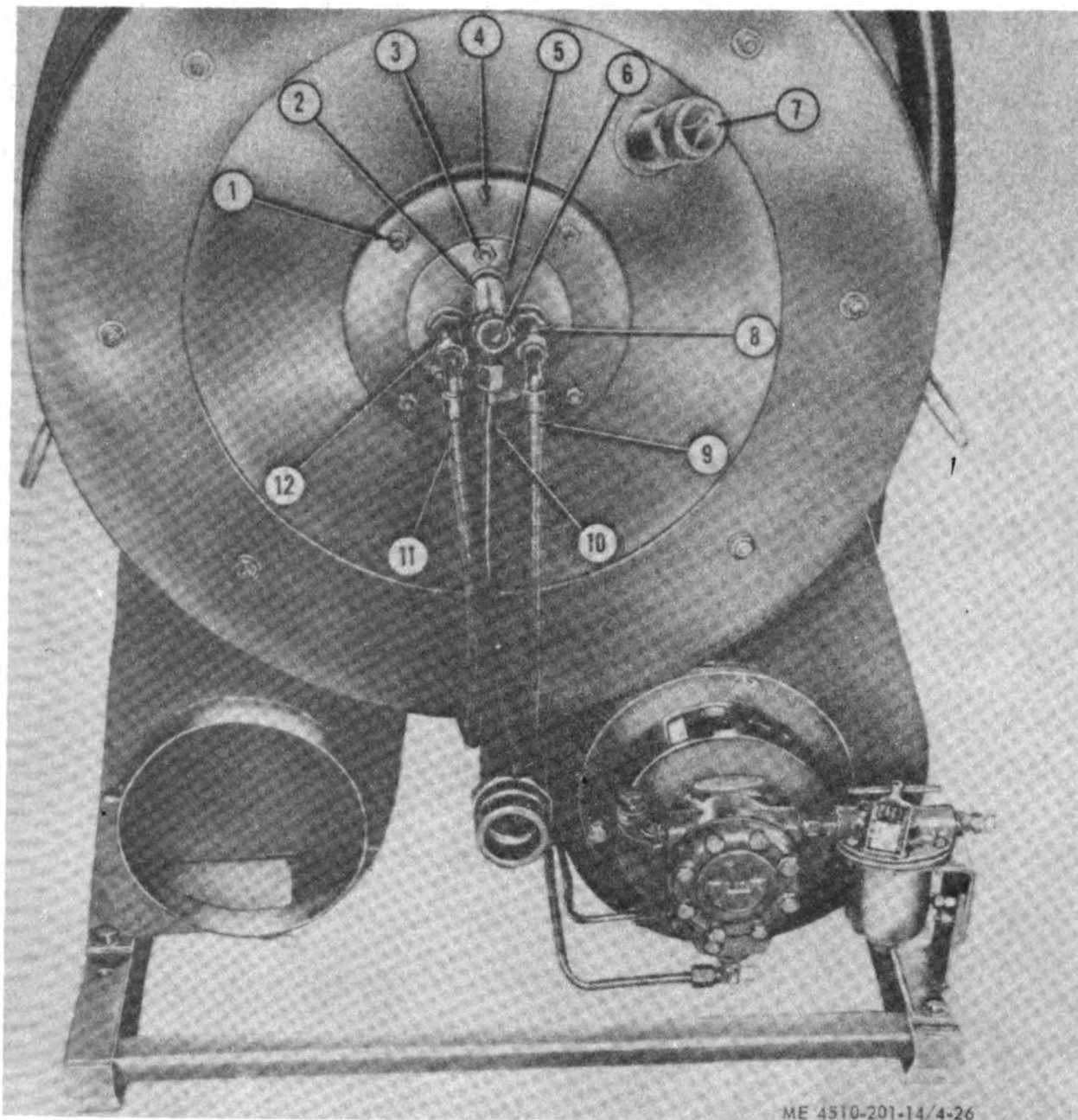
(2) *Electrode sight tube glass, gasket and bushing.* Replace defective items with serviceable ones, and install them by reversing the procedure in *b* (2) above.

(3) *Drain cock (combustion chamber).* Replace a defective drain cock with a serviceable one, and install it by reversing the procedure in *b* (3) above.

(4) *Burner electrodes, holder and gaskets.* Replace defective items with serviceable ones, and install them by reversing the procedure in *b* (4) above.

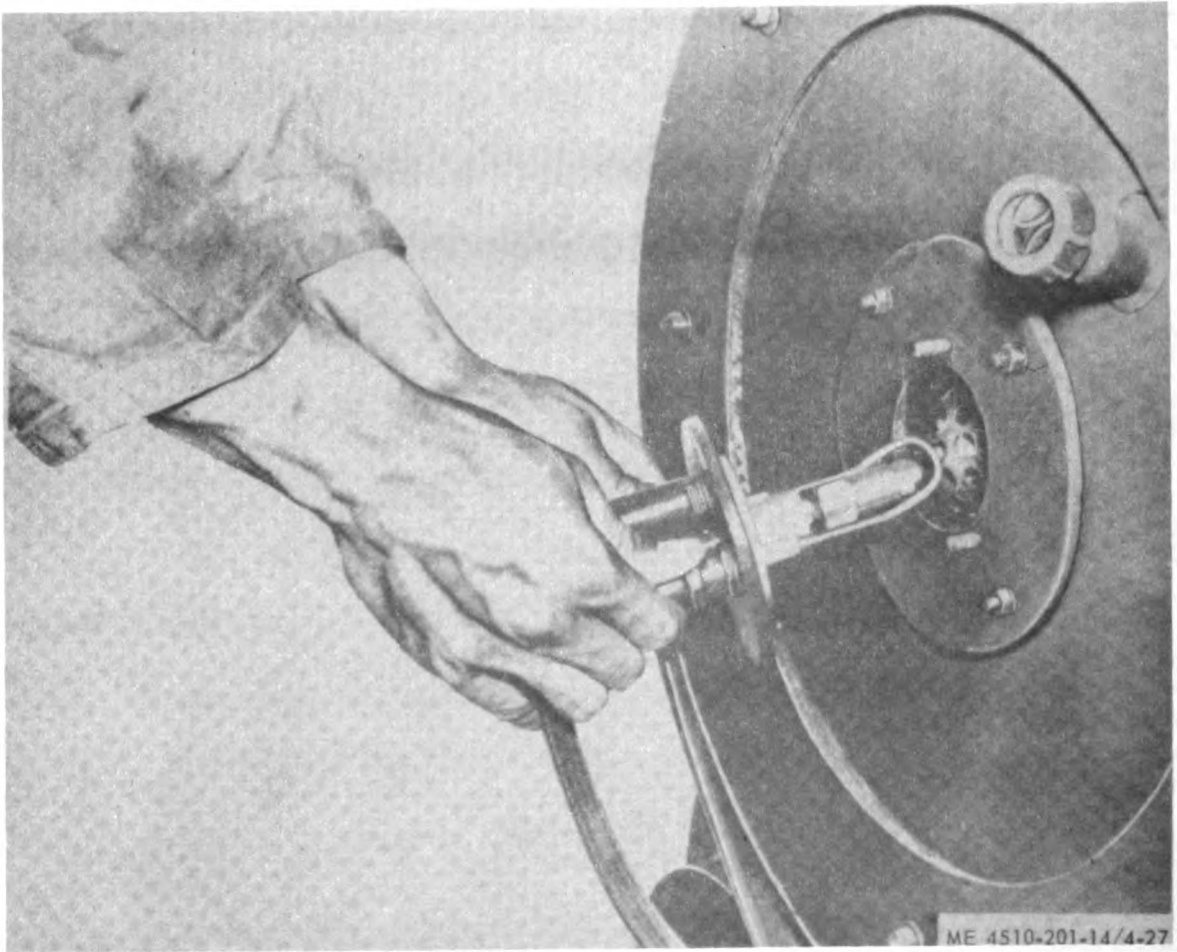
(5) *Burner fuel nozzle, adapter and nipple.* Replace defective parts with serviceable ones, and install them by reversing the procedure in *b* (5) above.

(6) *Burner head gasket and air nose.* Install serviceable items by reversing the procedure in *b* (6) above. Adjust the electrodes according to the instructions in *e* above.

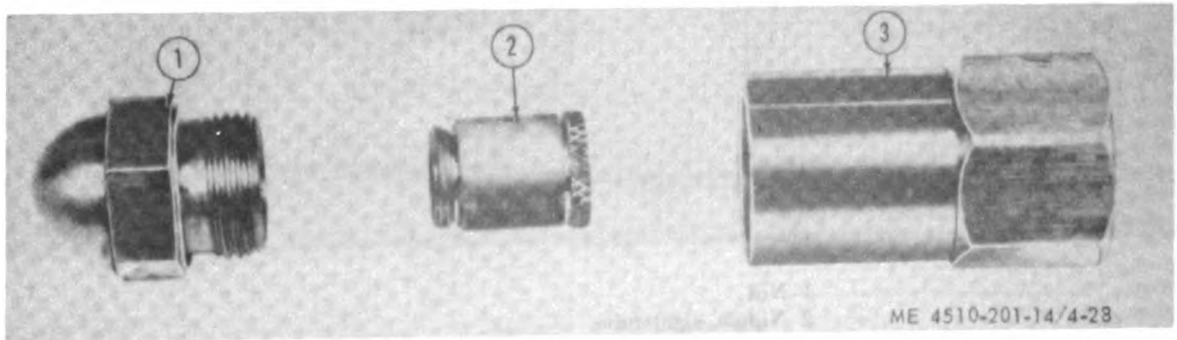


- 1 Nut
- 2 Nipple, sight tube
- 3 Nut
- 4 Burner assembly
- 5 Holder, burner and electrode
- 6 Glass, sight tube
- 7 Cap assembly, burner sight gage
- 8 Electrode, burner
- 9 Cable assembly, ignition
- 10 Line assembly, fuel feed
- 11 Cable assembly, ignition
- 12 Electrode, burner

*Figure 4-26. Water heater, left-end view.*



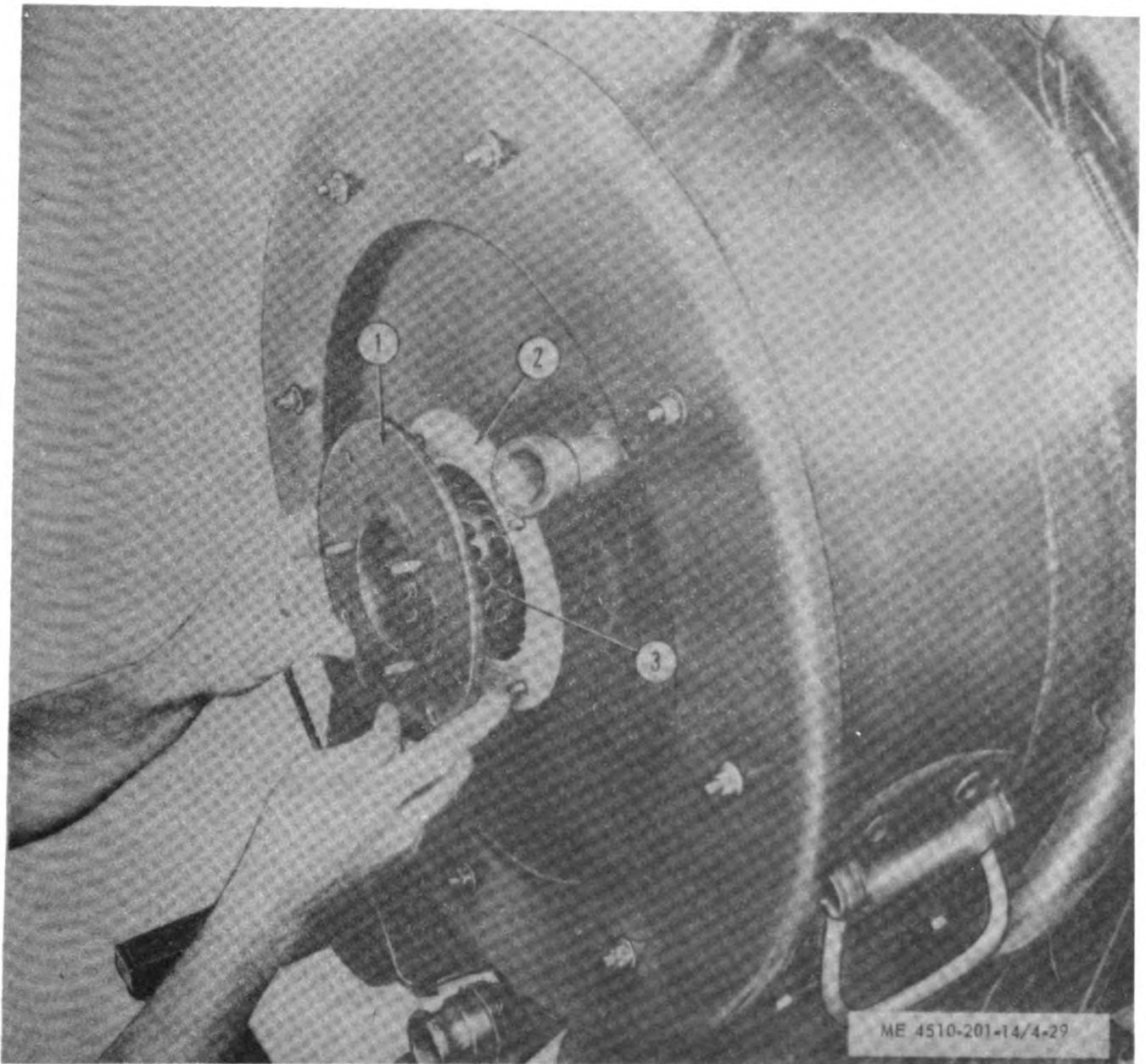
**Figure 4-27. Electrodes and holder, removed from burner assembly.**



- 1 Nozzle
- 2 Screen
- 3 Adapter

**Figure 4-28. Burner fuel nozzle, disassembled.**

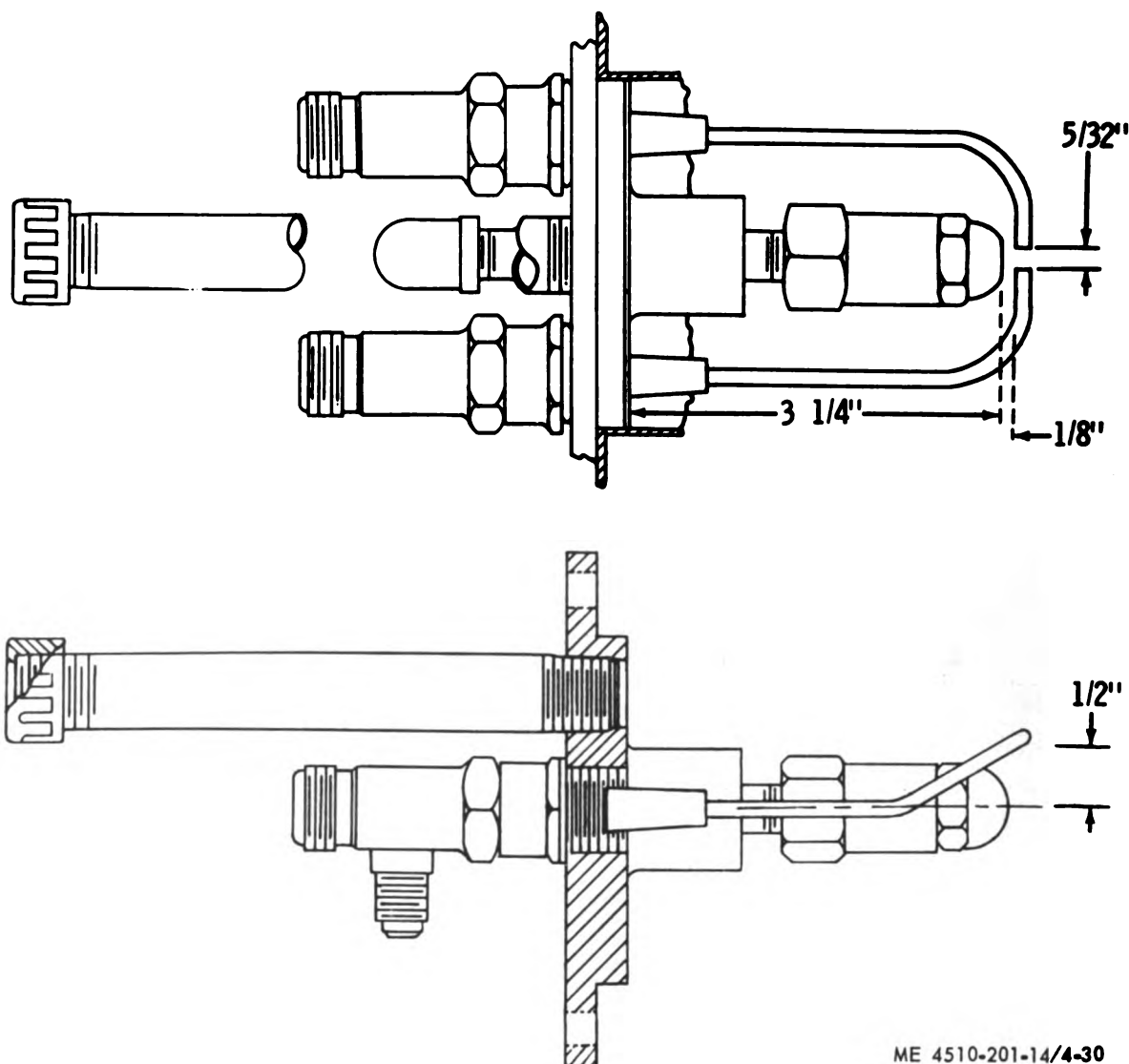




- 1 Head, burner
- 2 Gasket
- 3 Noze, air

*Figure 4-29. Burner head removed from water heater.*





ME 4510-201-14/4-30

Figure 4-30. Burner electrode spark gap adjustment.

#### 4-34. Upper Manifold Relief Valve And Elbows (Used Only On Army Models SPE 41, SPE 44, SPE 45 and York-Shipley Model YS49279)

*a. Description.* This valve (2, fig. 4-31) is located on the water heater upper manifold and adjacent to the water temperature gage sensing element. If the pressure in the water heater exceeds 60 pounds per square inch, the valve opens automatically to relieve the excess pressure.

*b. Inspection.* Inspect for broken, bent, or cracked valve and elbows.

#### *c. Removal.*

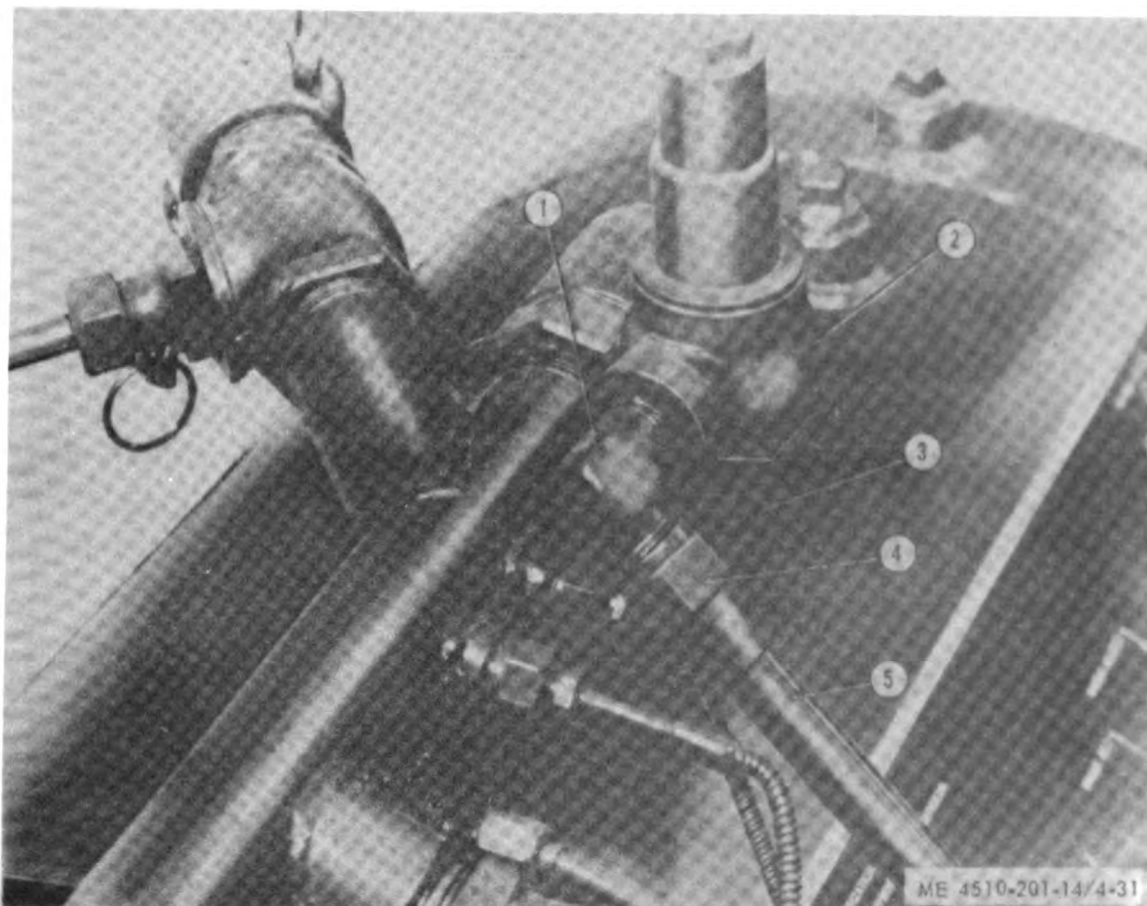
(1) Remove the nut (4, fig. 4-31) that secures the tube (5) to the elbow (1).

(2) Unscrew and remove the elbow (1) from the relief valve (2).

(3) Unscrew and remove the relief valve from the street elbow (3).

(4) Unscrew and remove the street elbow from the upper heater manifold.

*d. Installation.* Replace defective relief valve and elbows with serviceable ones, and install them by reversing the procedure in *c* above.



- 1 Elbow
- 2 Valve, relief
- 3 Elbow, street
- 4 Nut
- 5 Tube, overflow

*Figure 4-31. Upper manifold relief valve (used on Army models SPE 41, SPE 44, SPE 45 and York-Shipley YS49279).*

#### **4-35. Pressure Relief Valve Overflow Tube and Clip**

*a. Inspection.* Inspect for broken and twisted tube, and for broken and loose clip.

*b. Removal.*

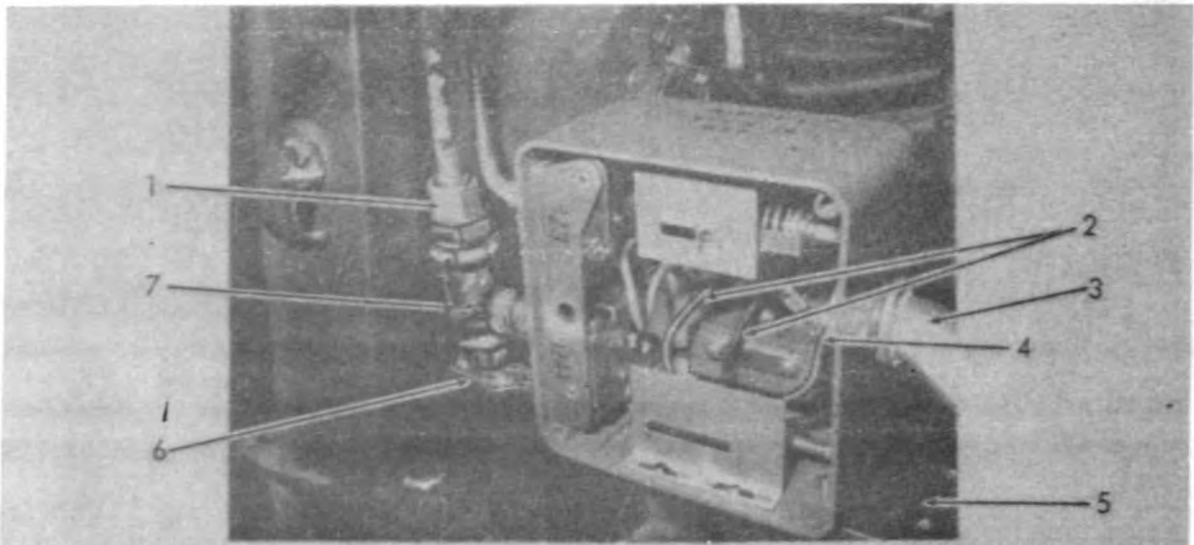
(1) Unscrew and remove the nut (4, fig. 4-31) from the elbow (1), and remove the overflow tube (5) from the elbow.

(2) Remove the nut, lockwasher, and screw

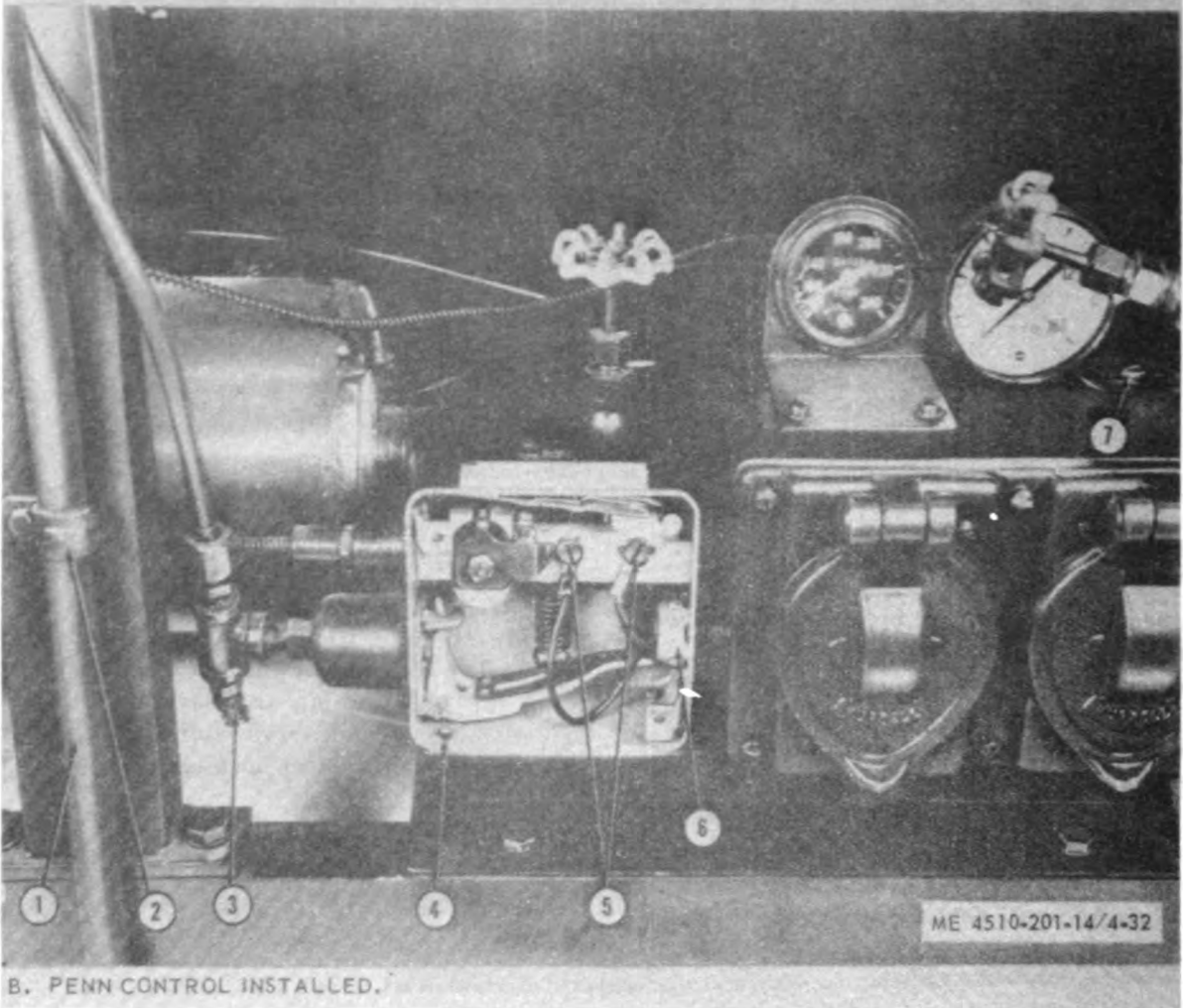
that hold the clip (2, fig. 4-32B) to the heater, and remove the clip from the heater.

(3) Remove the tube from the heater.

*c. Installation.* Replace defective tube and clip with serviceable ones. Fabricate a serviceable tube from the bulk tubing the same length as the defective one. Install serviceable tube and clip by reversing the procedure in *b* above.



A. YORK-SHIPLEY CONTROL INSTALLED.



B. PENN CONTROL INSTALLED.

**Figure 4-32. Water heater pressure and temperature control with cover removed.**

**KEY TO figure 4-32:**

- 1 Coupling
- 2 Wires
- 3 Conduit, offset
- 4 Locknut, electrical
- 5 Base, mounting
- 6 Bleed assembly
- 7 Tee, pipe

**A. York-Shipley Control Installed**

- 1 Tube, overflow
- 2 Clip
- 3 Bleed assembly
- 4 Screw, mounting
- 5 Screws, wire terminal
- 6 Locknut, pipe nipple
- 7 Valve, solenoid

**B. Penn Control Installed**

**4-36. Bypass Hose**

*a. Inspection.* Inspect for deteriorated and cracked bypass hose (1, fig. 4-33).

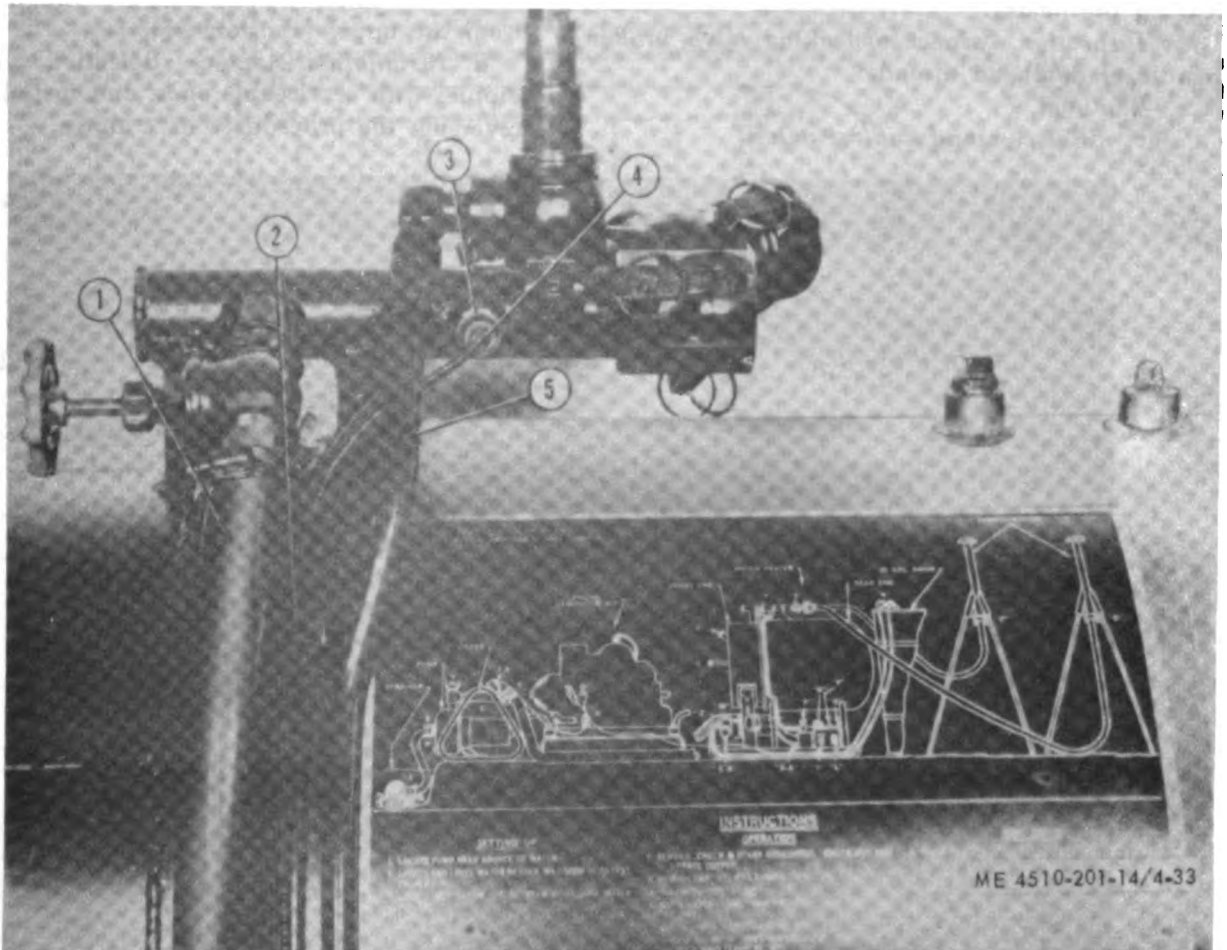
*b. Removal.*

(1) Loosen the hose clamp that holds the bypass hose to the water blender valve.

(2) Loosen the clamp that holds the hose to the lower water manifold.

(3) Remove the hose from the heater.

*c. Installation.* Replace defective hose with a serviceable one. Fabricate a serviceable hose from the bulk hose the same length as the defective one. Install serviceable hose by reversing the procedure in *b* above.



- 1 Hose, water heater bypass
- 2 Clip
- 3 Bushing
- 4 Nut
- 5 Tube, sensing

*Figure 4-33. Water heater upper manifold.*

#### 4-37. Shower Stand Control and Water Blender Valves

##### a. Description.

(1) *Shower stand control valve.* On Army models SPE 35 and SPE 35A, the shower stand control valve (4, fig. 4-34) is located on the upper manifold on top of the water heater. On Army model SPE 41, SPE 44, SPE 45 and York-Shipley model YS49279, the control valve is located on the upper manifold outlet opposite from that shown in figure 4-34.

(2) *Water blender valve.* The water blender valve (8) is located on top of the water heater and in the bypass hose line just ahead of the line that goes into the upper manifold. This valve allows cold water, coming directly from the water source, to enter the manifold and to mix with the heated water leaving the heater.

b. *Inspection.* Inspect for leaking valve, broken handle or damaged threads.

##### c. Removal.

(1) *Shower stand control valve.*

(a) Unscrew and remove the coupler (2) from the end of the shower stand control valve (4).

(b) Unscrew the packing nut (3) from the valve, and remove the valve handle and the stem from the valve body.

(c) Unscrew and remove the valve body from the upper manifold (1).

(2) *Water blender valve.*

(a) Loosen the clamp, and remove the hose (6) from the nipple (5).

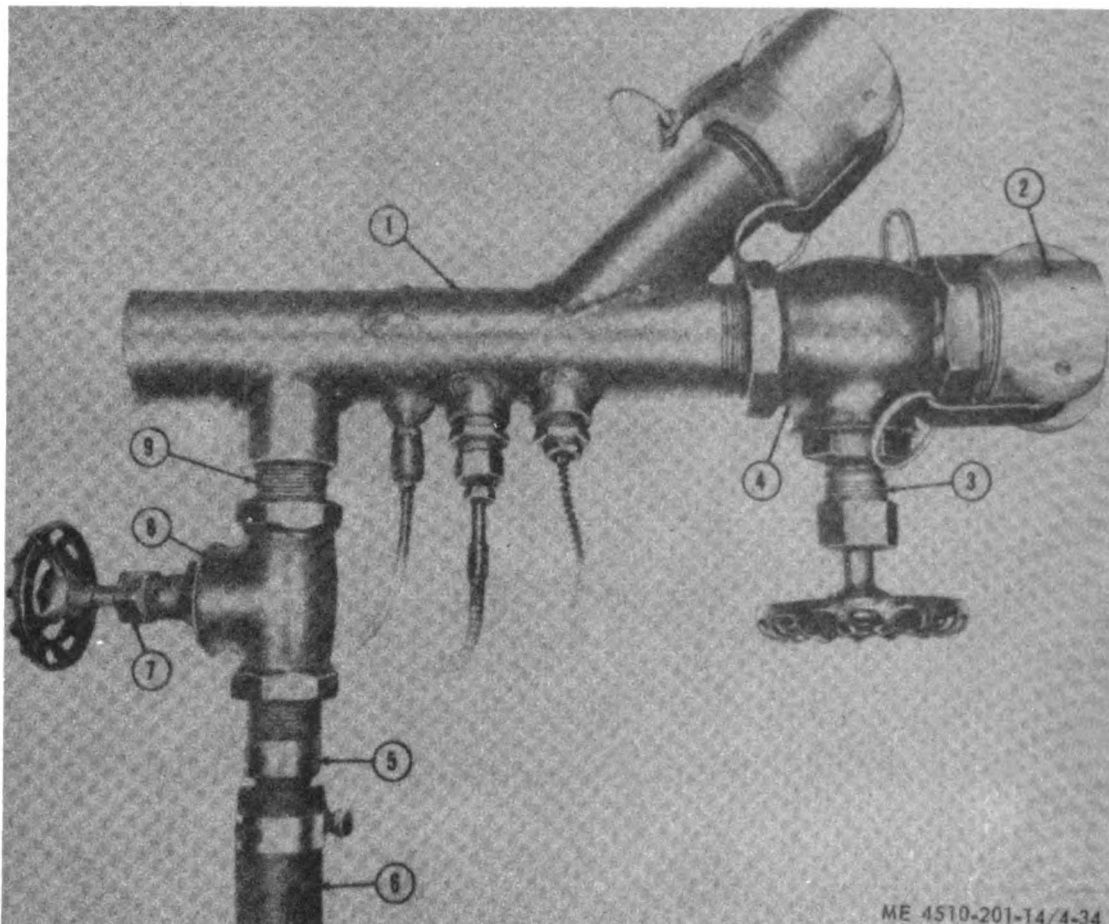
(b) Unscrew and remove the nipple (5) from the water blender valve (8).

(c) Unscrew and remove the packing nut (7) from the blender valve, and remove the valve handle and the stem from the body of the valve.

(d) Unscrew and remove the blender valve from the nipple (9).

(e) Unscrew and remove the nipple (9) from the upper manifold (1).

d. *Installation.* Replace defective valves or nipples with serviceable ones, and install them by reversing the procedures in c above.



- 1 Manifold, upper
- 2 Coupler
- 3 Gland, packing
- 4 Valve, shower stand control
- 5 Nipple

- 6 Hose, bypass
- 7 Nut, packing
- 8 Valve, water blender
- 9 Nipple

Figure 4-34. Shower stand control and water blender valves.

#### 4-38. Welded Tank

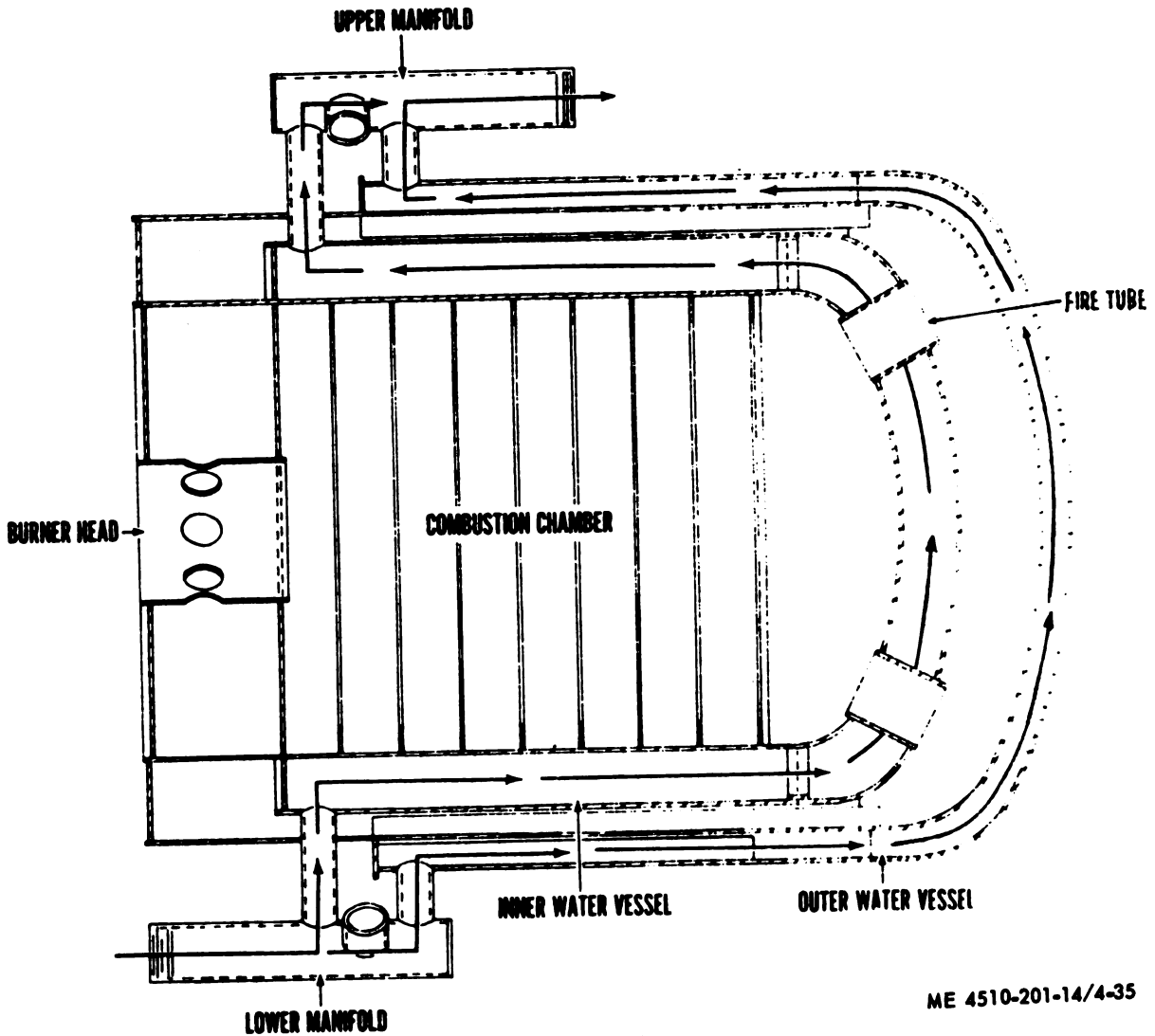
a. *Description.* The tank is a container designed to heat the incoming water to a temperature suitable for showers. The inside of the tank is equipped with an inner water-heating vessel and an outer water-heating vessel (fig. 4-35). These vessels form a combustion chamber inside the tank. Openings in the rear of the inner water-heating vessel allow the combustion gases to flow into the

area between the two vessels and then out through the exhaust duct opening.

b. *Servicing.* Clean the tank with a moist cloth.

c. *Inspection.* Inspect the tank for dents, breaks, cracks, and leaks. Make certain all weld spots are complete and unbroken. Be sure the upper and the lower manifolds are welded securely to the tank.

d. *Replacement or Repair.* Refer to paragraph 6-10.



ME 4510-201-14/4-35

Figure 4-35. Schematic drawing showing inside of water heater tank.

#### 4-39. Bath Unit Instructional Plate

*a. Description.* The instruction plate (fig. 1-2) mounted on the water heater, provides a schematic layout of the bath unit. It also provides the basic instructions for operating the bath unit.

*b. Inspection.* Inspect for broken or cracked instruction plate. Make certain the instructions on the plate are legible and that all edges of the plate are mounted securely to the heater tank.

*c. Removal.* Pry up the edges of the plate, and remove the plate from the tank.

*d. Installation.* Replace defective plate with a serviceable one. Apply a coating of the adhesive (supplied with the plate) to the back of the plate, and attach and press the plate on the tank. Be sure to press the plate down firmly.

#### 4-40. Water Heater Control Assembly

*a. Control Panel Switch Cover with Hinged Cover and Gasket.*

(1) *Description.* The instructions in this paragraph pertain either to the water heater control panel switch cover or the water pump control panel switch cover.

(2) *Inspection.* Inspect the switch cover (6, fig. 4-22) for breaks, cracks, distortions, and twists, and poor fit on the box. Check for broken hinged spring. Lift up the cover to check for deteriorated and excessively worn gasket.

(3) *Removal.* Remove the four screws (7) that attach the switch cover (6) to the control panel box cover (5), and remove the cover and the gasket from the box.

(4) *Installation.* Replace defective cover and gasket with serviceable ones, and install them by reversing the procedure in *a* (3) above.

*b. Control Panel Box and Cover.*

(1) *Description.* The instructions in this paragraph pertain either to the water heater control panel box cover or the water pump control panel box cover.

(2) *Inspection.* Inspect the cover (5) for breaks, cracks, distortions, and twists, and poor fit on the box. Check for deteriorated or excessively worn gasket.

(3) *Removal.*

(*a*) Remove the six screws (1) that hold the cover (5) to the control panel box (4) and remove the cover with circuit breaker subassembly (5, fig. 4-36) and receptacle connector (8) from the box.

(*b*) Remove the circuit breaker subassembly as follows:

1. Remove the screws (1, fig. 4-22) that secure the control panel box cover (5) to the box (4), and separate the cover from the box.

2. Remove the screws (6, fig. 4-36) that secure the circuit breaker subassembly (5) to the cover (5, fig. 4-22), and separate the subassembly from the cover.

(*c*) Refer to *a* (3) above, and remove the control panel switch cover with hinged cover and gasket.

(*d*) Remove the receptacle connector by referring to *c* (2) below.

(*c*) Remove the gasket (7, fig. 4-36) from the control panel box.

(4) *Installation.* Replace defective cover and gasket with serviceable ones, and install them by reversing the procedure in *b* (3) above.

*c. Control Box Receptacle Connector With Gasket and Hinged Cover.*

(1) *Description.* The instructions in this paragraph pertain to the receptacle connectors either on the water heater or on the water pump.

(2) *Removal.*

(*a*) Remove the four screws that attach the connector with cover to the control panel box cover (5, fig. 4-22).

(*b*) Raise the hinged cover, then remove the insulator from the connector (8, fig. 4-36).

(*c*) Loosen the four screws that hold the wires to the connector, and remove the wires from the connector, thus freeing the connector with gasket and hinged cover.

#### NOTE

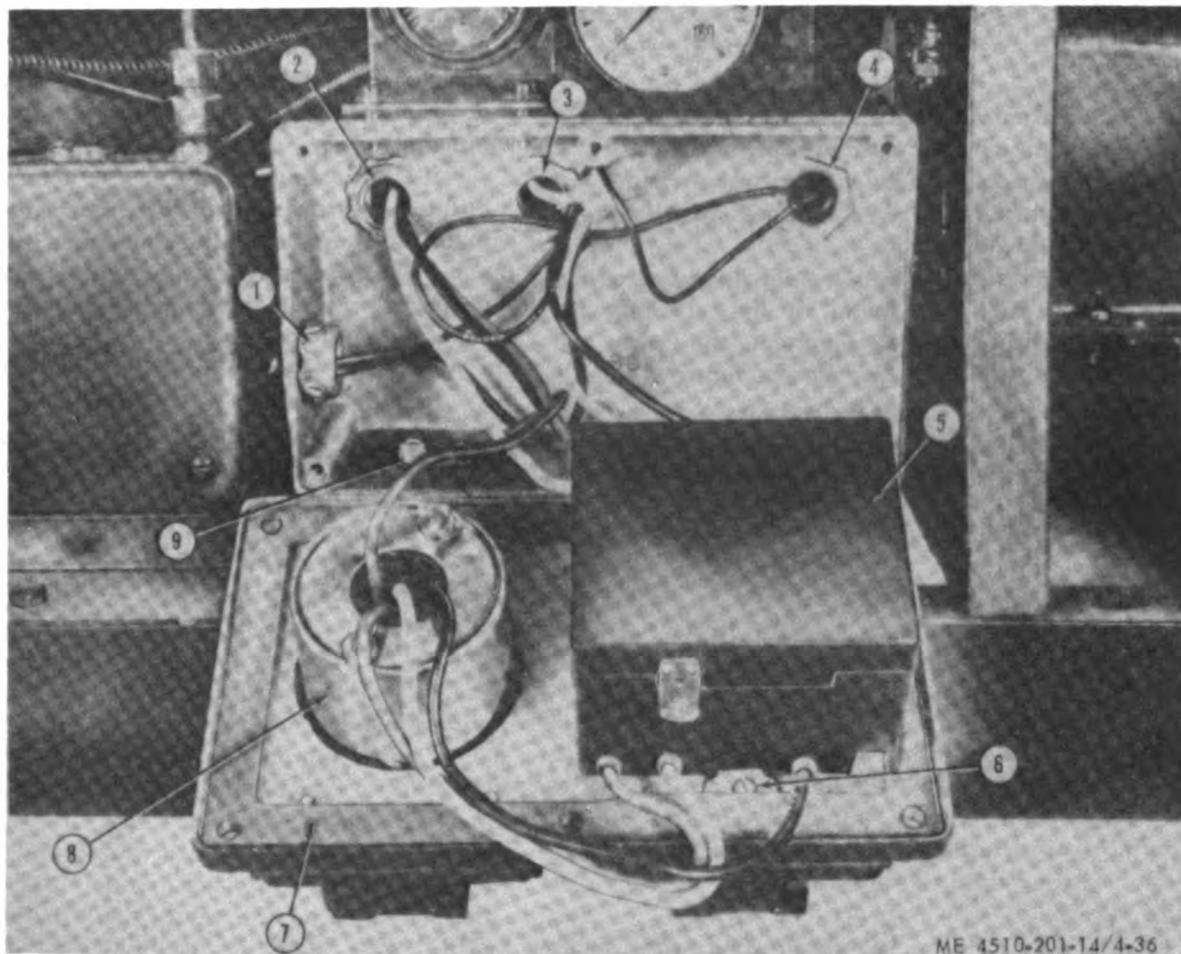
Tag the wires for identification if color-coded wires are not used.

(3) *Inspection.* Inspect the connector for bent or twisted prongs, stripped threads, broken or frayed insulation, deteriorated gasket, and broken hinged cover.

(4) *Installation.* Replace defective connector with a serviceable one, and install it by reversing the procedure in *c* (2) above. Connect the wires according to the diagram in figure 4-23 for the water heater and according to the diagram in figure 4-15 for the water pump.

*d. Control Panel Circuit Breaker Subassembly and Circuit Breaker Subassembly Overload Heaters.* For maintenance information, refer to paragraph 4-27 *a* and paragraph 4-27 *b*.





- 1 Locknut, panel box-to-pressure control nipple
- 2 Nut, lower motor conduit tube
- 3 Nut, transformer conduit tube
- 4 Connector, box
- 5 Subassembly, circuit breaker
- 6 Screw
- 7 Gasket, control box cover
- 8 Connector, receptacle
- 9 Nut

Figure 4-36. Water heater control panel box with cover removed.

**e. Water Heater Control Panel Box.**

**(1) Removal.**

(a) Refer to paragraph 4-27 a (2), and remove the circuit breaker subassembly.

(b) Refer to paragraph 4-40 c (2), and remove the control box receptacle connector.

(c) Disconnect the two wires connected to the pressure and temperature control.

**NOTE**

Tag the wires for identification if color-coded wires are not used.

(d) Remove the locknut (1, fig. 4-36) that attaches the pressure and temperature control (12, fig. 4-22) to the panel box (4).

(e) Remove the conduit nuts (2 and 3, fig. 4-36) that attach the conduits to the panel box.

(f) Remove the box connector (4) that attaches the solenoid valve to the panel box.

(g) Remove the nuts and screws that attach the water temperature gage bracket to the panel box, and separate the bracket from the panel box.

(h) Remove the nuts (9) and the ground wire from the capscrews that hold the panel box to the panel box bracket (11, fig. 4-22).



**NOTE**

Tag the wires for identification if color-coded wires are not used.

(i) Remove the panel box (4) from the bracket, sliding it over the ends of the wires.

(2) *Inspection.* Inspect for broken panel box and for damaged threads. Check for improper closure of the cover.

(3) *Installation.* Replace defective box with a serviceable one, and install it by reversing the procedures in *b* above. Connect the wires according to the wiring diagram in figure 4-23.

**NOTE**

Make sure the green ground wire is properly connected before the panel box cover is installed.

*f. Water Heater Pressure and Temperature Control.*

(1) *Description.* The pressure and temperature control (12, fig. 4-22) is located beside the water heater control panel box. It is an automatic safety control. It prevents the burner from being fired until water is in the heater, and it prevents water that is above 120° F. from being supplied to the shower head nozzles. When the pressure of the incoming water reaches 10 pounds per square inch, the pressure contacts in the control close. This action causes the solenoid valve (4-40*i*) to open and, thereby, allows fuel to be supplied to the burner. When, during operation, the water temperature exceeds 120° F., the temperature contacts open. This action causes the solenoid valve to close and, thereby, stops the flow of fuel to the burner.

(2) *Removal.*

(a) Disconnect the temperature sensing element from the water heater upper manifold, and remove the capillary tube from the clips on the water heater.

(b) Disconnect the pressure sensing line connection at the top of the pipe tee (3, fig. 4-32).

(c) Remove the tee from the pressure and temperature control (12, fig. 4-22).

(d) Loosen the two screws that hold the cover to the pressure and temperature control, and remove the cover as shown in figure 4-32.

(e) Loosen the two wire terminal screws (5), and remove the wires.

**NOTE**

Tag the wires for identification if color-coded wires are not used.

(f) Remove the locknut (6) from the nipple on the inside of the pressure and temperature control.

(g) Tilt the water heater to get access to the four screws (4) that hold the pressure and temperature control to the bracket (11, fig. 4-22), and remove the screws from the control.

(h) Remove the pressure and temperature control from the bracket.

(3) *Inspection.* Inspect the control for burned or damaged contacts and for broken or bent housing.

(4) *Installation.* Replace a defective pressure and temperature control with a serviceable one, and install it by reversing the procedure in *f* (2) above.

(5) *Adjustment.* Refer to paragraph 6-11 for information in adjusting the pressure and temperature control.

*g. Water Heater Control Panel Box Bracket.*

(1) *Removal.*

(a) Remove the six screws (1, fig. 4-22) that hold the control panel box cover (5) to the control panel box (4), and remove the cover and gasket from the box.

(b) Remove the four screws that hold the pressure and temperature control (12) to the control panel box bracket (11).

(c) Remove the nuts from the capscrews that hold the control panel box (4) to the bracket, and remove the capscrews from the box.

(d) Remove the nuts and lockwashers from the capscrews (10), and remove the capscrews from the bracket and from the skid.

(e) Slide the bracket from under the pressure and temperature control and from under the control box, and remove the bracket from the skid.

(2) *Inspection.* Inspect for bent, broken, and cracked bracket.

(3) *Installation.* Replace defective bracket with a serviceable one, and install it by reversing the procedure in *g* (1) above.

*h. Changeover Procedure From Penn Pressure Temperature Control to New York-Shipley Control Conversion Kit.*

(1) *Disassembly.*

(a) Disconnect electrical connections and remove old control, including temperature bulb.

(b) Remove bleed assembly (3, fig. 4-32) from old control.

(2) *Reassembly.*

(a) Assemble bleed assembly (fig. 4-37A) to new temperature-pressure control using 1/8 IPS x 3/4 inch long nipple.

(b) Install temperature-pressure control assembly (inserting offset conduit into electrical connection of switch box (fig. 4-37B).

(c) Attach control assembly to mounting base using four (4) No. 10-24 x 1/4 inch roundhead screws and four (4) No. 10 internal tooth lockwashers.

(d) Assemble electrical locknut and conduit bushing to end of offset conduit in switch box.

(e) Feed wires through offset conduit into pressure-temperature control.

(f) Connect wires to terminals in pressure-temperature control (fig. 4-37B).

(g) Reconnect aluminum tubing line to bleed assembly.

(h) Insert  $\frac{3}{8}$  IPS x 1 inch long pipe nipple into header connection previously used for temperature control bulb.

(i) Thread  $\frac{3}{8}$  IPS x  $\frac{1}{2}$  inch IPS reducing ell onto nipple.

(j) Remove  $\frac{1}{2}$  inch pressure relief valve and street ell from header. Street ell will not be required with new arrangement. Reinstall the pressure relief valve in the  $\frac{3}{8}$  x  $\frac{1}{2}$  inch reducing ell.

(k) Attach drain line to discharge of pressure relief valve.

(l) Using compression fitting, install temperature bulb into connection previously used for the pressure relief valve (fig. 4-37C).

(m) Tighten compression fitting packing nut.

(3) *Test Operation.*

(a) Operate water pump and check all connections for water leaks.

(b) Connect fuel and electrical supply lines.

(c) Turn fuel pump motor switch on and check fuel lines for leaks.

(d) Open fuel shutoff valve and fire heater at maximum firing rate (100 PSIG pressure on fuel pressure gauge).

(e) Observe water temperature gauge. Fuel solenoid valve will be de-energized when water temperature reaches a temperature of about 120°F.

(f) Fuel solenoid valve will be energized when water temperature is 90°F.

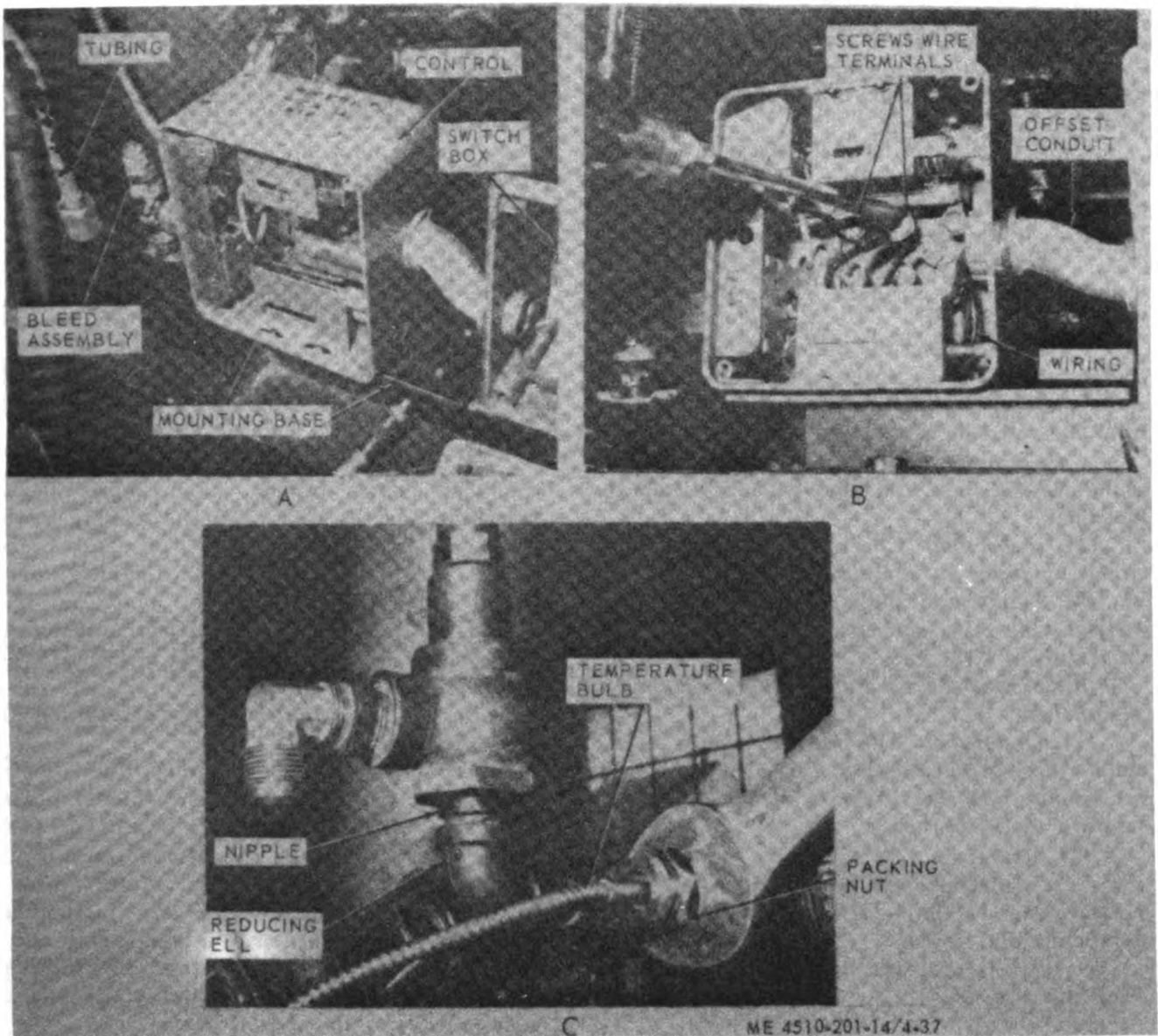


Figure 4-37. Installation of York-Shipley pressure and temperature control.

*i. Water Heater Burner Solenoid Valve.*

(1) *Description.* The burner solenoid valve (7, fig. 4-32) is located behind the water heater control panel box. It is automatic and is controlled by the pressure and temperature control. Refer to *e* and *f* above. It regulates the flow of fuel to the burner nozzle. When water is supplied to the heater, it creates a pressure, which closes the switch in the pressure and temperature control and energizes the solenoid valve. If the temperature of the shower water rises above 120° F., the switch in the pressure and temperature control breaks contact and de-energizes the solenoid valve, which stops the flow of fuel to the burner. When the temperature of the shower water drops to 95° F., the switch in the pressure and temperature control closes and energizes the solenoid valve, and allows fuel to flow to the burner.

(2) *Removal.*

(a) Remove the six screws (1, fig. 4-22) that hold the control panel box cover (5) to the control panel box (4), and remove the cover and gasket from the box.

(b) Loosen the two screws that hold the pressure and temperature control cover to the pressure and temperature control (12), and remove the cover from the control.

(c) Disconnect the valve wire from the wire terminal screw (5, fig. 4-32) in the pressure and temperature control.

(d) Disconnect the other valve wire in the control panel box by unscrewing the wire nut.

(e) Unscrew and remove the box connector from the solenoid valve (7).

(f) Disconnect the pipe fittings at both sides of the solenoid valve, and remove the valve from the fuel line.

(3) *Inspection.* Check the valve for open circuit by using an ohmmeter.

(4) *Installation.* Replace defective valve with a serviceable valve, and install it by reversing the procedure in *i* (2) above.

*j. Water Heater Fuel Pump Pressure Gage and Dampener.*

(1) *Description.* The pressure gage is located behind the control panel box. It registers in pounds per square inch the pressure of the fuel being supplied to the burner.

(2) *Removal.*

(a) Unscrew and remove the fuel pump pressure gage (3, fig. 4-22) from the fluid pressure dampener (fig. 4-19).

(b) Unscrew and remove the dampener from the pipe tee.

(3) *Inspection.* Inspect the gage and the dampener for damaged threads, and the gage for broken or scratched glass, illegible markings, and broken hand.

(4) *Installation.* Replace defective gage and dampener with serviceable ones, and install them by reversing the procedure in *j* (2) above. Make certain the gage dial faces the front of the water heater.

*k. Water Heater Temperature Gage, Bracket, and Bushing.*

(1) *Description.* The water heater temperature gage is mounted on the gage bracket on the heater control panel box. It indicates the temperature of the water being supplied to the shower stands.

(2) *Removal.*

(a) Unscrew the nut (4, fig. 4-33) and remove the sensing bulb from the bushing (3), and unscrew and remove the bushing from the manifold.

(b) Remove the sensing tube (5) from the retaining clips (2) on the water heater.

(c) Remove the six screws that hold the cover (5, fig. 4-22) to the control panel box, and remove the cover and gasket from the box.

(d) Remove the nuts and the screws that attach the temperature gage bracket to the panel control box (4).

(e) Remove the bracket with the temperature gage (2) from the control panel box.

(f) Remove the two nuts that hold the bracket to the gage to separate the bracket from the gage.

(3) *Inspection.* Inspect the gage for broken or scratched glass, broken hand, and illegible markings. Inspect for broken and leaking sensing tube and bulb. Inspect for bent and broken bracket, and check for stripped or damaged threads on the bushing.

(4) *Installation.* Replace defective items with serviceable ones, and install them by reversing the procedure in *k* (2) above.

*l. Burner Fuel Control Valve or Burner Fuel Shutoff Valve.*

(1) *Description.* The burner fuel control valve is located above the water heater control panel box. It is used to adjust the flow of fuel to the burner thus controlling the temperature of the shower water. The burner fuel shutoff valve is located behind the pressure and temperature control on the water heater. It is used to start and to stop the flow of fuel to the burner. The following instruction in this paragraph applies either to the control valve or the shutoff valve.

**(2) Removal.**

**(a) Unscrew the nut, and remove the fuel line on the tee side of the valve (fig. 4-19).**

**(b) Unscrew and remove the valve from the pipe fitting.**

**(3) Inspection.** Inspect the valve for worn packing and for damaged threads.

**(4) Installation.** Replace defective valve with a serviceable valve, and install it by reversing the procedure in *l* (2) above.

***m. Blower Motor Conduit Tube and Wires.***

**(1) Removal.**

**(a) Remove the six screws that hold the cover (5, fig. 4-22) to the control panel box (4), and remove the cover.**

**(b) Remove the motor wire nuts that hold the two motor wires together, and separate the wires from each other.**

**(c) Remove the conduit tube nut that holds the conduit tube to the control panel box.**

**(d) Loosen the nut that holds the conduit tube to the elbow on the motor, and slide the tube from the water heater.**

**(2) Inspection.** Inspect the tube for breaks, cracks, and damaged threads. Inspect the wires for breaks and frayed insulation. If the wires are defective, remove the motor access plate, located at the motor end opposite the shaft end, and disconnect the wires leading to the motor.

**(3) Installation.** Replace defective wires with serviceable ones. Connect the wires according to the wiring diagram shown in figure 4-23, using wire nuts to connect the motor wires at the motor, and then install the motor access plate. Replace defective tube with a serviceable one, and install the tube by reversing the procedure in *m* (1) above.

***n. Pressure Control Line Drain Cock.***

**(1) Description.** This drain cock is used to drain the water from the pressure control line.

**(2) Removal.** Unscrew and remove the drain cock from the pressure control line pipe tee opposite the left side of the temperature and pressure control (12, fig. 4-22).

**(3) Inspection.** Inspect drain cock for damaged threads.

**4-41. Fuel Pump Assembly**

***a. Fuel Pump.***

**(1) Description.** The fuel pump is mounted to the fuel pump bracket which is mounted to the blower housing. The fuel pump is coupled to and driven by the electric motor operating the blower. The pump draws fuel from the fuel drum and delivers it to the burner at a maximum pressure of 100 pounds per square inch.

**(2) Inspection.** Inspect the pump for loose mounting and improper alignment. Inspect for cracked, broken, and leaking pump.

**(3) Removal.**

**(a) Disconnect the fuel assemblies (8 and 9, fig. 4-38) from the fuel pump (10).**

**(b) Remove the nuts, lockwashers, and bolts that hold the fuel filter bracket (4) to the skid.**

**(c) Open the shutter, and loosen the set-screw that holds the blower shaft coupling to the fuel pump.**

**(d) Remove the two capscrews (6) and the lockwasher that hold the fuel pump to the bracket.**

**(e) Remove the fuel pump with the filter (5) from the bracket.**

**(f) Unscrew and remove the filter from the nipple (2).**

**(g) Unscrew and remove the nipple from the fuel pump (10).**

**(h) Remove the tee (7) from the fuel pump.**

**(i) Remove the elbow (1) from the fuel pump.**

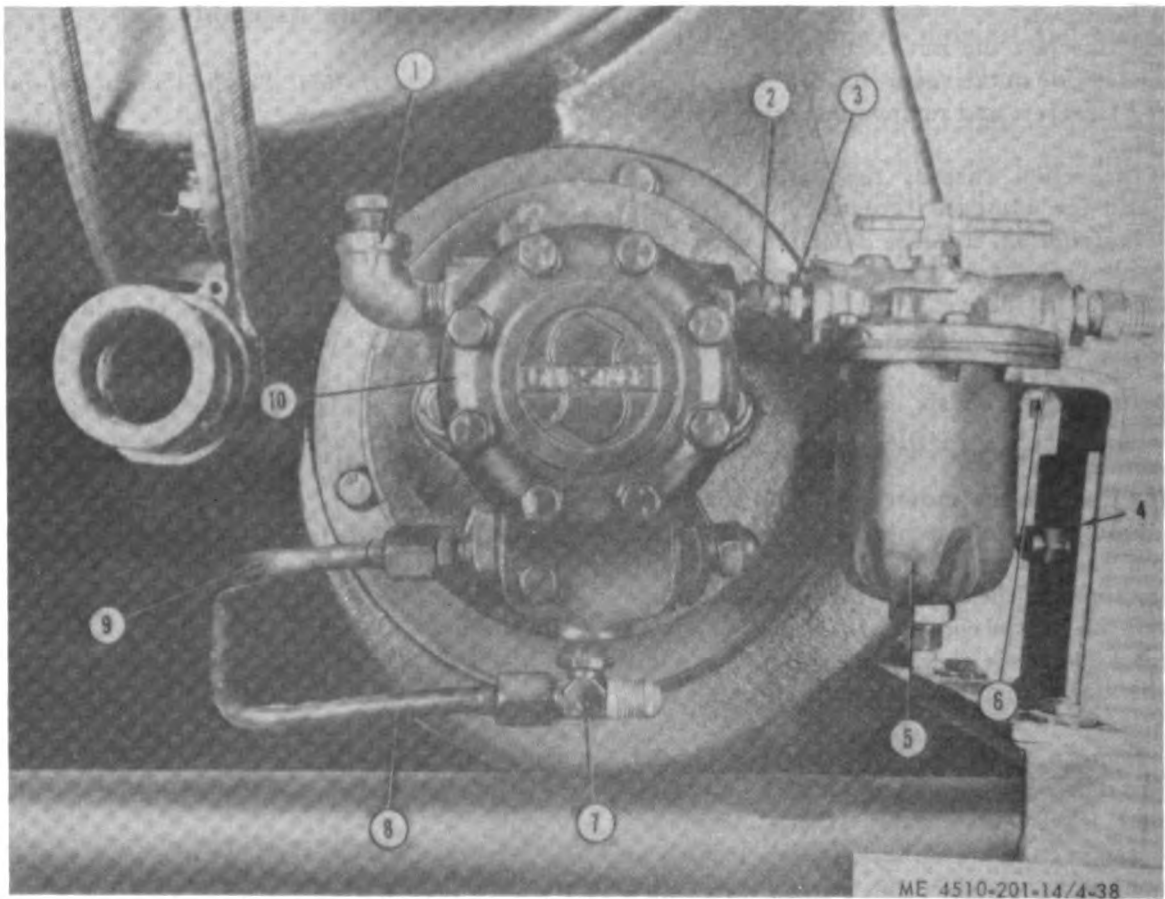
**(4) Installation.** Replace defective fuel pump with a serviceable one, and install it by reversing the procedure in *a* (3) above.

**(5) Adjustment.** Adjust the pressure on the pump to 100 pounds per square inch according to the procedures below. Adjustment must be made with the fuel pump operating.

**(a) Remove the end cap from the side of pump.**

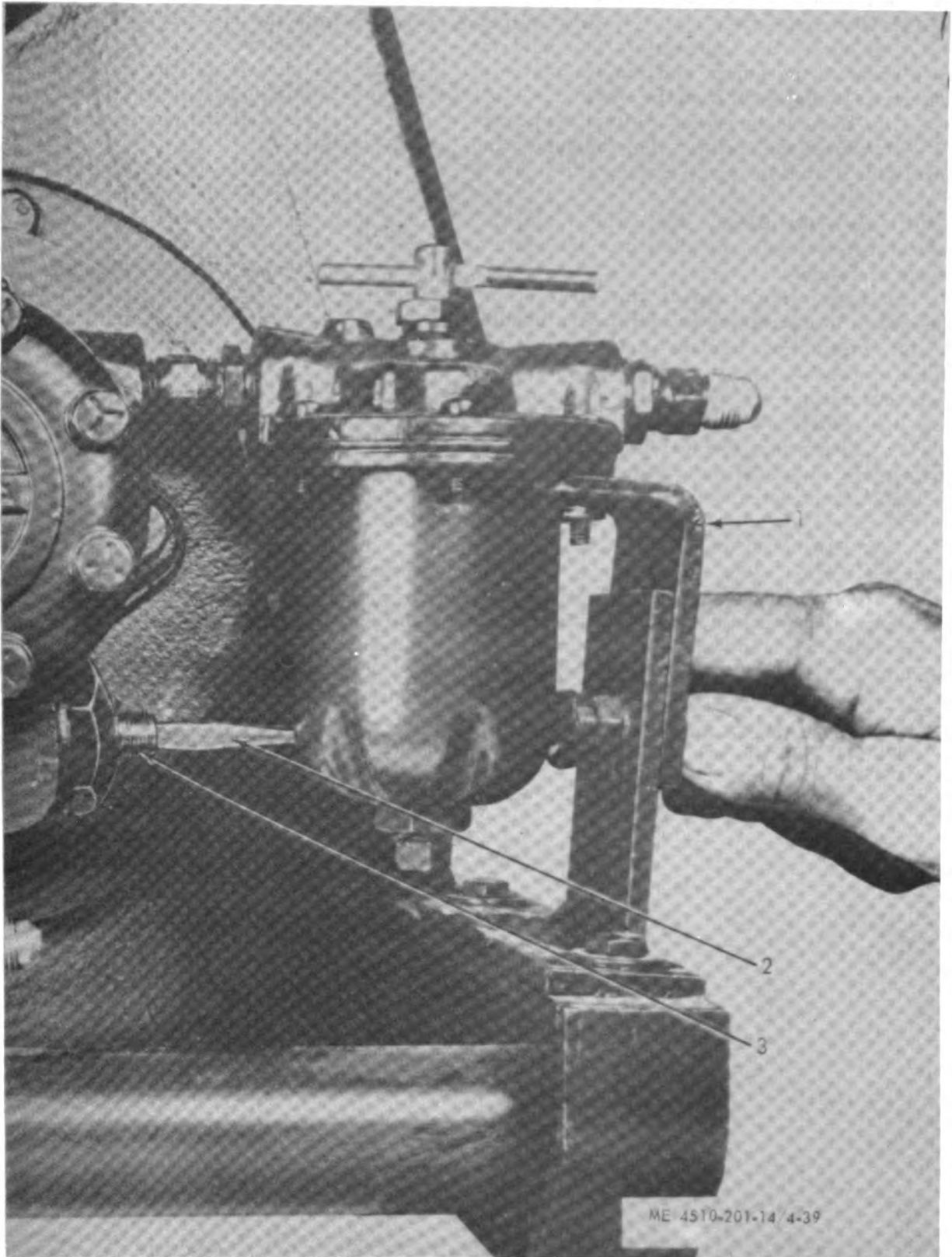
**(b) Turn the pressure regulating setscrew as shown in figure 4-39 clockwise to increase the pressure, and turn it counter-clockwise to decrease the pressure on the pump.**

**(c) Replace the end cap on the pump.**



- 1 Elbow, priming port pipe
- 2 Nipple, fuel filter-to-fuel pump pipe
- 3 Bushing, inlet and outlet
- 4 Bracket, fuel filter
- 5 Filter, fuel
- 6 Nut
- 7 Tee, fuel return pipe-to-tube
- 8 Line assembly, elbow-to-fuel pump return
- 9 Line assembly, fuel pump-to-fuel control valve tee
- 10 Pump, fuel

*Figure 4-38. Fuel pump and filter mounted on blower.*



- 1 Bracket, fuel filter
- 2 Screwdriver
- 3 Setscrew, pressure regulating

*Figure 4-39. Adjusting pressure on fuel pump.*

**b. Fuel Pump Strainer and Cover Gasket.**

**(1) Removal.**

(a) Loosen the eight screws that hold the pump cover to the pump, and remove the cover with screws (2, fig. 4-40) from the pump.

(b) Remove the gasket (3) from the pump.

(c) Grasp the strainer (1) by the handle and slowly slide it from the pump as shown in figure 4-40.

(2) *Servicing.* Clean the strainer in SD (solvent, drycleaning), and allow it to drain and to air-dry thoroughly.

(3) *Inspection.* Inspect the strainer for damaged or torn screening and for broken handle.

(4) *Installation.* Replace defective strainer with a serviceable one, and install it by reversing the procedure in b (1) above, using a new gasket.

**c. Fuel Filter and Bracket.**

(1) *Description.* The fuel filter is mounted on the lower left end of the water heater, and it is used to filter the fuel before it enters the fuel pump.

**(2) Removal.**

(a) Disconnect the fuel feed hose assembly at the fuel filter.

(b) Remove the nuts, lockwashers and bolts that secure the lower half of the fuel filter bracket (4, fig. 4-38) to the upper half of the bracket and the skid.

**NOTE**

This fuel filter bracket is used on Army models SPE 44, SPE 45 and York-Shipley model YS49279.

(c) Remove the lower half of the filter bracket from the skid.

(d) Remove the blower shutter (paras 4-44 b (3) (a) thru (c)) (Army models SPE 44, SPE 45 and York-Shipley model YS49279).

(e) Unscrew and remove the filter (5) from the nipple (2).

**(3) Disassembly.**

(a) Remove the two nuts and lockwashers that hold the upper half of the fuel filter, and remove the bracket from the filter.

(b) Remove the screws that hold the lockring to the filter head (3, fig. 4-41).

(c) Remove the lockring (6), sump (5), and gasket (4) from the filter head.

(d) Remove the hand lever (1) and the packing nut (2) from the shaft of the cartridge disk (7).

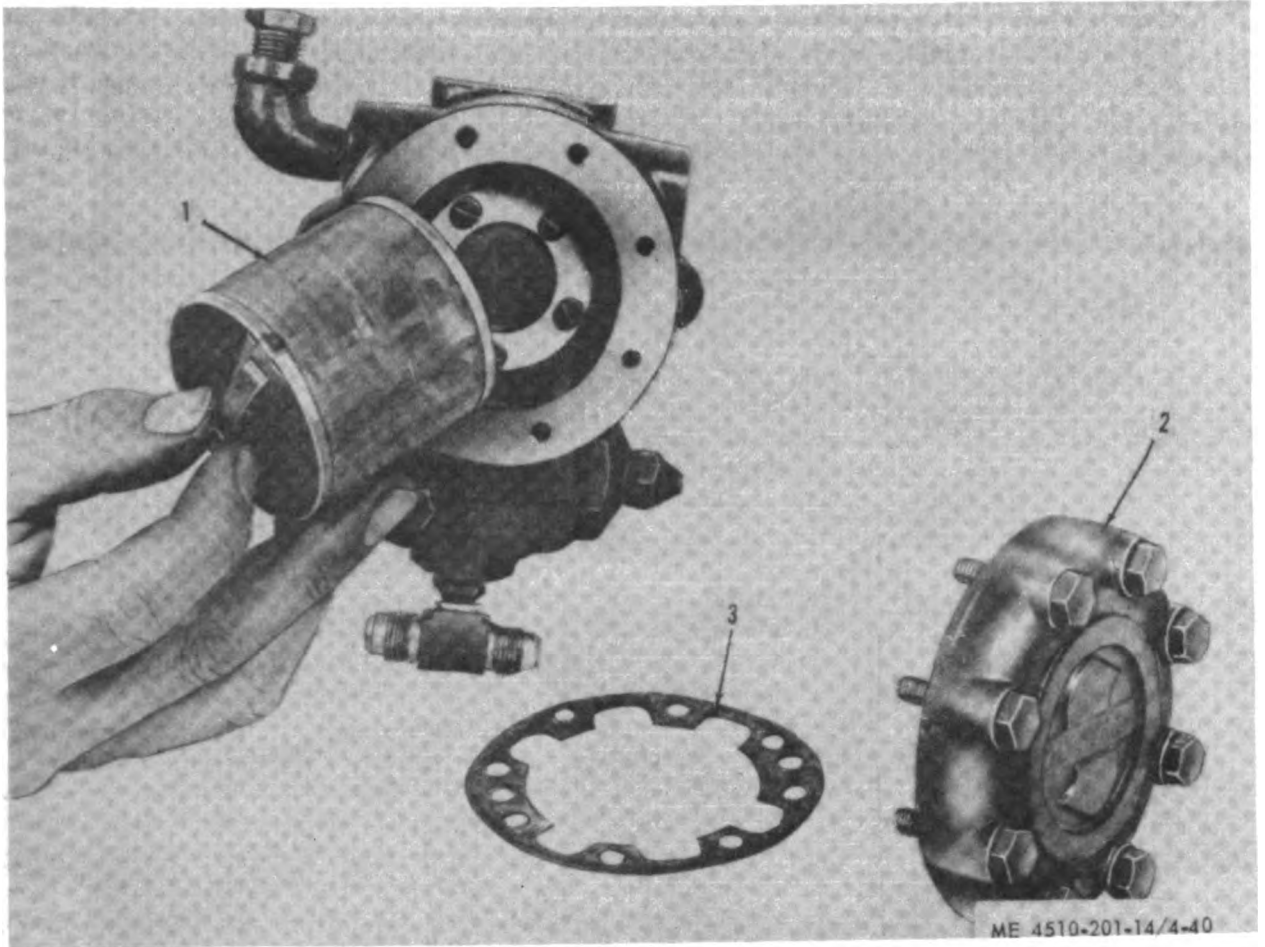
(e) Remove the gland packing from the head.

(4) *Servicing.* Clean all parts with SD (solvent, drycleaning) and dry them thoroughly.

(5) *Inspection.* Inspect for bent sump, for broken or cracked head, and for broken bracket. Inspect the cartridge for damaged fins and inspect the lockring, head, and bracket for damaged threads.

(6) *Installation and Assembly.* Replace defective fuel filter and bracket with serviceable ones. Install the serviceable ones by reversing the procedures in c (2) and c (3) above, using new gland packing and a new gasket in the filter.





- 1 Strainer
- 2 Cover with screws
- 3 Gasket, cover

**Figure 4-40. Fuel pump, strainer removed.**





*d. Fuel Pump Bracket (Used on Army Models SPE 35, SPE 35A, and SPE 41).*

(1) *Removal.*

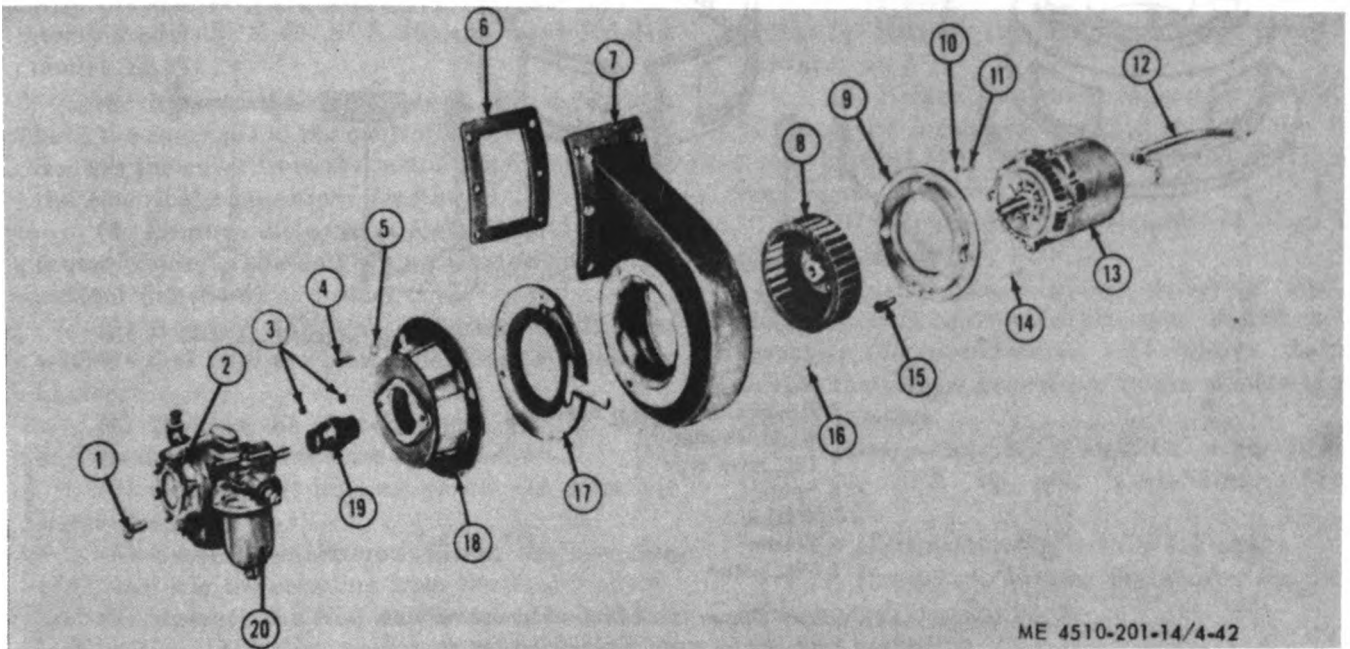
(a) Remove the fuel pump (para a (3) (a) thru (e) above).

(b) Remove the three capscrews (4, fig. 4-42) and the lockwashers (5) that hold the fuel

pump bracket (18) to the blower housing (7), and remove the bracket from the housing.

(2) *Inspection.* Inspect for cracked or broken bracket and damaged threads.

(3) *Installation.* Replace defective bracket with a serviceable one, and install it by reversing the procedure in d (1) above.



- 1 Capscrew
- 2 Pump, fuel
- 3 Setscrews
- 4 Capscrew
- 5 Lockwasher
- 6 Gasket, blower housing-to-water heater
- 7 Housing, blower
- 8 Wheel, blower
- 9 Plate, motor mounting
- 10 Lockwasher

- 11 Capscrew
- 12 Tubing with wires, conduit
- 13 Motor, electric
- 14 Key, blower wheel
- 15 Capscrew
- 16 Setscrew
- 17 Shutter assembly, blower
- 18 Bracket, fuel pump
- 19 Coupling, fuel pump-to-motor shaft
- 20 Filter assembly, fuel

*Figure 4-42. Blower, disassembled.*

*e. Fuel Pump Mounting Bracket With Stop Pin (Used on Army Models SPE 44, SPE 45 and York-Shipley Model YS49279).*

(1) *Removal.*

(a) Remove the fuel pump (para a (3) (a) thru (e) above).

(b) Remove the three capscrews (4, fig. 4-42) and the lockwashers (5) that hold the fuel pump mounting bracket (1, fig. 4-43) to the blower housing (7, fig. 4-42).

**NOTE**

The capscrews, lockwashers, and blower housing as shown in figure 4-42 are the same on all four Army models. The bracket (1, fig. 4-43) used on Army models SPE 44, SPE 45 and York-Shipley

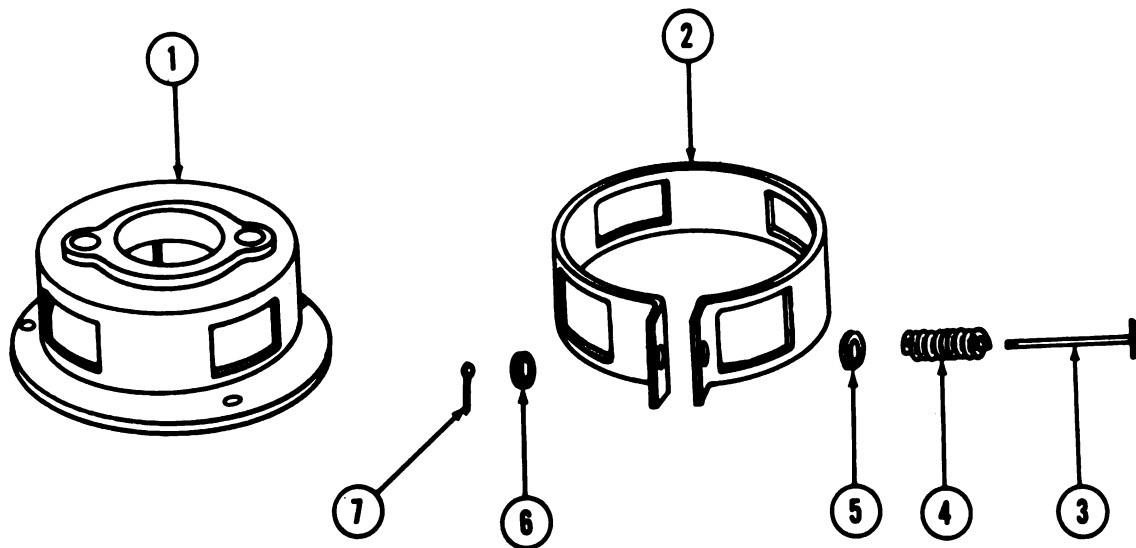
model YS49279, however, differs from the brackets (18, fig. 4-42) used on the other models, in that it is removed with the shutter from the blower housing.

(c) Remove the bracket with the shutter from the blower housing.

(d) Remove the shutter from the bracket (para 4-44 b (3) (a) thru (c)), and free the bracket.

(2) *Inspection.* Inspect for broken or cracked bracket. Inspect the bracket for broken or missing stop pin and for damaged threads.

(3) *Installation.* Replace defective bracket with a serviceable one, and install it by reversing the procedure in e (1) above.



ME 4510-201-14/4-43

- 1 Bracket, fuel pump mounting
- 2 Band, shutter
- 3 Pin, rivet type
- 4 Spring
- 5 Washer
- 6 Washer
- 7 Pin, cotter

Figure 4-43. Blower shutter (used on Army models SPE 44, SPE 45 and York-Shipley model YS49279), disassembled.

#### f. Fuel Pump Coupling.

##### (1) Removal.

(a) Remove the blower shutter assembly (para 4-44 b (3) (a) thru (c)) on Army models SPE 35, SPE 35A, and SPE 41.

(b) Remove the fuel pump mounting bracket with the shutter (para e (1) (a) thru (c) above) on Army Models SPE 44, SPE 45 and York-Shipley Model YS49279.

(c) Remove the setscrews (3, fig. 4-42) in coupling (19), and slip the coupling from the motor shaft.

(2) *Inspection.* Inspect for broken coupling, damaged threads and excessively worn shaft holes.

(3) *Installation.* Replace defective coupling with a serviceable one and install it by reversing the procedure in f (1) above.

#### 4-42. Fuel Fittings and Lines

a. *Servicing.* Clean fuel fittings and line assemblies in SD (solvent, drycleaning) and dry them thoroughly.

b. *Inspection.* Inspect for broken, cracked, and leaking line assemblies, and inspect for stripped or damaged threads on the fittings.

##### c. Removal.

(1) Remove the fuel pump-to-fuel control valve tee line assembly (5, fig. 4-21) from the heater by disconnecting the flared fitting at the side

of the fuel pump. Then loosen the strap holding the line to the bracket, and disconnect the fitting from the control valve tee.

(2) Remove the fuel control valve bypass elbow-to-fuel pump return line assembly (4) from the heater. Disconnect the flared fitting from the tee at the bottom of the fuel pump, loosen the retaining strap that holds the line to the bracket, and disconnect the fittings from the control valve bypass elbow.

(3) Remove the fuel shutoff valve-to-burner nozzle line assembly (fig. 4-19) by disconnecting the flared fitting from the fuel shutoff valve and from the burner nozzle elbow.

(4) Remove the manifold-to-pressure control line assembly by unscrewing the fitting on the upper manifold and unscrewing the fitting at the temperature and pressure control (12, fig. 4-22), and sliding the line assembly from the clips on the water heater.

d. *Installation.* Replace defective fuel line assemblies and fittings with serviceable ones, and install them by reversing the procedures in c above as applicable.

#### 4-43. Blower and Fuel Pump Electric Motor

a. *Description.* The electric motor is mounted on a plate in the lower left front of the water heater.

It furnishes the power to operate the blower and the fuel pump.

*b. Removal.*

(1) Remove the blower shutter assembly (para 4-44 a (3) (a) thru (c)) on Army models SPE 35, SPE 35A, and SPE 41.

(2) Remove the fuel pump mounting bracket with the shutter (para 4-41 e (1) (a) thru (c)) on Army models SPE 44, SPE 45, and York-Shipley model YS49279.

(3) Remove the six screws (1, fig. 4-22) that hold the cover (5) to the control panel box (4), and remove the cover from the box. Disconnect and tag the electrical connections leading to the motor.

(4) Remove the conduit locknut, and slip the motor conduit tube and wiring from inside of the control panel box.

(5) Remove the six capscrews and lockwashers that hold the blower housing to the water heater.

(6) Remove the blower housing (7, fig. 4-42) and the motor (13) from the water heater.

(7) Remove the housing gasket (6) from the water heater.

(8) Loosen the setscrew (3) in the coupling (19), and slip the coupling from the motor shaft.

(9) Remove the four capscrews (11) and the lockwashers (10) that hold the motor mounting plate (9) to the blower housing, and lift the motor off the housing. The blower wheel will be attached to the motor shaft.

(10) Loosen the setscrew (16) in the hub of the blower wheel (8), and slide the blower wheel off the motor shaft. Lift the key (14) from the motor shaft.

(11) Remove the four capscrews (15) that hold the motor to the motor mounting plate, and remove the motor mounting plate.

(12) Disconnect the wiring leads, and remove the conduit tube and the wires from the motor.

*c. Inspection.* Inspect for broken or cracked motor and mounting plate, for damaged shaft threads, and for bent shaft.

*d. Installation.* Replace defective motor and mounting plate with serviceable ones, and install them by reversing the procedure in *b* above. Connect the wires according to the wiring diagram in figure 4-23.

**NOTE**

Be sure to check the rotation of the motor. It should turn in the direction in which the arrow points on top of the fuel pump. Reverse the rotation of the motor by interchanging any two of the external leads at the motor.

**4-44. Blower Shutter Assembly**

*a. Shutter Assembly (Used on Army Models SPE 35, SPE 35A, and SPE 41).*

(1) *Description.* The blower shutter assembly is mounted between the water heater fuel pump bracket and the blower housing. It is used to increase or to decrease the amount of air going to the burner.

(2) *Inspection.* Inspect the shutter assembly for broken segments and stops.

(3) *Removal.*

(a) Remove the fuel pump (para 4-41 a (3) (a) thru (e)).

(b) Remove the three capscrews (4, fig. 4-42) and the lockwashers (5) that hold the fuel pump bracket (18) to the blower housing (7), and remove the bracket.

(c) Lift the shutter assembly (17) off the blower housing.

(4) *Installation.* Replace defective shutter assembly with a serviceable one. Install it by reversing the procedure in *a* (3) above, making certain the shutter lever faces to the outside of the blower housing.

*b. Shutter Assembly (Used on Army Models SPE 44, SPE 45 and York-Shipley Model YS49279).*

(1) *Description.* Refer to *a* (1) above.

(2) *Inspection.* Inspect the shutter for bent, broken, and missing parts.

(3) *Removal.*

(a) Remove the cotter pin (7, fig. 4-43) and the washer (6) from the pin (3).

(b) Remove the pin (3), the spring (4), and the flatwasher (5) from the shutter band (2).

(c) Remove the shutter band from the bracket (1).

(4) *Installation.* Replace defective parts with serviceable ones, and install them by reversing the procedure in *b* (3) above.

**4-45. Blower Assembly**

*a. Blower Housing and Gasket.*

(1) *Removal.* Remove the blower housing (7, fig. 4-42) and the housing gasket (6) from the water heater (paras 4-43 b (1) thru (7)).

(2) *Inspection.* Inspect for cracked or broken blower housing.

(3) *Installation.* Replace defective housing with a serviceable one, and install it by reversing the procedures in *a* (1) above, using a new gasket.

*b. Blower Wheel.*

(1) *Description.* The blower wheel, located in the blower housing, is driven by the blower and fuel pump electric motor. It supplies forced air into the combustion chamber of the water heater.

(2) *Removal.*

(a) Remove the blower wheel and the key from the motor shaft (para 4-43 b (1) thru (10)).

(b) Remove the setscrew (16, fig. 4-42) from the blower wheel.

(3) *Inspection.* Inspect the blower wheel for damaged or broken fins and improper alinement.

(4) *Installation.* Replace defective blower

wheel with a serviceable one, and install it by reversing the procedure in *b* (2) above.

## CHAPTER 5

# DIRECT SUPPORT AND GENERAL SUPPORT MAINTENANCE INSTRUCTIONS

---

### Section I. REPAIR PARTS, SPECIAL TOOLS, AND EQUIPMENT

#### 5-1. Tools and Equipment

Tools, equipment and repair parts issued with or authorized for the bath unit are listed in the Basic Issue Items List, Appendix C.

#### 5-2. Special Tools and Equipment

No special tools or equipment are required by Direct or General Support Maintenance personnel.

#### 5-3. Maintenance Repair Parts

Repair parts and equipment for direct support and general support maintenance for the bath unit are found in TM 10-4510-201-24P.

### Section II. DIRECT AND GENERAL SUPPORT TROUBLESHOOTING

#### 5-4. General

For a general description and purpose of the troubleshooting table, refer to paragraph 3-3.

#### 5-5. Direct and General Support Troubleshooting

Table 5-1 lists the bath unit troubleshooting malfunctions and is as follows:

*Table 5-1. Troubleshooting*

MALFUNCTION	TEST OR INSPECTION	CORRECTIVE ACTION
<b>WATER HEATER ASSEMBLY</b>		
1. WATER TEMPERATURE TOO HIGH OR TOO LOW	Step 1. Check to see if water pressure and temperature control is out of adjustment.	Adjust control (para 6-11).
2. FUEL PUMP NOT FUNCTIONING PROPERLY	Step 1. Check for defective fuel pump.	Install fuel pump repair kit (para 6-12).
3. FUEL PRESSURE ERRATIC	Step 1. Piston in fuel pump defective.	Replace fuel pump with a serviceable one (para 6-12).
4. MOTOR NOISY DURING OPERATION	Step 1. Check for noisy or worn bearings.	Install new bearings (para 6-13).
5. MOTOR DOES NOT OPERATE	Step 1. Check for shorted rotor.	Replace with serviceable motor (para 6-13).
	Step 2. Check for open or shorted windings.	Replace with serviceable motor (para 6-13)

### Section III. GENERAL MAINTENANCE INSTRUCTIONS

#### 5-6. General

a. This section provides general cleaning, inspection and repair instructions that are common to components used on the bath unit.

b. Special cleaning, inspection and repair instructions applicable to any individual component are covered with that component in the applicable sections of this manual.

## 5-7. General Cleaning Instructions

### a. Metal Parts.

(1) Prior to removal or disassembly of components, clean off excess oil or dirt with a cleaning solvent (Fed Spec P-D-680) or steam clean.

(2) Use a cleaning solvent (Fed Spec P-D-680) to clean parts such as housings and hand-packed bearings.

### CAUTION

Do not immerse oil impregnated bearings or sealed bearings in cleaning solvent. Clean with a solvent-moistened cloth.

(3) Use brushes to clean irregular shaped surfaces. Use wooden pegs to clean ports and orifices. Use a lint-free cloth to wipe parts clean.

(4) Exercise care when handling machined and polished surfaces to avoid nicks and other damage. Do not immerse more than one metal machined port in solvent at the same time, unless such parts are separated or protected from contacting each other.

### b. Electrical Components.

(1) Prior to removal or disassembly of electrical components, clean exterior by scraping off excess oil and dirt. Wipe clean with a lint-free cloth dampened with cleaning solvent (Fed Spec P-D-680).

### CAUTION

Do not immerse any electrical component or device in cleaning solvent.

(2) Clean armatures, coils and solenoids with compressed air and wipe clean with a lint-free cloth dampened in cleaning solvent.

### CAUTION

Safety glasses must be used when cleaning parts with compressed air.

(3) Wipe electrical terminals clean with a lint-free cloth dampened with cleaning solvent. Use a soldering iron to clean solder from terminals and connectors.

### c. Gaskets, Seals and O-Rings.

(1) Clean all old gasket particles from mating surfaces.

(2) Discard and replace all gaskets, seals, O-rings and flat washers.

## 5-8. General Inspection Instructions

a. *General.* Perform an inspection of all parts as soon as possible after cleaning. Instructions for specific inspection procedures are included throughout the manual for each specific component.

b. *Visual Inspection.* Visually inspect all machined and polished areas. Use a strong light to shine across polished surfaces to inspect for scoring, cracks, breaks or excessive wear.

### c. Electrical Parts.

(1) Visually inspect wiring for frayed edges or damaged insulation.

(2) Inspect all electrical parts such as solenoids, with power applied, to observe actual operation.

## 5-9. General Repair Instructions

a. *Thread Repair.* Use the proper size tapping tool to repair tapped holes. Discard and replace all hardware that has defective threads.

### b. Press Fit Parts.

(1) Bearings may require the use of a pneumatic or hand-operated arbor press.

(2) Preheat all press-fit parts before reassembly if specified. If necessary, use a lubricant to reduce abrasive action.

### CAUTION

Do not press on the outer race of bearings when installing on shafts.

## CHAPTER 6

# REPAIR OF MISCELLANEOUS ITEMS, SHOWER STAND AND PUMP ASSEMBLY, AND WATER HEATER ASSEMBLY

---

### Section I. MISCELLANEOUS ITEMS

#### 6-1. General

This section describes the direct support maintenance requirements for the bath unit baseboard.

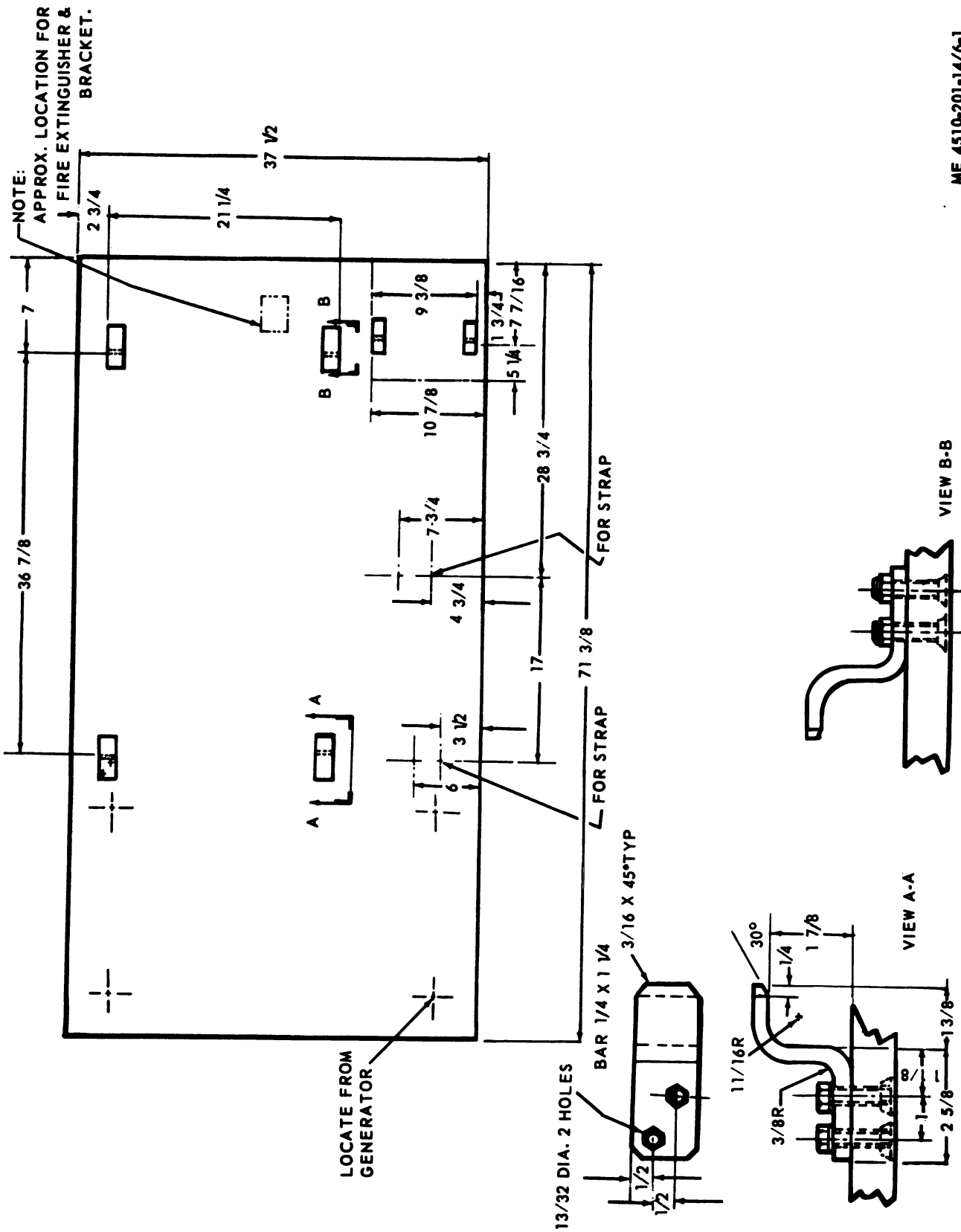
#### 6-2. Baseboard

The baseboard is used to support and to carry the entire bath unit during transit.

*a. Inspection, Cleaning, Removal, and Installation.* Refer to procedures in paragraph 4-17.

*b. Repair.* Fabricate a new or unserviceable baseboard by referring to figure 6-1 and by cutting a bulk piece of  $\frac{3}{4}$  inch exterior plywood  $37\frac{1}{2}$  by  $71\frac{1}{2}$  inches. Using the defective baseboard as a pattern, mark and drill holes in the new baseboard. Paint the baseboard according to the instructions in TM 9-213.





ME 4510-201-14/6-1

Figure 6-1. Fabrication details for baseboard.

## Section II. SHOWER STAND AND PUMP ASSEMBLY

### 6-3. General

This section describes the direct support maintenance requirements for the shower stand riser, the water pump assembly frame, and the electrical conduit.

### 6-4. Shower Stand Riser

The shower stand riser is used to support the shower stand head and legs when the stand is set up for operation.

*a. Removal, Inspection and Installation.* Refer to procedures in paragraph 4-20.

*b. Repair.* Straighten and weld broken leg inserts and broken soap tray. Use a pipe die to repair damaged threads.

### 6-5. Water Pump Frame

*a. Inspection, Removal and Installation.* Refer to paragraph 4-24.

*b. Repair.* Straighten bends and weld all cracks and breaks in the pump frame.

### 6-6. Electrical Conduit

Fabricate a water pump motor conduit tube 12¼ inches long from the bulk metal conduit (½ in. by 10 ft) to replace a defective water pump motor conduit tube. This tube is fabricated by the direct support maintenance personnel to be used by organizational personnel to replace a defective tube.

## Section III. WATER HEATER ASSEMBLY

### 6-7. General

This section describes the direct support and general support maintenance instructions for the water heater components which include the pressure and temperature control, handles, skid, tank, fuel pump, conduit, and transformer.

### 6-8. Ignition Transformer

*a. Removal and Installation.* Refer to paragraph 4-30.

*b. Test.* Use an ohmmeter to test the transformer for defective wiring. Make the continuity and ground tests according to the following procedures:

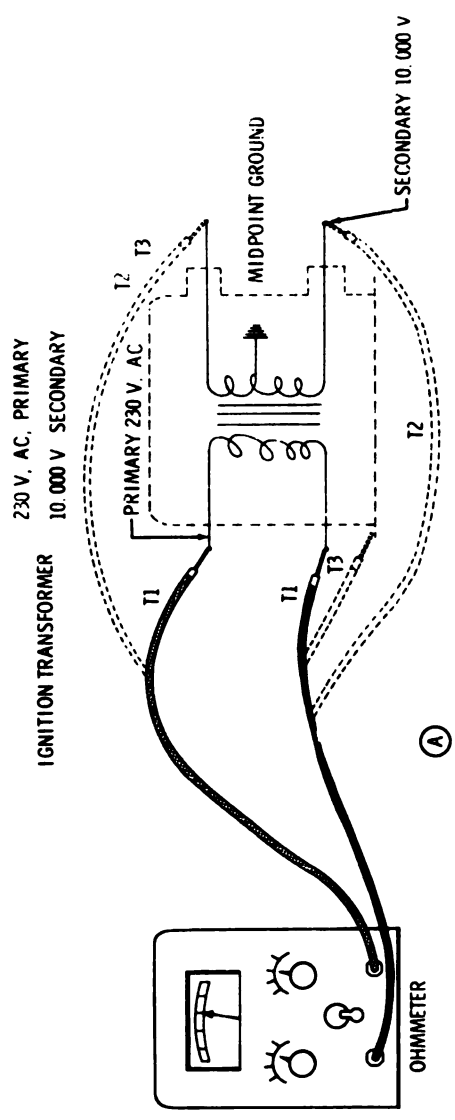
(1) *Continuity tests.* Check the winding for continuity by performing the tests (T1, T2, and

T3) as indicates on figure 6-2A. If the meter indicates an infinite resistance (needle stays at extreme limit of maximum resistance), the winding is open circuited. If the meter indicates zero resistance, the winding is short circuited. If the winding is in good condition, the meter reading should correspond to the resistance value of the winding specified in figure 6-2A.

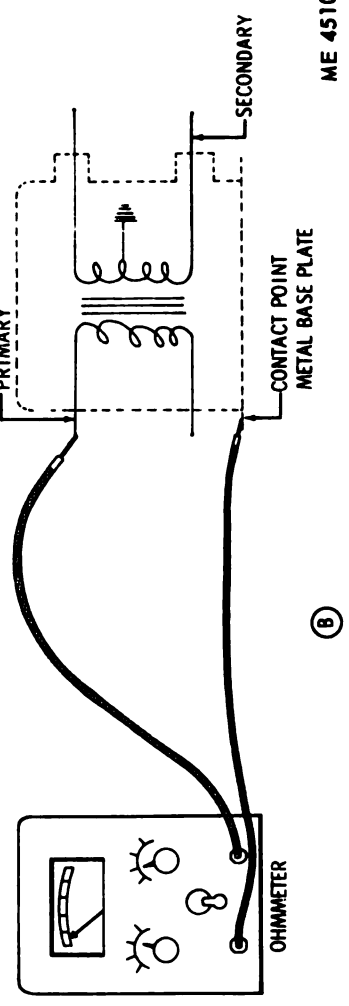
(2) *Ground test.* Test the primary winding for a possible ground by connecting the meter between the transformer core and one of the windings as indicated in figure 6-2B. An infinite resistance reading means that the winding is not grounded and zero resistance means that the winding is grounded at some point near the terminal where one of the test leads is connected.

**CONTINUITY TESTS**

- T1** READING SHOULD BE APPROXIMATELY 7 OHMS BETWEEN PRIMARY TERMINALS.
- T2** READING SHOULD BE APPROXIMATELY 20,000 OHMS OR 20K ACROSS SECONDARY TERMINALS.
- T3** READING SHOULD BE APPROXIMATELY 10,000 OHMS OR 10K BETWEEN IRON CORE AND ONE SECONDARY TERMINAL.



**GROUND TEST**



ME 4510-201-14/6-2

Figure 6-2. Schematic drawing of test procedures for transformer.

## 6-9. Skid and Bail Handle

### a. Description.

(1) *Skid*. The skid is used to support the water heater during operation and transit.

(2) *Bail handle*. There are four bail handles attached in welded brackets on the water heater. Two handles are located on the front, and two handles are located on the rear. The handles are used to lift and move the water heater.

### b. Inspection.

(1) *Skid*. Refer to paragraph 4-31.

(2) *Bail handle*. Inspect for bent, broken and missing handle.

### c. Removal.

(1) *Skid*. Refer to paragraph 4-31.

(2) *Bail handle*. Heat the handle and bend it until the ends of it will clear, and come out the holes in the welded bracket.

### d. Repair and Installation.

(1) *Skid*. Straighten all bends. Weld all cracks and breaks to include welding reinforcement pipes to the mounting plates, and welding the mounting plates to the skid. Make certain that repairs made to the skid do not change the alignment of the holes for mounting the heater and assemblies.

(2) *Bail handles*. Replace defective handle with a serviceable one. Heat the handle, and bend it until the ends will go in the holes in the bracket. Heat the handle again, and bend it in the shape of a handle.

## 6-10. Welded Tank

a. *Inspection*. Refer to paragraph 4-38.

### b. Removal.

(1) Refer to section VII of chapter 4 and remove the water blender valve, shower stand control valve, relief valve, burner assembly, blower, and all other attaching parts from the tank.

(2) Remove the nuts, lockwashers, and capscrews that secure the tank to the skid, and remove the tank from the skid.

c. *Repair*. Straighten bends. Weld broken or

damaged piping, supports, shell, firebox, and bail handle brackets. Make certain the upper and lower manifold piping is completely welded to the tank. Be sure all weld spots on the tank are smooth and complete.

d. *Installation*. Replace a defective tank with a serviceable one and install it by reversing the procedures in *b* above.

## 6-11. Pressure and Temperature Control

The pressure and temperature control is located beside the control panel box on the water heater. It is an automatic safety control. It prevents the burner from being fired until water is in the heater and it prevents water that is above 120°F., from being supplied to the shower head nozzles. When the pressure of the incoming water reaches 10 pounds per square inch, the pressure contacts in the pressure and temperature control close. This action causes the solenoid valve to open and, thereby, allows fuel to be supplied to the burner. When, during operation, the water temperature exceeds 120°F., the contacts open. This action causes the solenoid valve to close, and thereby stops the flow of fuel to the burner.

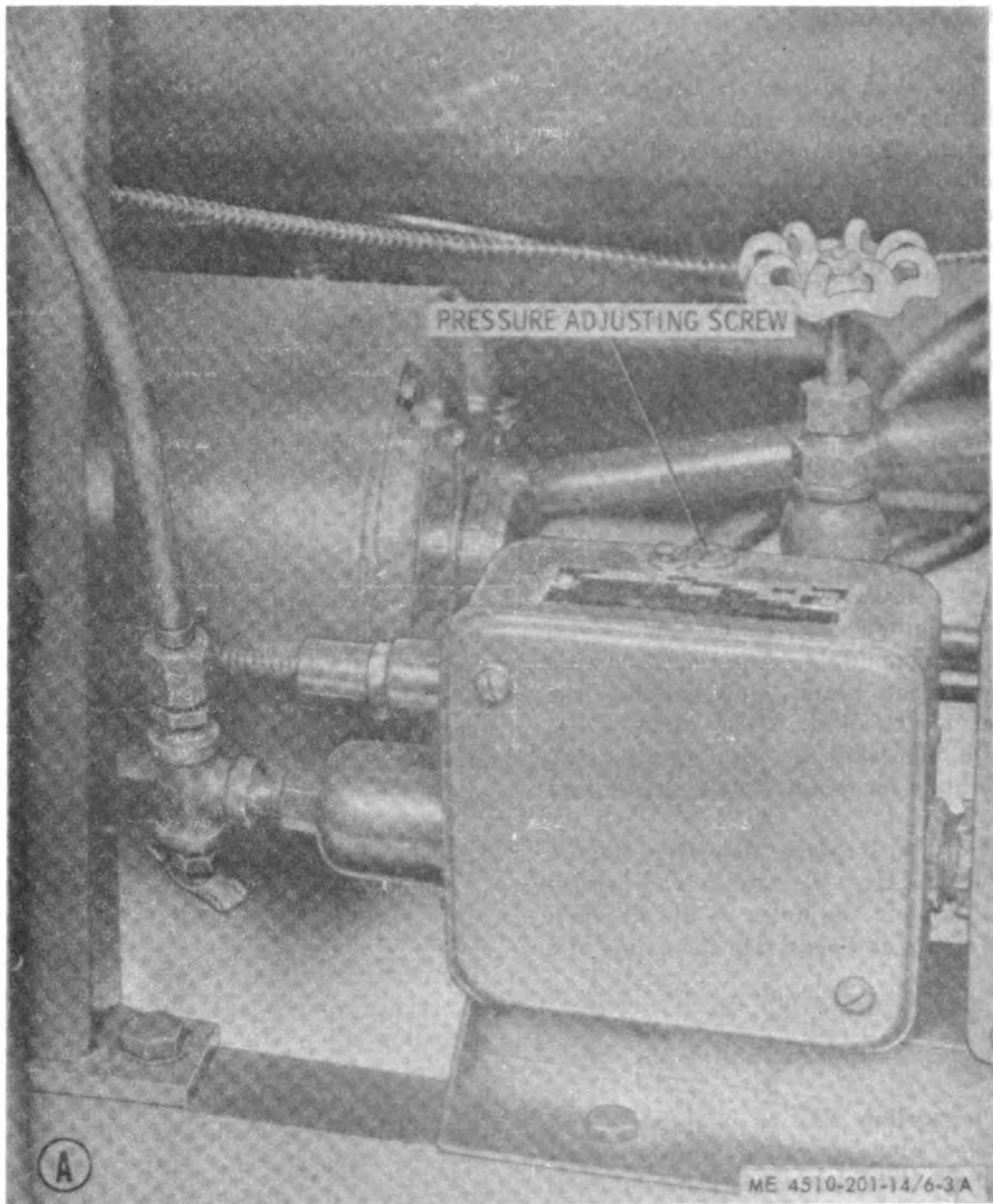
### NOTE

The water heater must be in operation to adjust the pressure and temperature control.

a. *Control Adjustment (Used on Army Models SPE 35, SPE 35A, SPE 41, SPE 44 and York-Shipley Model YS49279)*.

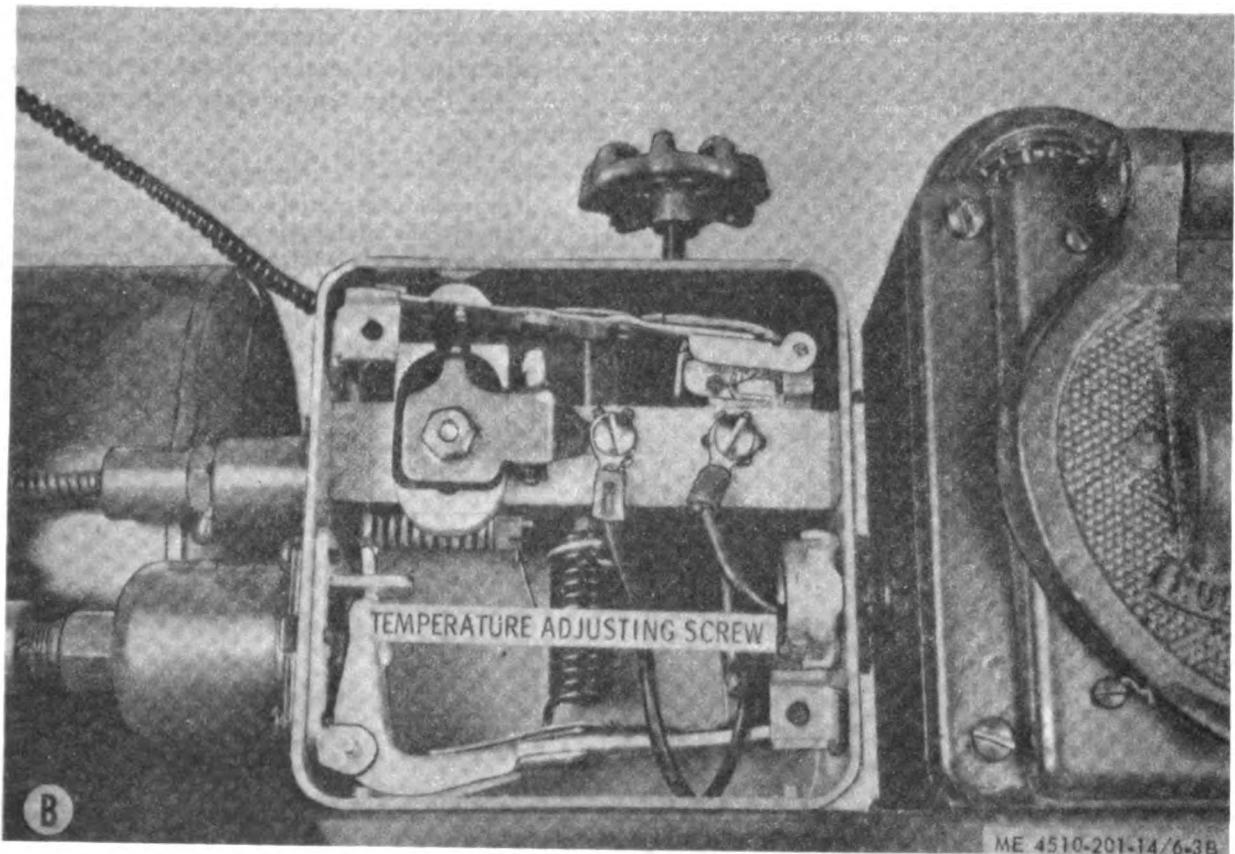
(1) *Pressure adjustment*. Turn the pressure adjusting screw (fig. 6-3A) located on top of the control, clockwise to increase the pressure to 10 pounds per square inch. Turn the adjusting screw counterclockwise to decrease the pressure.

(2) *Temperature adjustment*. Remove the cover from the pressure and temperature control. Turn the temperature adjusting screw (fig. 6-3B) clockwise to a desired point to increase the temperature and counterclockwise to a desired point to decrease the temperature.



A. Pressure adjusting screw.

**Figure 6-3. Pressure and temperature control (Used on all Army models except SPE 45) (sheet 1 of 2).**



B. Temperature adjusting screw.

Figure 6-3. Pressure and temperature control (Used on all Army models except SPE 45) (sheet 2 of 2).

b. Control Adjustment (used on Army Model SPE 45).

**NOTE**

This adjustment applies to all models upon control changeover using part numbers YS-4482, YS-147901, or YS-147902.

(1) Temperature control adjustment.

(a) Remove cover from pressure-temperature control.

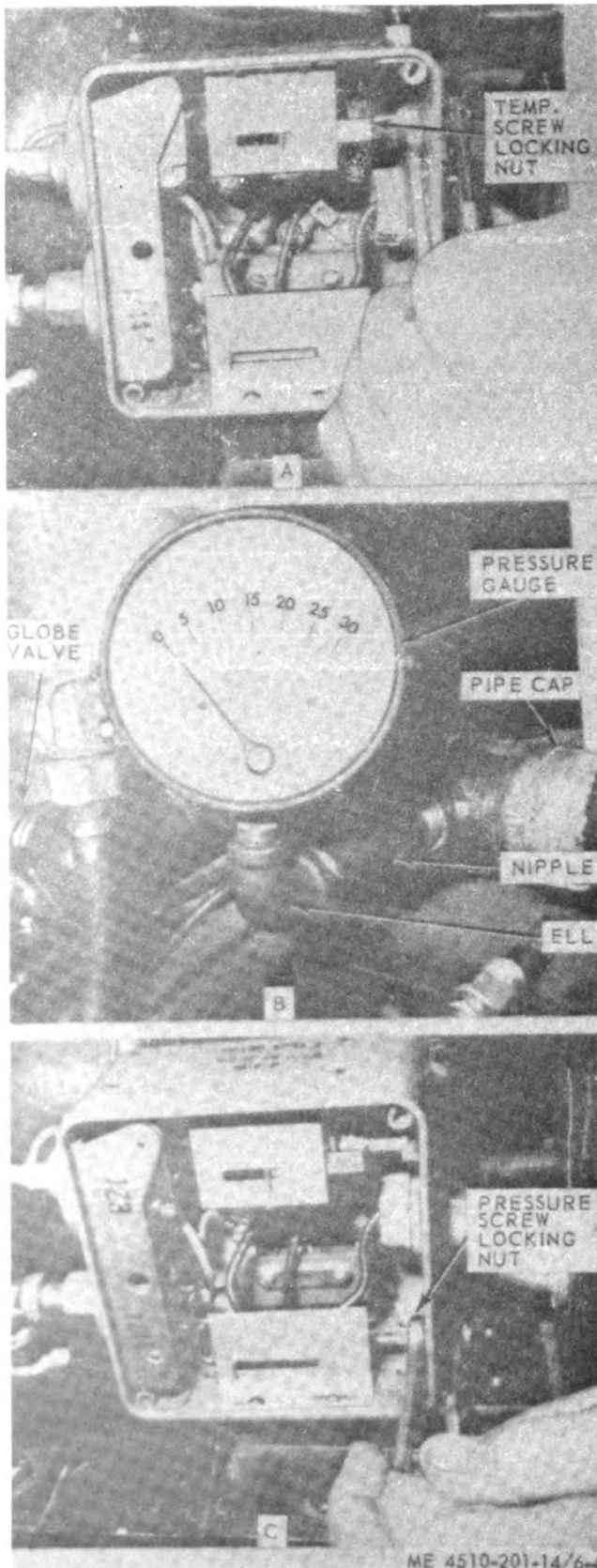
(b) Loosen hex nut that locks the temperature adjusting screw at the top, right side of the controller case (fig. 6-4A).

(c) Adjust temperature adjusting screw counterclockwise to increase cut-out temperature, and clockwise to decrease cutout temperature.

(d) Tighten temperature adjustment screw locking nut.

**NOTE**

The temperature control is affected by a change in altitude. The information in figure 6-5 should be used as a guide in making temperature corrections for altitude changes. The corrections should be performed as in b (1) above.



- A. Temperature adjusting screw
- B. Pressure gauge installation
- C. Pressure adjusting screw

**Figure 6-4. Pressure and temperature control (Used on Army Model SPE 45).**

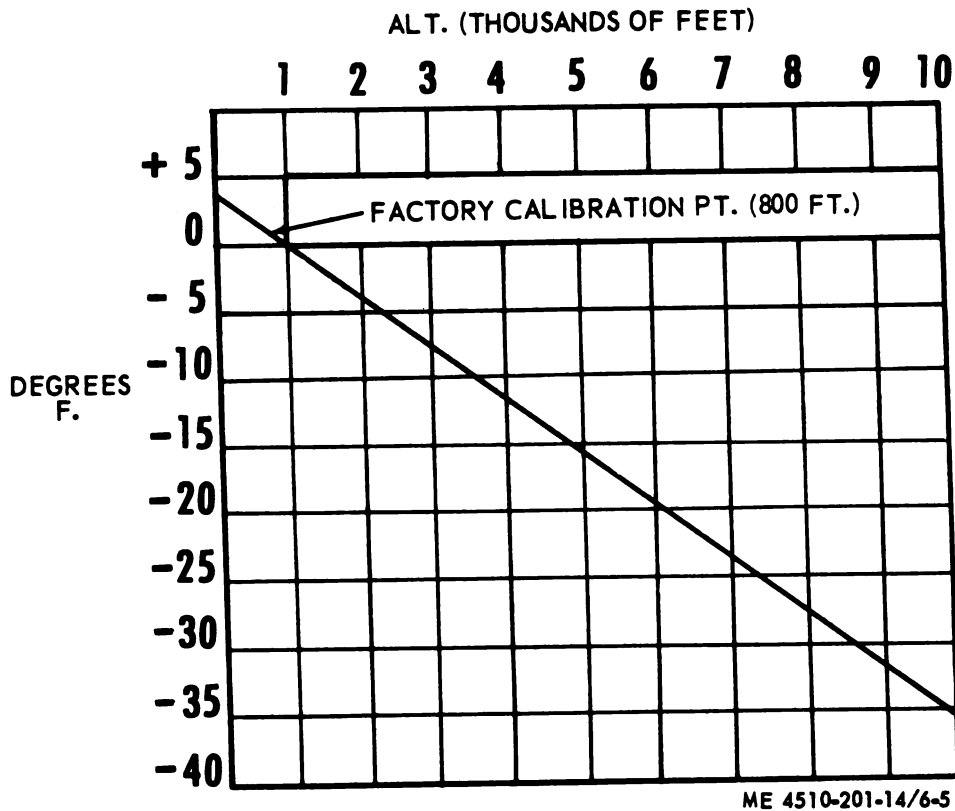


Figure 6-5. Altitude variations graph.

(2) *Pressure setting adjustment.*

**NOTE**

The water pressure control is set to energize the fuel solenoid valve at 10-15 P.S.I.G. water pressure, and deenergize the fuel solenoid valve at 6 P.S.I.G. pressure.

- (a) Remove hose quick connector from water header and close off end of header with 1½ inch I.P.S. pipe cap (fig. 6-4B).
- (b) Remove temperature bulb from header and install ½ inch pipe nipple, reducing ell and pressure gauge (fig. 6-4B).
- (c) Install hose to quick connector at outlet of globe valve (fig. 6-4B) and allow hose to lay on ground.
- (d) With 1½ inch globe valve fully open, turn on water supply.
- (e) Turn fuel pump motor switch on.
- (f) Slowly close 1½ inch globe valve in water header and observe pressure gauge when pressure control energizes fuel solenoid valve.
- (g) Slowly open globe valve and observe pressure gauge reading when fuel solenoid valve is de-energized.
- (h) To make pressure adjustments, remove cover from pressure-temperature control.
- (i) Loosen hex nut that locks the pressure adjusting screw at the bottom right side of the controller case (fig. 6-4C).

(j) Pressure adjustment is made by turning adjusting screw clockwise to increase cutout pressure and counterclockwise to decrease cutout pressure, using an offset screw driver.

(k) After each change in the pressure adjusting screw steps (f) and (g) should be repeated. Pressure adjusting screw locking nut should be tightened after each change in adjustment screw.

(l) After correct pressure setting is obtained (fuel solenoid valve energized at 10 to 15 P.S.I.G.), remove pressure gauge, elbow and ¾ inch nipple. Reinstall temperature bulb and tighten compression fitting. Remove 1½ inch pipe cap, and reinstall hose quick connector.

**6-12. Fuel Pump Assembly**

The fuel pump, located on the lower left end of the water heater, draws fuel from the fuel drum and forces it to the burner.

- a. *Removal.* Refer to paragraph 4-41 and remove the fuel pump from the water heater.
- b. *Disassembly.*

- (1) Remove the eight cover screws (1, fig. 6-6) that secure the cover (2) to the pump body (14), and remove the cover and the gasket (3) from the fuel pump body.
- (2) Remove the strainer (4) from the body.
- (3) Remove the five end plate screws (5) from



the end plate (6), and remove the end plate and the gear set (7) from the body.

(4) Use snapping pliers to remove the seal retaining ring (20) from the large seal O-ring (19), and then press the drive shaft assembly (15) out of the body.

(5) Remove the stationary seal face (18) and the seal assembly (17) from the shaft assembly.

(6) Remove the large seal O-ring (19) from the face (18), and remove the small seal O-ring (16) from the seal assembly.

(7) Remove the end capnut (21) and the gasket (22) from the screw assembly (23).

(8) Remove the screw assembly and the gasket (24) from the body.

(9) Remove the pressure regulating spring seat (25) and the pressure regulating spring (26) from the piston assembly (27).

(10) Remove the piston assembly from the piston sleeve (13) inside the body.

(11) Remove the end plug assembly (10) and the gasket (11) from the body.

(12) Remove the piston sleeve from the body, and remove the O-ring (12) from the piston sleeve.

(13) Press the port housing (8) from the body, and remove the port housing gasket (9) from the body.

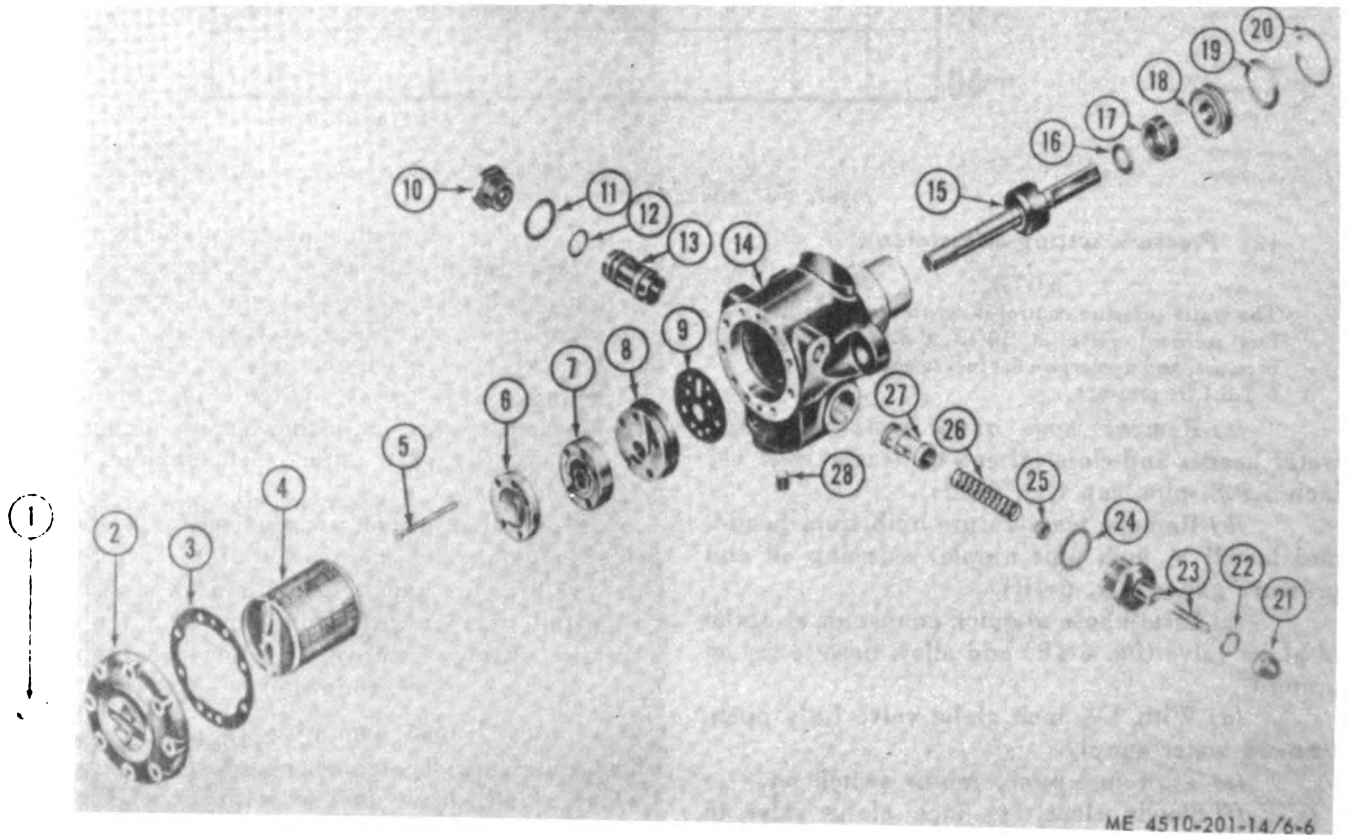
(14) Remove the bypass plug (28) from the body.

*c. Servicing.* Clean all parts in SD (solvent, drycleaning) and dry them thoroughly.

*d. Inspection.* Inspect for burred, nicked, broken, scratched, and excessively worn parts.

*e. Repair and Assembly.* Replace defective parts, using serviceable ones supplied in the repair kit, and install them by reversing the procedures in *b* above

*f. Installation and Adjustment.* Refer to the procedures in paragraph 4-41.



- |                    |                                    |                               |  |
|--------------------|------------------------------------|-------------------------------|--|
| 1 Screw, cover     | 8 Housing, port                    | 15 Shaft assembly, drive      | 22 Gasket, end capnut                  |
| 2 Cover            | 9 Gasket, port housing             | 16 O-ring, small seal         | 23 Screw assembly, pressure regulating |
| 3 Gasket, cover    | 10 Plug assembly, end              | 17 Seal assembly, drive shaft | 24 Gasket, end cap and plug            |
| 4 Strainer, fuel   | 11 Gasket, end cap and plug        | 18 Face, stationary seal      | 25 Seat, pressure regulating spring    |
| 5 Screw, end plate | 12 O-ring, piston sleeve retaining | 19 O-ring, large seal         | 26 Spring, pressure regulating         |
| 6 Plate, end       | 13 Sleeve, piston                  | 20 Ring, seal retaining       | 27 Piston assembly                     |
| 7 Set, gear        | 14 Body, pump                      | 21 Capnut, end                | 28 Plugs, bypass                       |

Figure 6-6. Fuel pump, disassembled.

### 6-13. Blower and Fuel Pump Electric Motor

*a. Description.* This paragraph describes the general support maintenance instructions for the water heater blower and fuel pump electric motor. The motor, located in the lower, left front of the water heater, furnishes the power to operate the blower and the fuel pump.

*b. Removal.* Refer to the procedures in paragraph 4-43.

*c. Disassembly.*

#### NOTE

Before disassembling the motor, mark the end plates and the housing for proper assembling.

(1) Remove the thru-bolts (11, fig. 6-7) that hold the end plates (1 and 10) to the housing (8).

(2) Remove the end plates from the housing.

(3) Slide the rotor (5) from the housing.

(4) Remove the bearings (3 and 7) and the seats (4 and 6) from the rotor.

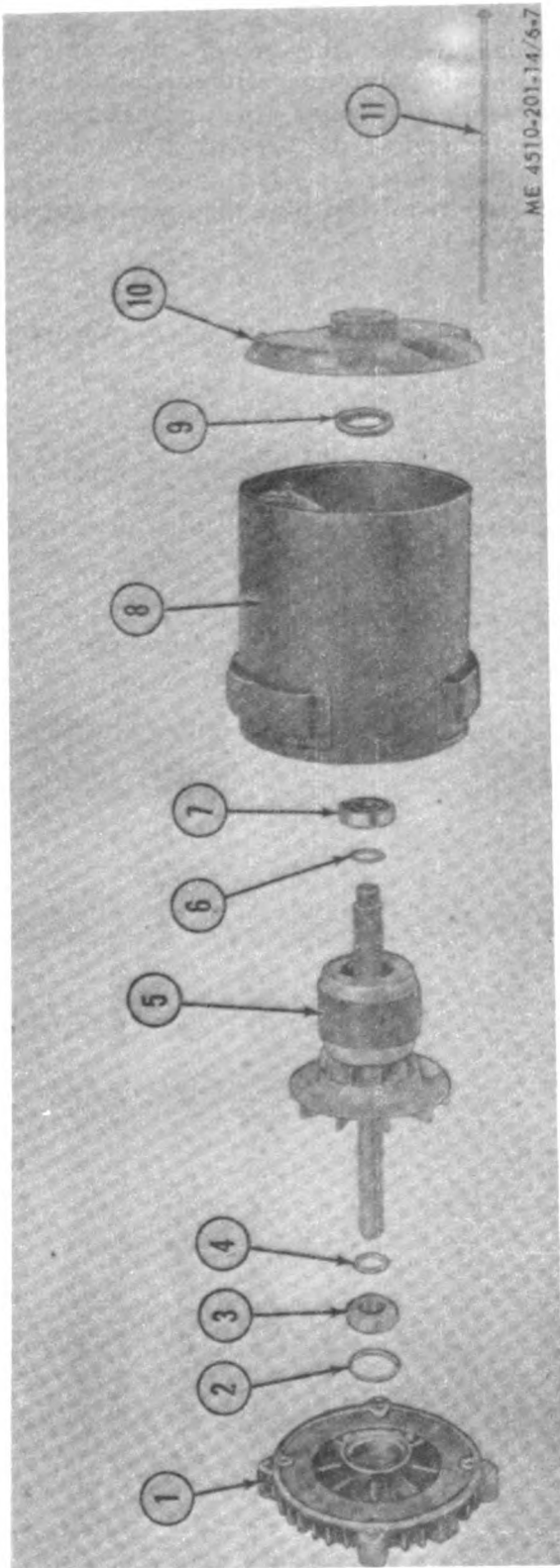
*d. Service.* Wipe all parts with a clean, dry cloth.

*e. Inspection.* Inspect for burned rotor, bent fins, damaged shaft, and rough or excessively worn bearings.

*f. Repair.* Repair the motor by replacing defective bearings and rotor with serviceable ones.

*g. Assembly.* Reverse the procedures in *c* above, lubricating the bearings before placing them on the rotor.

*h. Installation.* Refer to the procedures in paragraph 4-43.



- 1 Plate, end
- 2 Shims
- 3 Bearing, ball
- 4 Seat, bearing
- 5 Rotor
- 6 Seat, bearing
- 7 Bearing, ball
- 8 Housing
- 9 Shims
- 10 Plate, end
- 11 Thru-bolt

Figure 6-7. Water heater blower and fuel pump motor, disassembled.

**6-14. Electrical Conduit**

**Fabricate a blower motor conduit tube  $12\frac{1}{4}$  inches long and fabricate a transformer conduit tube  $19\frac{1}{2}$  inches long from the bulk metal conduit ( $\frac{1}{2}$  in. by**

**10 ft). These tubes are fabricated by the direct support maintenance personnel but they are used by the organizational personnel to replace defective tubes.**



## CHAPTER 7

### ADMINISTRATIVE STORAGE

#### 7-1. Preparation of Equipment for Storage

*a. Limited Storage.* Detailed instructions for the preparation of the bath unit for limited storage are discussed within this paragraph as follows:

**NOTE**

Limited storage is defined as storage not to exceed six months.

(1) *Inspecting.* Inspect the bath unit for conditions such as dirt, oil, corroded spots, missing items, and damages of any nature. Perform the inspection procedures relative to the individual components and assemblies as outlined in the preventive maintenance services, in paragraph 3-1 and table 3-1.

(2) *Draining and dismantling.* Drain the water from the heater, water pump, and hoses (para 2-3 *a*). Drain the fuel from the filter, and put oil in the pump according to the procedures in paragraph 2-12 *g*. Refer to the procedures in paragraph 2-3 *b* for dismantling the bath unit.

(3) *Lubricating.* Lubricate the generator set in accordance with the instructions in the applicable technical manual listed in Appendix A.

(4) *Cleaning and drying.* Remove all contamination from the components of the bath unit by an approved method. Approved methods of cleaning and drying, the types of preservatives to be used, and the methods of applying the preservatives are described in TM 38-230.

(5) *Seal openings.* Seal the end of all hose assemblies and all openings on the heater, the water pump, and the generator with pressure-sensitive tape, which conforms to Specification PPP-T-60, Type III, Class I.

(6) *Placing on baseboards.* Place the bath unit on the baseboard by reversing the procedures in paragraph 2-2 *b* and as shown in figure 4-1.

**NOTE**

It is not necessary to crate the bath unit for storage not to exceed six months.

*b. Regular Storage.*

**NOTE**

Regular storage is defined as storage which is longer than six months.

(1) *General.* Detailed instructions for the preparation of the bath unit for regular storage are outlined in this paragraph. Preservation will be accomplished in a sequence that will not require the operation of previously preserved components. In addition to the instructions for preparation of the

bath unit for shipment given in *a* above, perform the following:

(2) *Inspection.* Before the bath unit is to be stored, it must be inspected thoroughly to be sure it is in a serviceable condition. Perform the preventive maintenance services (paras 4-9 and 4-10) to be sure the bath unit operates satisfactorily. Correct all deficiencies if the facilities are available for such services.

(3) *Cleaning and drying.* All contamination shall be removed from the bath unit by an approved method. Approved methods of cleaning, drying, types of preservatives, and methods of application are described in TM 38-230.

(4) *Painting.* Repaint all surfaces where the paint has been damaged or removed. Refer to TM 9-213 for detailed painting instructions. Apply a medium-grade protective lubricating oil to exposed, polished, or ground metal surfaces susceptible to corrosion and not otherwise protected.

(5) *Packing.* Pack or place the bath unit on the baseboard according to the procedures set forth in *a* (6) above. Seal with pressure-sensitive tape, and then spray with a preservative compound all openings on the water heater, water pump, hoses, shower stands, and generator set. Wrap the suction hose strainer, generator outlet box, and all repair parts and tools in barrier material and then seal them.

(6) *Crating.*

(*a*) Place the baseboard with packed bath unit on the bottom frame of the packing crate, and install the nuts securing the baseboard to the bottom frame of the crate as shown in figure 4-1.

(*b*) Place the sides to the bottom frame of the crate, installing the lag screws to secure the sides to the bottom.

(*c*) Place the top on the sides of the crate and install the lag screws to secure the sides.

(7) *Placing unit in storage.* Store the bath unit in a shelter if possible, and cover it with a tarpaulin. The bath unit should be free of dust and moisture, and easily accessible for inspection and maintenance. If it is impossible to store the bath unit in a shelter, select a firm, level, well-drained storage location, protected from prevailing winds to store the bath unit. Position the bath unit (packed on baseboard) on heavy planking. Cover the bath unit with a tarpaulin or other suitable waterproof covering, and secure it in a manner that will

provide the bath unit maximum protection from the weather elements.

**7-2. Inspection and Maintenance of Equipment in Storage**

During storage, inspect the bath unit every 90 days as outlined in the quarterly preventive maintenance services (para 4-9 and 4-10) and operate it long

enough to assure proper functioning of the generator set, water heater, water pump, and shower stands, including all controls and instruments. Be sure there are no leaking hoses and fuel lines. After each inspection period, prepare the bath unit as outlined in paragraph 7-1 b (3) thru (5).

# APPENDIX A

## REFERENCES

---

### A-1. Fire Protection

TB 5-4200-200-10

Hand Portable Fire Extinguishers for Army Users

### A-2. Painting

TM 9-213

Painting Instructions for Field Use

### A-3. Maintenance

TM 5-764

TM 10-4510-201-24P

Electric Motor and Generator Repair

Organizational, Direct and General Support Repair Parts and Special Tools Lists (Includes Depot Maintenance Repair Parts)

TM 5-6115-271-14

Operator, Organizational, Direct Support and General Support Maintenance Manual

TM 5-6115-271-20P / 35P

Organizational (P-Manual) and DS, GS and Depot (P-Manual) Maintenance Repair Parts and Special Tools List

TM 9-237

Welding: Theory and Application

TM 38-750

The Army Maintenance Management System

### A-4. Shipment and Storage

TB 740-93-2

Preservation of USAMEC Mechanical Equipment for Shipment and Storage

TM 38-230

Preservation, Packaging, and Packing of Military Supplies and Equipment

TM 740-90-1

Administrative Storage of Equipment

SB 38-100

Preservation, Packaging, and Packing Materials, Supplies and Equipment Used by the Army

### A-5. Destruction to Prevent Enemy Use

TM 750-244-3

Procedures for Destruction of Equipment to Prevent Enemy Use (Mobility Equipment Command)

### A-6. Health Care

TB MED 167

Schistosomiasis





# APPENDIX B

## MAINTENANCE ALLOCATION CHART

### Section I. INTRODUCTION

#### B-1. General

a. This section provides a general explanation of all maintenance and repair functions authorized at various maintenance levels.

b. Section II designates overall responsibility for the performance of maintenance functions on the identified end item or component. The implementation of the maintenance functions upon the end item or component will be consistent with the assigned maintenance functions.

c. Section III—Not applicable.

d. Section IV—Not applicable.

#### B-2. Explanation of Columns in Section II

a. *Group Number, Column (1).* The assembly group number is a numerical group assigned to each assembly. The assembly groups are listed on the MAC in disassembly sequence beginning with the first assembly removed in a top down disassembly sequence.

b. *Assembly Group, Column (2).* This column contains a brief description of the components of each assembly group.

c. *Maintenance Functions, Column (3).* This column lists the various maintenance functions (A through K). The upper case letter placed in the appropriate column indicates the lowest maintenance level authorized to perform these functions. The symbol designations for the various maintenance levels are as follows:

- C—Operator or crew
- O—Organizational maintenance
- F—Direct support maintenance
- H—General support maintenance

The maintenance functions are defined as follows:

A—Inspect. To determine serviceability of an item by comparing its physical, mechanical, and electrical characteristics with established standards.

B—Test. To verify serviceability and to detect electrical or mechanical failure by use of test equipment.

C—Service. To clean, to preserve, to charge, and to add fuel, lubricants, cooling agents, and air. (If it is desired that elements, such as painting and lubricating, be defined separately, they may be so listed.)

D—Adjust. To rectify to the extent necessary to bring into proper operating range.

E—Align. To adjust specified variable elements of an item to bring to optimum performance.

F—Calibrate. To determine the corrections to be made in the readings of instruments or test equipment used in precise measurement. Consists of the comparison of two instruments, one of which is a certified standard of known accuracy, to detect and adjust any discrepancy in the accuracy of the instrument being compared with the certified standard.

G—Install. To set up for use in an operational environment such as an emplacement, site, or vehicle.

H—Replace. To replace unserviceable items with serviceable like items.

I—Repair. Those maintenance operations necessary to restore an item to serviceable condition through correction of material damage or a specific failure. Repair may be accomplished at each level of maintenance.

J—Overhaul. Normally, the highest degree of maintenance performed by the Army in order to minimize time work is in process consistent with quality and economy of operation. It consists of that maintenance necessary to restore an item to completely serviceable condition as prescribed by maintenance standards in technical publications for each item of equipment. Overhaul normally does not return an item to like new, zero mileage, or zero hour condition.

K—Rebuild. The highest degree of materiel maintenance. It consists of restoring equipment as nearly as possible to new condition in accordance with original manufacturing standards. Rebuild is performed only when required by operational considerations or other paramount factors and then only at the depot maintenance level. Rebuild reduces to zero the hours or miles the equipment, or component thereof, has been in use.

*d. Tools and Equipment, Column (4).* This column is provided for referencing by code the special tools and test equipment (sec. III), required to perform the maintenance functions (sec. II).

*e. Remarks, Column (5).* This column is provided for referencing by code the remarks (sec. IV) pertinent to the maintenance functions.

#### **B-3. Explanation of Columns in Section III**

*a. Reference Code.* This column consists of a number and a letter separated by a dash. The number references the T&TE requirements listed in Section II. The letter represents the specific maintenance function the item is to be used with in columns A through K of Section II.

*b. Maintenance Level.* This column shows the lowest level of maintenance authorized to use the special tool or test equipment.

*c. Nomenclature.* This column lists the name or identification of the tool or test equipment.

*d. Tool Number.* This column lists the manufacturer's code and part number, or Federal stock number of tool or test equipment.

#### **B-4. Explanation of Columns in Section IV**

*a. Reference Code.* This column consists of two letters separated by a dash (entered from col. (5) of Sec. II). The first letter references alpha sequence in column (5) and the second letter references a maintenance function, column (3), A through K.

*b. Remarks.* This column lists information pertinent to the maintenance function to be performed (as indicated in sec. II).

## Section II. MAINTENANCE ALLOCATION CHART

(1) Group No.	(2) Assembly group	(3) Maintenance functions											(4) Tools and equipment	(5) Remarks		
		A	B	C	D	E	F	G	H	I	J	K				
		Inspect	Test	Service	Adjust	Align	Calibrate	Install	Replace	Repair	Overhaul	Rebuild				
01	<b>MISCELLANEOUS</b>															
	Generator Receptacle and Cables .....	O							O	O						
	Suction Strainer .....	C		C					O							
	Suction Hose .....	C							C	O						
	Shower Stand and Pump															
	Hoses .....	C							C	O						
	Baseboard .....	O		C					O	F						
	Burner Exhaust Duct .....	O		O					O							
02	<b>SHOWER STAND AND PUMP ASSEMBLY</b>															
	Shower Stand .....	O		O					O							
	Nozzle .....	C		C					C							
	Riser .....	O							O	F						
	Valve, flow control .....	O							O							
	Water Pump Assembly .....	O		O					O							
	Water Line Strainer .....	C		C					O							
	Frame .....	O							O	F						
	Electrical Motor .....	O							O							
	Water Pump .....	O		O	O				O	O						
	Control Assembly .....	O							O	O						
	Conduit, Electrical Fittings and Wiring .....	O							O	O						
03	<b>WATER HEATER ASSEMBLY</b>															
	Fuel Hose and Barrel															
	Plug .....	O							O							
	Ignition Transformer .....	O	F						O							
	Skid .....	O							O	F						
	Boiler Cover .....	O							O							
	Burner Assembly .....	O		O	O				O	O						
	Manifold Connections															
	Upper manifold relief valve and elbows .....	O							O							
	Pressure relief valve overflow and tube .....	O							O							
	Bypass hose .....	O							O							
	Shower stand control and water blender valves .....	O							O							
	Tank, Welded .....	O							F	F						
	Bath unit instructional plate .....	O							O							
	Water Heater Control Assembly .....	O	O		F				O							
	Fuel Pump Assembly .....	O		O	O				O	F						
	Fuel Fittings and Lines .....	O		O					O							
	Motor, Electrical .....	O							O	H						
	Blower Assembly .....	O							O	O						
	Shutter Assembly .....	O			C				O							
	Conduit, Electrical Fittings and Wiring .....	O							O	O						



# APPENDIX C

## BASIC ISSUE ITEMS LIST AND ITEMS TROOP

### INSTALLED OR AUTHORIZED LIST

#### Section I. INTRODUCTION

##### C-1. Scope

This appendix lists items which accompany the bath unit or are required for installation, operation, or operator's maintenance. Repair Parts and Special Tools assigned maintenance code "C" in the organizational portion of the Maintenance Repair Parts and Special Tools List Manuals, may be stocked at the operator level of maintenance when authorized by the Unit Commander.

##### C-2. General

This Basic Issue Items List is divided into the following sections:

*a. Basic Issue Items—Section II.* A list of items which accompany the bath unit and are required by the crew / operator for installation, operation, or maintenance.

*b. Maintenance and Operating Supplies—Section III.* Not applicable.

##### C-3. Explanation of Columns

The following provides an explanation of columns in the tabular list of Basic Issue Items, section II.

*a. Source, Maintenance, and Recoverability Codes (SMR);*

(1) Source code, indicates the source for the listed item. Source Codes are:

<i>Code</i>	<i>Explanation</i>
P	Repair parts, Special Tools and Test Equipment supplied from the GSA / DSA, or Army supply system and authorized for use at indicated maintenance categories.
P2	Repair parts, Special Tools and Test Equipment which are procured and stocked for insurance purposes because the combat or military essentiality of the end item dictates that a minimum quantity be available in the supply system.
M	Repair parts, Special Tools and Test Equipment which are not procured or stocked, as such, in the supply system but are to be manufactured at indicated maintenance levels.
A	Assemblies which are not procured or stocked as such, but are made up of two or more units. Such component units carry individual stock numbers and descriptions, are procured and stocked separately and can be assembled to form the required assembly at indicated maintenance categories.

##### *Code*

##### *Explanation*

X	Parts and assemblies that are not procured or stocked because the failure rate is normally below that of the applicable end item or component. The failure of such part or assembly should result in retirement of the end item from the supply system.
X1	Repair parts which are not procured or stocked. The requirement for such items will be filled by use of the next higher assembly or component.
X2	Repair parts, Special Tools and Test Equipment which are not stocked and have no foreseen mortality. The indicated maintenance category requiring such repair parts will attempt to obtain the parts through cannibalization or salvage, if not obtainable through cannibalization or salvage, the item may be requisitioned with exception data, from the end item manager, for immediate use.
G	Major assemblies that are procured with PEMA funds for initial issue only as exchange assemblies at DSU and GSU level. These assemblies will not be stocked above DS and GS level or returned to depot supply level.

##### NOTE

Cannibalization or salvage may be used as a source of supply for any items source coded above except those coded X1 and aircraft support items as restricted by AR 700-42.

(2) Maintenance code, indicates the lowest category of maintenance authorized to install the listed item. The maintenance level code is:

<i>Code</i>	<i>Explanation</i>
C	Operator or crew
O	Organizational

(3) Recoverability code, indicates whether unserviceable items should be returned for recovery or salvage. Items not coded are non-recoverable. Recoverability codes are:

<i>Code</i>	<i>Explanation</i>
R	Applied to Repair parts, (assemblies and components) Special Tools and Test Equipment which are considered economically repairable at direct and general support maintenance levels. When the item is no longer economically repairable, it is normally disposed of at the GS level. When supply considerations dictate, some of these repair parts may be listed for automatic

Code	Explanation
S	return to supply for depot level repair as set forth in AR 710-50. When so listed, they will be replaced by supply on an exchange basis. Repair parts, Special Tools, Test Equipment and assemblies which are economically reparable at DSU and GSU activities and which normally are furnished by supply on an exchange basis. When items are determined by a GSU to be uneconomically reparable, they will be evacuated to a depot for evaluation and analysis before final disposition.
T	High dollar value recoverable Repair parts, Special Tools and Test Equipment which are subject to special handling and are issued on an exchange basis. Such items will be evacuated to the depot for overhaul or final disposition. Communication-Electronics and Missile Support items will be repaired/overhauled only at depots.
U	Repair parts, Special Tools and Test Equipment specifically selected for salvage by reclamation units because of precious metal content, critical materials, high dollar value or reusable casings or castings.

*b. Federal Stock Number.* This column indicates the Federal stock number assigned to the item and will be used for requisitioning purposes.

*c. Description.* This column indicates the Federal item name and any additional description of the item required. The abbreviation "w/e", when used as a part of the nomenclature, indicates

the Federal stock number, includes all armament, equipment, accessories, and repair parts issued with the item. A part number or other reference number is followed by the applicable five-digit Federal supply code for manufacturers in parenthesis. The usable on codes indicate different model and serial number application. Repair parts quantities included in kits, sets, and assemblies are shown in front of the repair part name.

*d. Unit of Measure (U/M).* A two-character alphabetic abbreviation indicating the amount or quantity of the item upon which the allowances are based, e.g., ft, ea, pr, etc.

*e. Quantity Incorporated in Unit.* This column indicates the quantity of the item used in the assembly group. A "V" appearing in this column in lieu of a quantity indicates that a definite quantity cannot be indicated (e.g., shims, spacers, etc.).

*f. Quantity Furnished With Equipment.* This column indicates the quantity of an item furnished with the equipment.

*g. Illustration.* This column is divided as follows:

(1) *Figure Number.* Indicates the figure number of the illustration in which the item is shown.

(2) *Item Number.* Indicates the callout number used to reference the item in the illustration.

## Section II. BASIC ISSUE ITEMS

(1) SMR code	(2) Federal stock number	(3) Description  Ref No. & Mfr Code  Usable on code		(4) Unit of meas	(5) Qty inc in unit	(6) Qty furn with equip	(7) Illustration	
							(A) Fig No.	(B) Item No.
PO	4210-270-4512	EXTINGUISHER, FIRE, CARBON DIOXIDE: Hand type; Charged, 10 lb. Cap.		EA		1	4	2-5

# ALPHABETICAL INDEX

	Paragraph	Page		Paragraph	Page
<b>A</b>					
Adjustment:			Data, tabulated	1-6 <i>b</i>	1-2
Electrode	4-33 <i>e</i>	4-34	Demolition	1-1 <i>b</i>	1-1
Fuel pump	4-41 <i>a</i> (5)	4-49	Description	1-4	1-1
Pressure and temperature control	6-14 <i>a,b</i>	6-13	Differences in models	1-5	1-2
Water pump	4-26 <i>f</i>	4-22	Dismantling bath unit	2-3	2-12
Air nose, burner	4-38	4-43	Drain cocks:		
Auxiliary equipment:			Combustion chamber	4-33	4-33
Fire extinguisher	2-16,2-17	2-22,2-23	Pressure control line	4-40 <i>n</i>	4-49
Fuel drum	2-16	2-22	Water pump	4-33	4-33
Generator set	2-16	2-22	Draining bath unit	2-3 <i>a</i>	2-12
<b>B</b>					
Barrel plug	4-29	4-26	Duct, exhaust	4-18	4-11
Baseboard and straps	3-8,4-17,	3-6,4-40,	Dust cap, water pump		
	6-2	6-1	prime port	4-23	4-14
Bath unit instructional plate	4-39	4-44	<b>E</b>		
Bath unit, uncrating, unloading,			Electric motors	4-25,4-33, 4-18,4-33	
and unpacking	4-2—4-4	4-1		6-13	6-11
Blower and fuel pump motor	4-43,6-13	4-56,6-11	Electrode cable assembly	4-30 <i>b</i> (4)	4-28
Blower housing and gasket	4-45 <i>a</i>	4-57	Electrodes, burner	4-33	4-33
Blower motor conduit tube and wires	6-14	6-13	Element, line strainer	3-11	3-9
Blower shutter, adjustment	2-6 <i>c</i>	2-12	Errors, reporting of	1-3	1-1
Blower shutter assembly	4-44 <i>a,b</i>	4-57	Exhaust duct	4-18	4-11
Blower wheel	4-45 <i>b</i>	4-57	<b>F</b>		
Bracket, transformer mounting	4-30	4-27	Forms and records	1-2	1-1
Burner:			Frame, water pump	4-24	4-15
Air nose	4-33	4-33	Fuel filter and bracket	4-41 <i>c,d,e</i>	4-52,4-55
Electrodes and holder	4-33	4-33	Fuel fittings and line assemblies	4-42	4-56
Fuel control and shutoff valves	4-40 <i>l</i>	4-48	Fuel pump	4-41 <i>a</i>	4-49
Fuel nozzle, adapter, and nipple	4-33	4-33	Fuel pump assembly	6-12	6-9
Head	4-33	4-33	Fuel pump bracket with stop		
Ignition transformer	4-30	4-27	pin	4-41 <i>e</i>	4-55
Sight hole cap assembly	4-33	4-33	Fuel pump coupling	4-41 <i>f</i>	4-56
Sight tube glass	4-33	4-33	Fuel pump pressure gage		
Solenoid valve	4-40 <i>i</i>	4-48	and dampener	4-40 <i>j</i>	4-48
Bypass hose	4-36	4-41	Fuel pump strainer	4-41 <i>b</i>	4-52
<b>C</b>					
Cable, power cord	4-14	4-7	<b>G</b>		
Cap assembly, sight hole	4-33	4-33	Gage, fuel pump pressure	4-40 <i>j</i>	4-48
Cap, line strainer	3-11	3-9	Gage, water heater temperature	4-40 <i>k</i>	4-48
Circuit breaker overload heaters	4-27 <i>b</i>	4-23	General cleaning	5-7	5-2
Conduit	4-27 <i>d</i> 4-40 <i>m</i> ,	4-24,4-49,	General inspection	5-8	5-2
	6-6,6-14	6-3, 6-13	General repair	5-9	5-2
Conduit tube, blower motor	6-14	6-13	Generator maintenance	4-13	4-7
Conduit tube, transformer	4-30 <i>b</i> (3)	4-27	Generator receptacle box cable	4-14	4-7
Conduit tube, water pump	6-6	6-3	<b>H</b>		
Control panel box bracket	4-40 <i>g</i>	4-46	Heaters, circuit breaker overload	4-27 <i>b</i>	4-23
Control panel box cover	4-40 <i>b</i>	4-44	Holder, burner nozzle and		
Control panel box receptacle			electrode	4-33	4-33
connector	4-40 <i>c</i>	4-44	Hose assemblies:		
Control panel boxes, water heater			Fuel feed and return	4-29	4-26
and pump	4-27 <i>c</i>	4-23	Water	3-7,4-16	3-5,4-9
Control panel circuit breaker			Hose, bypass	4-36	4-41
subassembly	4-27 <i>a</i> , 4-40 <i>d</i>	4-22,4-44	Housing, water pump	4-25	4-18
Control panel switch cover	4-40 <i>a</i>	4-44	<b>I</b>		
Control, pressure and temperature	4-40 <i>f</i> , 6-11	4-46,6-5	Ignition transformer	4-30,6-8	4-27,6-3
Coupling-half	3-6,4-15	3-4,4-9	Impeller, water pump	4-26	4-22
<b>D</b>					
Dampener, fuel pump pressure			Inspecting and servicing	4-5	4-2
gage	4-40 <i>j</i>	4-48			



	Paragraph	Page
Inspection and maintenance of bath unit in storage .....	7-1,7-2	7-1,7-2
Instructional plate, bath unit .....	4-39	4-44
<b>L</b>		
Level, skid .....	4-31	4-30
<b>M</b>		
Models, difference .....	1-5	1-2
Motor mounting plate .....	4-43	4-56
Motors:		
Blower and fuel pump .....	4-43,6-13	4-56,6-11
Water pump .....	4-25	4-18
<b>N</b>		
Nozzle and electrode holder .....	4-33	4-33
Nozzle, burner fuel .....	4-33	4-33
<b>O</b>		
Operation in:		
Cold weather .....	2-14	2-22
Dusty weather .....	2-15	2-22
Unusual conditions .....	2-13—2-15	2-22
Orientation .....	1-6a	1-2
Overflow tube, pressure relief valve .....	4-35	4-39
<b>P</b>		
Pipe tee and nipple .....	4-26b	4-22
Plate:		
Motor mounting .....	4-25	4-18
Vane .....	4-25	4-18
Plug, barrel .....	4-29	4-26
Power cord cables, connectors, and shields .....	4-27e	4-25
Preparation of bath unit for storage .....	7-1	7-1
Preparing bath unit for:		
Movement .....	2-3,2-4	2-12
Operation .....	2-8—2-10	2-18
Storage .....	7-1	7-1
Pressure and temperature control .....	4-40f, 6-11	4-46,6-5
Changeover procedures .....	4-40h	4-46
Pressure gage .....	4-40j	4-48
Pressure relief valve overflow tube .....	4-35	4-39
Preventive maintenance services:		
Operator .....	3-2	3-3
Organizational .....	4-10	4-3
Pump, fuel .....	4-41	4-49
Pump, water .....	4-26	4-22
<b>R</b>		
Reducing couplings .....	4-21	4-13
Repair parts .....	4-8	4-2
<b>S</b>		
Sediment strainer cap .....	4-23	4-14
Selecting a site .....	2-2a	2-1
Service upon receipt of bath unit .....	3-1	3-1
Setting up bath unit .....	2-9	2-18
Shipment and limited storage .....	7-1	7-1

	Paragraph	Page
Shower stand:		
Flow control valve .....	4-37	4-42
Guard .....	4-19b	4-12
Head .....	4-19c	4-12
Leg .....	4-19d	4-12
Nozzles .....	3-10	3-7
Reducing couplings .....	4-21	4-13
Riser .....	4-20,6-4	4-13,6-3
Shutoff valve, burner fuel .....	4-40i	4-48
Shutters, blower .....	2-6c, 4-44a,b	2-12,4-57
Sight tube glass, electrode .....	4-33	4-33
Skid, water heater .....	4-31,6-9	4-30,6-5
Solenoid valve, burner .....	4-40i	4-48
Starting bath unit .....	2-10	2-20
Stopping bath unit .....	2-12	2-22
Storage:		
Preparation .....	7-1	7-1
Inspection .....	7-2	7-2
Maintenance .....	7-2	7-2
Strainer element .....	3-11	3-9
Strainers:		
Fuel pump .....	4-41b	4-52
Water line .....	3-11,4-23	3-9,4-14
Suction .....	3-6,4-15	3-4,4-9
Straps, baseboard .....	4-17	4-10
<b>T</b>		
Tabulated data .....	1-6b	1-2
Tank, water heater, welded .....	4-38,6-10	4-43,6-5
Tools and equipment .....	4-6	4-2
Transformer-to-burner electrode ignition cable assembly .....	4-30b (4)	4-28
Transformer conduit tube and wires .....	4-30b (3)	4-27
Transformer mounting bracket .....	4-30b (2)	4-27
Transformer, ignition .....	4-30	4-27
Troubleshooting:		
Operator .....	3-4	3-3
Organizational .....	4-12	4-5
Direct and general support .....	5-5	5-1
Tube, conduit .....	4-27d, 4-40m, 6-6,6-14	4-24,4-49, 6-3,6-13
Tube, pressure relief valve overflow .....	4-35	4-39
<b>U</b>		
Uncrating, unloading, and unpacking bath unit .....	4-2—4-4	4-1
<b>V</b>		
Valves:		
Burner fuel control .....	4-40i	4-48
Burner fuel shutoff .....	4-40i	4-48
Shower stand control .....	4-37	4-42
Shower stand flow control .....	4-21	4-13
Solenoid .....	4-40i	4-48
Upper manifold relief .....	4-34	4-38
Water blender .....	4-37	4-42
Vane plate, water pump .....	4-25	4-18
<b>W</b>		
Water heater maintenance:		
Boiler cover .....	4-32	4-31
Control panel box .....	4-40b,e	4-44,4-45

	Paragraph	Page		Paragraph	Page
Control panel box bracket .....	4-40 <i>g</i>	4-46	Wheel, blower .....	4-45 <i>b</i>	4-57
Temperature gage .....	4-40 <i>k</i>	4-48	Wiring and wires, water		
Pressure control line			heater .....	6-14	6-13
drain cock .....	4-40 <i>n</i>	4-49	Wiring diagrams:		
Water pump .....	4-26	4-22	Generator receptacle box .....	4-14	4-7
Water pump maintenance .....	3-11,4-22—4-27, 6-5,6-6	3-9,4-14, 6-3	Power cord cable .....	4-26 <i>e</i>	4-22
			Water heater .....	4-30	4-27
			Water pump .....	4-25	4-18
Water pump motor .....	4-25	4-18	Wiring, water pump .....	4-27 <i>d</i>	4-24



**By Order of the Secretary of the Army:**

**W. C. WESTMORELAND,**  
*General, United States Army,*  
*Chief of Staff.*

**Official:**

**VERNE L. BOWERS,**  
*Major General, United States Army,*  
*The Adjutant General.*

**Distribution:**

**To be distributed in accordance with DA Form 12-25A, (qty rqr block no. 170)**  
**Organizational maintenance requirements for Shower and Bath.**

★ U.S. GOVERNMENT PRINTING OFFICE : 1990 O - 261-872 (20893)





# SOMETHING WRONG WITH THIS MANUAL?

THEN... JOT DOWN THE DOPE ABOUT IT ON THIS FORM, TEAR IT OUT, FOLD IT AND DROP IT IN THE MAIL!

FROM: (YOUR UNIT'S COMPLETE ADDRESS)  
 PFC JOHN DOE  
 CoA, 3<sup>rd</sup> ENGINEER BN  
 FT. LEONARD WOOD MO 63108  
 DATE 16 DEC 74

PUBLICATION NUMBER: TM5-6115-200-20 AND P      DATE: 1 APR 72      TITLE: GENERATOR SET 10 KW  
 NSN 6115-00-231-7286

BE EXACT... PIN-POINT WHERE IT IS				IN THIS SPACE TELL WHAT IS WRONG AND WHAT SHOULD BE DONE ABOUT IT:
PAGE NO.	PARAGRAPH	FIGURE NO.	TABLE NO.	
6	2-1 a			In line 6 of paragraph 2-1a the manual states the engine has <u>6</u> cylinders. The engine on my set only has <u>4</u> cylinders. Change the manual to show <u>4</u> cylinders
81		4-3		Callout <u>16</u> on figure 4-3 is pointing at a <u>bolt</u> . In the key to fig. 4-3, item 16 is called a <u>shim</u> . Please correct one or the other
125	line 20			I ordered a gasket, item 19 on figure B-16 by NSN 2910-00-762-3001. I got a gasket but it doesn't fit. Supply says I got what I ordered so the NSN is wrong. Please give me a good NSN

TEAR ALONG DOTTED LINE

TYPED NAME, GRADE OR TITLE, AND TELEPHONE NUMBER: JOHN DOE, PFC (268) 317-7111      SIGN HERE: John Doe

FILL IN YOUR  
UNIT'S ADDRESS

FOLD BACK

DEPARTMENT OF THE ARMY

OFFICIAL BUSINESS

Commander  
US Army Troop Support Command  
ATTN: DRSTS-MPP  
4300 Goodfellow Blvd.  
St. Louis, MO 63120

CUT ALONG DOTTED LINE

FOLD BACK

REVERSE OF DA FORM 2026-2 (TEST)









