



Copyright Reserved.

3

40
—
W.O.
—
7153

NOTES

ON THE AMMUNITION FOR

Q.F. 4.5-INCH HOWITZER.

4TH EDITION.

1920.



LONDON:
PUBLISHED BY HIS MAJESTY'S STATIONERY OFFICE.

To be purchased through any Bookseller or directly from
H.M. STATIONERY OFFICE at the following addresses:
IMPERIAL HOUSE, KINGSWAY, LONDON, W.C. 2, and 29, ABINGDON STREET, LONDON, S.W. 1.
37, PETER STREET, MANCHESTER; 1, ST. ANDREW'S CRESCENT, CARDIFF;
28, FORTH STREET, EDINBURGH;
or from E. PONSONBY, LTD., 116, GRAFTON STREET, DUBLIN.

Price One Shilling Net.

24696

40
W.O.
7153

NOTES ON THE AMMUNITION FOR Q.F. 4.5-INCH HOWITZER.



LONDON:
PUBLISHED BY HIS MAJESTY'S STATIONERY OFFICE.

To be purchased through any Bookseller or directly from
H.M. STATIONERY OFFICE at the following addresses:
IMPERIAL HOUSE, KINGSWAY, LONDON, W.C. 2, and 28, ABINGDON STREET, LONDON, S.W. 1;
37, PETER STREET, MANCHESTER; 1, ST. ANDREW'S CRESCENT, CARDIFF;
28, FORTH STREET, EDINBURGH;
or from E. PONSONBY, LTD., 110, GRAFTON STREET, DUBLIN.

Price One Shilling Net.

THESE notes are intended for the information of officers as to the details of the ammunition issued for use with their equipments, and they supplement the regular Treatise and Handbooks.

It must be clearly understood that they are no authority in themselves, and that the official authority is contained in Lists of Changes published every month with Army Orders.

Descriptions are complete to December, 1919.

CONTENTS.

	PAGE
General Notes	3
Table of Main Details of Ammunition	4, 5
Cartridge Cases	6, 7
Primer, Percussion, No. 1	8-10
Cartridges	11-21
General Notes on Shells	22-26
High-Explosive Shells	26-33
Markings on H.E. Shells	34, 35
Incendiary Shells	36-39
Smoke Shells	40, 41
Chemical Shells	42, 43
Packing	44
Markings on Packages	45-47
General Notes on Fuzes	48
Percussion Fuzes	49-52
Fuze, Percussion, D.A., No. 44	53-55
Fuzes, Percussion, D.A., Nos. 106 and 106 E	56-60
Fuze, Percussion, No. 101 E	61-63
Fuze, Graze, No. 100	63
Fuzes, Percussion, Nos. 101 and 102	63
Fuze, Percussion, No. 103	65
Gaines, Nos. 2 and 4	66-68
Time, and Time and Percussion Fuzes	69-71
Fuze, T. and P., No. 82	72-74
Fuze, T. and P., No. 83	75-77
Fuze, T. and P., No. 88	78-80
Preservation of Fuzes	81, 82
Glossary	83, 84

GENERAL NOTES.

The ammunition issued with the Q.F. 4.5-inch howitzer equipment is not of the fixed type. The propellant charge is contained in a brass cartridge case which also acts as a sealing-device for the propellant gases, but the cartridge case and projectile are not secured together and must be loaded separately into the howitzer.

When loading, it is necessary that the projectile should be well rammed into the bore of the howitzer, and that an equal pressure of ramming should be exerted at successive rounds. If the projectile is not rammed home, it may slip back when the piece is elevated, enter the cartridge case and rest on the propellant charge; this would probably lead to irregular shooting, and might give rise to excessive pressures in the chamber of the piece. Also if a varying pressure is exerted when ramming successive rounds, the projectiles may be forced for varying distances into the bore, with the result that the density of loading, or, in other words, the effective chamber space provided for the charge, will vary; such variations lead to irregularities in shooting.

A number of different natures of projectiles are issued with this equipment. The different natures are distinguished by the colours in which the projectiles are painted and by distinctive markings.

When circumstances permit, lists should be kept for each gun of the particulars of the ammunition provided for it, in the order in which it is to be expended. Particulars should include designation and mark, design number of the method of filling, initials or monogram of manufacturer, monogram of filling station and date of filling, and lot number. The information enables faulty rounds to be identified, and is of assistance in tracing causes of failure.

When packed in limbers and wagons, two complete rounds fit into each basket carrier, which is inserted in a compartment of the wagon or limber box. A wagon with its limber contains 48 rounds (32 + 16) and a carriage limber 12 rounds.

TABLE OF MAIN DETAILS

CARTRIDGE CASE.	Solid-drawn brass case (p. 15) holding the breech-opening.	
PROPELLANT Charge.	Normal charge of Cordite M.D., Cordite (pp. 11 to 16).	
MEANS OF IGNITION.	No. 1 percussion primer (p. 8) screwed	
PROJECTILE.	High Explosive (p. 26).	
Filling.	Amatol, Lyddite, or Trotyl. + An exploder of Trotyl or C.E.	
FUZE ...	Graze No. 100 (p. 63), or Percussion, Nos. 101, 101 E, 102 or 103 (pp. 61 and 63) in conjunction with a gaine No. 2 ; or Fuze Percussion No. 106 (p. 56) ; or T. and P. No. 83 (p. 75).	

OF AMMUNITION.

propellant charge and acting as the sealing-device for the

R.D.B. flake, Ballistite, or N.C.T., divided into sections

into the base of cartridge case.

PUBLIC LIBRARY OF VICTORIA	<p>Incendiary (p. 36).</p> <p>Thermit, or incendiary stars. + A special explosive or gunpowder.</p>	<p>Smoke (p. 40).</p> <p>Phosphorus. + A small charge of high explosive.</p>	<p>Chemical (p. 42).</p> <p>Liquids of secret Composition. + A small charge of high explosive.</p>
	<p>T. and P. Nos. 82 (p. 72) or 83 (p. 75).</p>	<p>Percussion Nos. 44 (p. 53) or 106 (p. 56).</p>	<p>Percussion Nos. 44 (p. 53) or 106 (p. 56).</p>

CARTRIDGE CASES.

The propellant charge is contained in a solid-drawn brass case (p. 15). The base of the case is integral with the walls, and is provided with a central screw-threaded opening for the primer, and with an external rim that acts as a stop when loading and as a projection to engage the extractor of the breech-mechanism. The case for the whole of its length is a close fit in the chamber of the howitzer; and to facilitate extraction, the case, and the chamber, are slightly tapered.

The case acts both as a container for the propellant charge and as a sealing-device for the breech-opening, preventing the escape of propellant gases to the rear; by the pressure of these gases, the case is expanded and forced tightly against the walls of the chamber. When the pressure is released, the case, owing to the natural elasticity of its metal,* draws away from the walls of the chamber, it can then be freely extracted. For the case to behave in this manner, its walls must be thin. But as the walls are thin, the case must not be subjected to rough usage; if dented or distorted, a jam may occur when an attempt is made to load the round; or if the round is loaded and then fired, the propellant gases may escape over the case and cause serious damage to the piece.

Therefore, if the sealing is to be perfect, the case must be in an undamaged condition; in addition, it must be clean, that is, free from mud, dirt, and corrosion. If the case is not clean, difficulties may occur when an attempt is made to extract it.

Cases are repaired and refilled a number of times. The normal life of a case, that is, the number of times it is considered safe for it to be used, was formerly represented by six full charges, but now depends on serviceability of the

* If the metal of the case is too hard, cracks or splits are liable to develop. Hardening of the metal takes place during manufacture and repair, and on firing; it is removed by annealing the cases in a furnace. On the other hand, if the metal is too soft, the cases may be difficult to extract; but this is avoided by careful annealing and by testing all suspected cases, see p. 19.

case. The letter "C," indicating cordite or its equivalents, N.C.T. and ballistite, is stamped on the base of the case, and each time the case is filled a letter "F" (full) is added.

All fired cases should be carefully collected and returned at the first opportunity.

Cracks may develop in cartridge cases, particularly in those that have been used for a number of rounds. If a crack is detected, the round should be returned and attention should be drawn to the failure; if used, serious damage to the piece may result. It is to prevent the development of cracks that cases are annealed during manufacture and repair.

Information with regard to the case will be found stamped on its base. The information includes:—nature of howitzer, a numeral representing the Mark of the case,* the lot number of the case, and the year of manufacture. A letter "A" denotes that the case has been annealed in the process of repair, and a punch mark is added each time this treatment is carried out; the batch letter and number of the annealing is also included. The general arrangement of the stamping is shown on p. 19.

* The Mark II case is slightly longer than the earlier pattern.

PRIMER, PERCUSSION, No. 1.

With the ammunition of the present equipment the propellant charge is ignited by means of a primer screwed into the cartridge case and co-operating with the percussion firing-mechanism of the gun. Actual ignition of the charge is effected by the firing of a small magazine of gunpowder contained in the primer. Ignition of the magazine fills the cartridge case with a powerful flame which ignites simultaneously all the surfaces of the charge exposed to it; certainty of ignition is essential for regular shooting.

The No. 1 primer which is used with this equipment, is provided with a percussion cap and with a magazine of fine grain gunpowder. The cap is fired by the blow of the striker, and the flash from the cap fires the gunpowder and this in turn ignites the propellant charge.

The magazine is closed by a brass, tin, steel, or glazed-board* disc, treated so as to open out when the primer is fired; it is sealed by a coating of Pettman's cement applied to the closing disc. Occasionally these discs, particularly those of glazedboard, are blown out of the primer. If the blown-out disc rests in the bore of the gun there is a possibility that a jam will occur at the next round.

Primers with glazedboard discs are identified by the letter "B" added to the numeral, thus No. 1, Mark II B. This marking, together with the manufacturer's initials or monogram, and the year of manufacture, will be found stamped on the base of the primer.

Mark II of this primer has a ball fitted in the passage between the percussion cap and the magazine. The ball is blown back into its coned seating and seals the passage against back-rush of the propellant gases. Other marks are not provided with a ball seal; the cup of the cap is relied on to prevent the escape of the gases.

To obtain the best and most certain results, the cap of the primer must be struck centrally. The cases of fired rounds

* Glazedboard closing discs are no longer being used.

PRIMERS, PERCUSSION, Q.F. CARTRIDGES, No. 1.

MARK II.

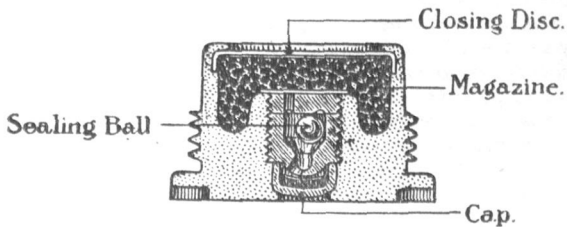

MARK III.

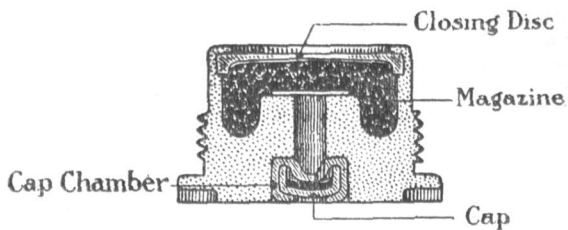

KEY, No. 26.



should therefore be inspected; if the indents on the caps are distinctly eccentric, the striker of the mechanism should be adjusted.

Before inserting the primer, the screw-threads and underside of the flange are coated with Mark III luting so as to form a seal against the entry of moisture. Particularly is this necessary with N.C.T. charges, as this propellant readily absorbs moisture and the regularity of the shooting is affected.

The luting also helps to prevent unscrewing of the primer by the vibration when travelling. But in later cartridges the primers are further secured by punching up the metal of the case at points opposite the slots in the head of the primer. A partly projecting primer may prevent closing of the breech when an attempt is made to load the round.

On the other hand, a missfire may result if the cap of the primer is sunk more than 0.015-inch below the level of the base of the case.

Key No. 26 is used for inserting or removing the primer. The key consists of a steel bar bent to fit over the base of the case, and provided with two studs to engage the slots in the head of the primer.

When issued separately, 4 to 10 primers are packed in a square or circular and flat tin box, the lid of which is sealed by a soldered-on tin strip arranged to be torn off when the box is to be opened. Primers in an opened box should be protected by re-sealing the lid with a tape band secured by shellac cement over the joint, and afterwards coated with the same cement. A temporary seal may be made by Mark III luting smeared inside the flange of the lid.

Primers can be repaired for re-use. On repair, a star, or the letter "M" or "R" is added to the numeral, thus: No. 1, Mark III R.

CARTRIDGES.

The cartridges of the 4.5-inch howitzer equipment present special features ; these are correlated with the design of the howitzer and with its method of use. Thus, as the howitzer is for its calibre of comparatively light weight, and therefore of comparatively low strength, the weight of the charge is small so as to give comparatively low pressures ; a small size of propellant is used so as to obtain complete combustion in the length of the bore, which is short ; the charge is made up in such a form that its weight can be readily adjusted so as to provide for widely-varying ranges and to enable the most suitable angle of descent at any particular range to be obtained.

For the cartridges of this equipment the following propellants have been used :—Cordite M.D. or R.D.B. in the form of strands, N.C.T., Ballistite, and Cordite R.D.B. flake. At present Cordite R.D.B. flake is being largely employed.

In all the cartridges, the charge is divided into five sections, and the weights of the sections are selected so that the full charge and the fractional parts give the same muzzle velocities with each propellant. Each section of the charge is enclosed in a cambric bag, and the sections are packed into the cartridge case in their numerical order, with No. 1 section at the bottom. The different charges are obtained by combinations of the sections taken in their numerical order in all cases starting from No. 1 ; other combinations are not used ; therefore, for the lower charges, the sections not required are removed from the top of the pile and the other sections are left undisturbed in the case.

The bags containing the propellant charges are secured together and to the cartridge case, usually by shellac varnish applied in patches. The sections must be removed with care as the cambric of the bags is easily torn ; if the bag is ruptured, the charge may be spilt.

After loading the cartridge case, its mouth is closed by a leather-board lid or by a flexible rubber cover. The cover is

to be preferred; it seals the case against the entry of moisture (p. 15). The lid or cover is to be removed before loading.

Each complete cartridge is packed in a tin cylinder, the lid of which is sealed by a tape band secured by shellac cement. For some earlier issues, a cardboard cylinder was used; but this did not give so good a protection against the entry of moisture as did the tin cylinder, and its use was therefore discontinued.

A description of the cartridges follows.

The flake cordite cartridge.—The charge for this is 15 ozs. 12 drs. Cordite R.D.B. square flake, size $2\frac{1}{2}/50$; it is divided into five sections of the following weights:—

					ozs.	drs.
Section No. 1	6	0
Section No. 2	1	3
Section No. 3	1	11
Section No. 4	2	10
Section No. 5	4	4

The muzzle velocities given by the different charges are:—

First charge (Section No. 1)	559 f.s.
Second charge (Sections Nos. 1 and 2)	...	630 f.s.	
Third charge (Sections Nos. 1, 2 and 3)	...	709 f.s.	
Fourth charge (Sections Nos. 1, 2, 3 and 4)	...	829 f.s.	
Fifth charge (Sections Nos. 1, 2, 3, 4 and 5)	...	1,010 f.s.	

Each section of the charge is filled into a cambric bag; the sections when completed have the shape of discs or short cylinders of a diameter to fit the case. No. 1 Section is secured to the base of the case by four dabs of shellac varnish; Sections Nos. 2, 3 and 4 are shellaced in four places to the sides of the case, and in addition No. 4 is shellaced to No. 3; No. 5 Section is shellaced to No. 4 in four places; and the charge is sealed by a cambric or muslin strip secured across the uppermost section. Each section is clearly marked with its number and with the weight of the charge contained in it.

CARTRIDGE Q.F., 4.5-INCH HOWITZER.
 FILLED 15 oz. 12 DRS. CORDITE R.D.B. S.F. 2½/50, WITH
 FLEXIBLE COVER.

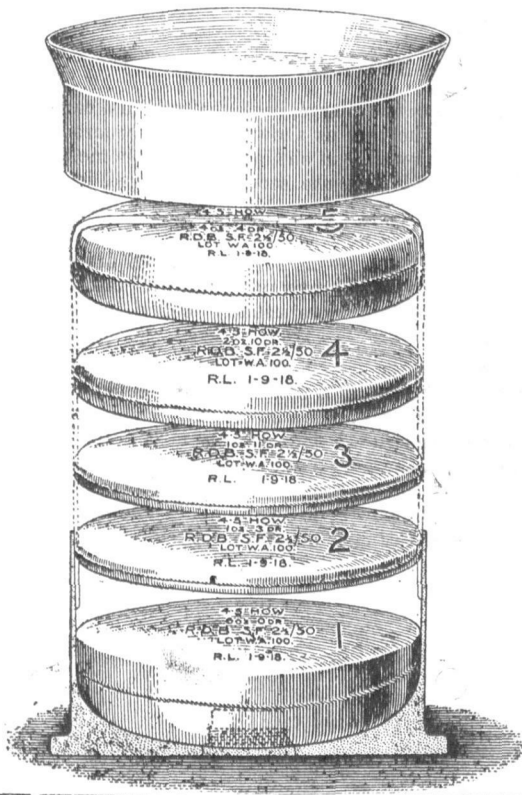

The N.C.T. cartridge.—The charge for this cartridge consists of 1 lb. 2 ozs. 4 drs. N.C.T., size 5; it is divided into five sections of the following weights:—

					ozs.	drs.
Section No. 1	;	7	0
Section No. 2	1	8
Section No. 3	1	13
Section No. 4	2	12
Section No. 5	5	3

The sections of the charge, each enclosed in a cambric bag, are packed in the case as shown, and are secured together and to the case by dabs of shellac cement. Some cartridges have been issued with the sections arranged in a slightly different manner; with these, No. 1 section is lightly attached to the lid.

The N.C.T. charge, owing to the loose nature of the propellant (short cylinders) does not pack well into the Mark I case; it is therefore more usually loaded into the longer Mark II case.

The mouth of the case is closed either by a leather-board lid, or more usually by a flexible rubber cover. The latter is to be preferred as it gives a much greater protection against the entry of moisture. This sealing is of importance with N.C.T. charges, the propellant readily absorbs moisture with the result that the charges swell and may expand out of the case, causing difficulties in loading; in addition, the regularity of the shooting is affected.

CARTRIDGE, Q.F. 4.5-INCH HOWITZER.
 FILLED N.C.T.

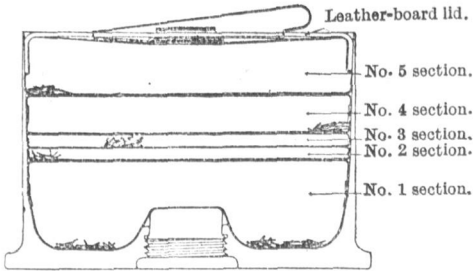

FILLED BALLISTITE.

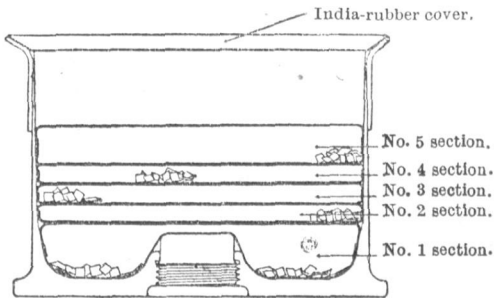

FILLED CORDITE.

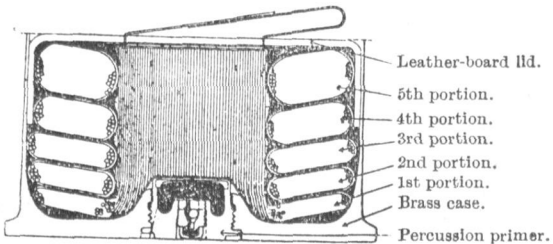

The ballistite cartridge.—The charge for this cartridge consists of 14 ozs. 2 drs. of ballistite A., size 71 ; it is divided into five sections of the following weights :—

					ozs.	drs.
Section No. 1	5	4½
Section No. 2	1	2½
Section No. 3	1	7½
Section No. 4	2	5
Section No. 5	3	14½

The sections are provided with cambric bags, and are packed into the cartridge case in a similar manner to the N.C.T. charge. But as ballistite is a powder which packs closely, the leather-board lid when used, is reversed and fitted into the case with its cupped side uppermost.

The cordite cartridge.—In this cartridge, which was the one originally introduced for this equipment, the arrangement of the charge is different to that of the cartridges described above ; the differences depend on the propellant which is in the form of strands.

The charge consists of 15 ozs. 14 drs. of cordite M.D. or R.D.B., in part of size 2½ and in part of size 4½. It is divided into the usual five sections of which four are shaped as rings ; the fifth section consists of a central core to the end of which a ring-shaped base is attached, and this section rests on the bottom of the cartridge case, and the rings are fitted detachably over the stalk of the core. For the fifth section, the smaller size of propellant is used, so as to ensure completeness of combustion when the lower charges are used, and compensate for the lower chamber pressures.

The weights of the sections are as follows :—

					ozs.	drs.
Core (including its attached ring)	5	14
Second ring	1	5½
Third ring	1	12
Fourth ring	2	9½
Fifth ring	4	5

It is found that different lots of propellants vary slightly in their ballistics. These variations are avoided by increasing or decreasing the weight of the charge. The weights of the charges, given above, are therefore nominal; but the actual variations from these are small. When this adjustment is made, the charge is known as an "adjusted charge"; usually it is denoted by the letters "A.C." *stencilled* on the base of the cartridge case, but with the latest issues this marking is now omitted as is explained later.

Theoretically, all adjusted charges should give the same muzzle velocities. But it is important to note that the firings on which the adjustment is based, are carried out *in a new gun and with the charges at a temperature of 80°F.*; and it is found that irregularities do occur as these conditions are more and more departed from. These irregularities are most pronounced when changing from one nature of propellant to another nature; but they may also occur when changing from one lot of propellant to another of the same nature. That these irregularities should occur is obvious by comparing the temperature-coefficients of the different natures of propellants; they also have their origin in the varying effects produced by wear in the howitzer.

Therefore, to obviate these irregularities in shooting, the cartridges should be grouped on the lot of the propellant. Recently, however, a system has been introduced by which, for general purposes, it is unnecessary to carry out this close grouping. Thus lots of propellants are now classified according to their ballistic properties into groups which are for ranges of 5 f.s. variations in muzzle velocity given by normal charges; the lots above and below normal are given the numbers 10 and 9, and the other groups, higher or lower numbers as the case may be. In addition, each nature of propellant is given a letter, which is "C" for Cordite M.D. or R.D.B. in the form of strands of sticks,* "B" for Ballistite, "N" for N.C.T., and "F" for flake cordite; this marking is introduced in order that the different natures of propellant

* Cordite M.D. and Cordite R.D.B. have now been separated; R.D.B. retains the letter C, but M.D. is given the letter D.

may be kept separate. A complete classification would, therefore, be "F. 10"; and it follows that all lots of propellant in the "F. 10" group have substantially the same ballistic properties, and that it is ordinarily sufficient to group for firing on this basis. But for special purposes, a grouping on the lot of the propellant might be carried out as a refinement.

To enable these groupings to be carried out there is stencilled on the base of the cartridge case and on the package in which the cartridges are packed, the nature of the propellant and its lot letter and number,* and in later issues the ballistic group to which the lot of propellant belongs. The former stencilling is in red; but for the ballistic group different colours are used for the different natures of propellant; thus, for Cordite M.D. or R.D.B. in the form of sticks or strands the colour is blue; for N.C.T., red; for Ballistite, yellow; for flake Cordite, black. This stencilling is enclosed in a rectangle of the same colour. The ballistic group is also stencilled on the tin cylinder in which the cartridge is packed; and as these cylinders are usually blackened, the stencilling, when its distinctive colour is blue or black, is applied to a white patch first painted on the cylinder.

*To enable each lot of propellant to be identified, it is given a letter or letters representing the manufacturer's initial, and a serial number, thus W.A. 1000 (Waltham Abbey, lot 1000).

MARKINGS ON BASE OF CARTRIDGE CASES.
STAMPING.

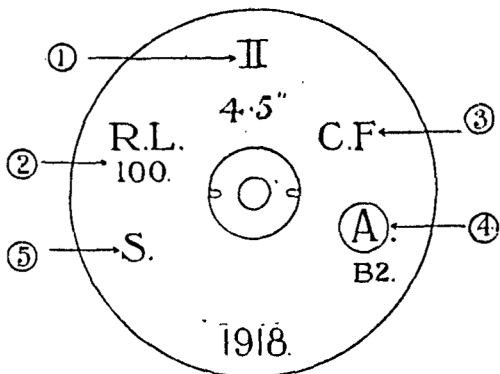

STENCILLING ON BASE.

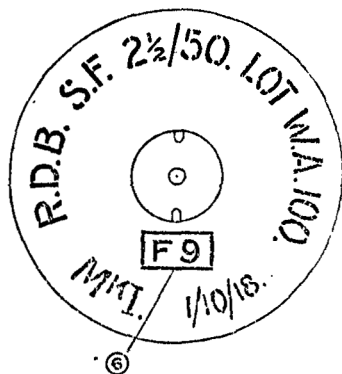

- | | |
|---|--|
| (1) Mark of case. | (4) Annealing markings. |
| (2) Initials or monogram of manufacturer of case, and its lot number. | (5) If the case has been tested for softness (Scleroscope Test.) |
| (3) Life of case. | (6) Ballistic group of propellant. |

In a new gun and with the charges in good condition, the different propellants give about the same accuracy, ballistite and N.C.T. when new being slightly the best. But with N.C.T., which readily absorbs moisture, it is found that the accuracy falls off to a marked extent if the charges have been stored under damp conditions; there is also a general drop in muzzle velocity. This effect of moisture is important; it leads to a permanent injury to the powder; and, in addition, the charges swell and they may expand out of the case, causing difficulties when loading. With other propellants, however, there is evidence that moisture if present in appreciable amounts, affects ballistics, leading to short rounds. Therefore the tin cylinders should not be opened or the covers removed sooner than is necessary; and every effort should be made to protect the cartridges from wet, and to keep the storage conditions as dry as possible.

Wear in the gun produces as its' general effect a loss of muzzle velocity; it is usual to find that there is also a loss of accuracy. The actual losses vary with the different propellants; with flake cordite the losses are pronounced, especially with the lower charges, and it is therefore considered advisable that with worn guns, the first and second charges should not be used; with very worn guns, the use of the third charge should, if possible, be avoided.

The weights of the charges are selected so as to provide for all ranges, and there is also an overlap at each point of change, so that at certain ranges it is possible to use different charges, *cf.* Range Table. Now, wear in the gun is greater as the charge is larger; in the Range Table will be found a table giving the equivalent values as regards wear of the different charges. Therefore to prolong the life of the gun as much as possible, it is desirable that the lower charge should where possible be selected, due consideration being given to the regularity of the shooting and accuracy in the fuze-burst likely to be obtained. By the use of the lower charge a larger angle of descent is obtained.

All propellants deteriorate slowly on storage. With war-time expenditure of ammunition, this will not lead to

harmful results ; but it is advisable that cartridges should be expended according to the date of their manufacture.

¶ With all the propellants used with this equipment there is produced on firing, both flash and smoke. The relative amounts vary : in the case of the cordites and ballistite, the flash predominates ; with N.C.T. there is decidedly more smoke and the flash is appreciably dimmed. The flash and smoke each tend to disclose the position of the batteries, the former more particularly by day, and the latter by night. There is therefore a greater possibility of disclosure by day when firing with N.C.T., and less at night ; and with the other propellants, *vice versa*.

¶ For use with the flake cordite cartridge there is issued a flash-reducing charge consisting of a small amount of a mineral salt enclosed in a circular and flat cambric bag. This charge must be placed on top of the propellant charges so that when loaded it is adjacent to the base of the projectile. In this position it does not affect the ignition of the propellant charge.

¶ When using this charge there is a noticeable reduction in the size and brilliancy of the flash ; but the smoke is increased considerably, and the use of this charge by day is not considered advisable.

Care must be taken not to confuse this charge with the sections of the propellant charge ; although both are in similarly-shaped bags yet there should be no difficulty as the bags are clearly marked.

The flash-reducing charges are packed eight in a cartridge cylinder, and ten of these cylinders are packed in the usual wood box.

GENERAL NOTES ON SHELLS.

The shells of the 4.5-inch equipment have cylindrical bodies, hollow to receive the filling and provided with flat bases and with tapered heads of ogival section. The bases are of a strength sufficient to withstand the pressures of the propellant gases; and the walls, of such a strength and thickness as will prevent bulging or fracture under the firing stresses. The design is therefore largely determined by the stresses to which the shell will be subjected on firing.

The diameter of the body is slightly less than that of the bore across the lands so as to provide a clearance or "windage" that ensures the free passage of the projectile along the bore. The amount of windage with the 4.5-inch howitzer shells is about 0.01 — 0.03 inch.

By giving the heads the ogival shape above referred to, the resistance of the air to the passage of the shell is decreased, so enabling an increased range to be obtained. In longitudinal section, the ogive consists of an arc of a circle having its centre on a line drawn through the shoulders, that is the junction of the head and the cylindrical body. The radius of the head is expressed in calibres. Thus, the shells of the present equipments have heads of about 3 calibres radius; they are termed 3 c.r.h. shells. The fuze, which is fitted into a screwed socket in the nose of the shell, continues the curve of the head.

An important detail of the shell is the driving band. It consists of a ring or strip of copper pressed into a groove in the walls of the shell near the base. The band acts as a seal for the propellant gases; a stop to regulate ramming; a support for the shell when the piece is elevated; and the means by which the rifling imparts rotation to the shell.

To prevent rotation of the band with respect to the shell, waved ribs or knurling into which the copper is pressed, are formed along the bottom of the groove; in addition the sides of the groove are undercut.

The band projects from the shell, and is of a diameter greater than that of the bore across the grooves so as to seal

the gases. Sufficient metal is arranged in the portion which projects, to form a grip for the rifling. With the 4.5-inch shells, two sections of driving bands are used; the earlier was a wide band with two cannellures; but later shells are fitted with a band narrower in width but projecting farther from the shell so as to give a more effective sealing with a gun that is worn. Both patterns of bands have a forward slope which is serrated so as to grip better into the lead of the bore; and it is important if regularity of shooting is to be obtained that the same force of ramming should be exerted at each round.

DRIVING BANDS.

EARLIER PATTERN.

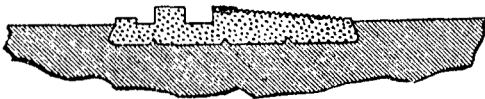

LATER PATTERN.

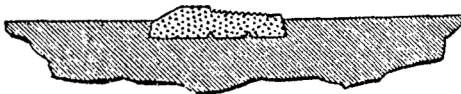

Those shells which are fitted with the later pattern of band are distinguished by two black or white strips painted longitudinally on the body. As the shells with the two patterns of bands may not range alike, it is important that they should be grouped on this marking.

For the band to be engraved by the rifling, the metal used must be soft; but the use of soft metal (copper) renders the band liable to damage. If the band is dented or distorted, a gap may be left through which the propellant gases can

escape, or it may prevent the shell being properly rammed home; these conditions lead to erosion of the bore, and to unsteadiness of the shell in flight.

At each round a small portion of the metal of the driving band is detached and remains firmly adherent in the bore producing the so-called "copper choke." When the choke becomes excessive, de-coppering is necessary; this necessitates the gun being put out of action for a time. Recently it has been found that the choke can be removed by adding to the propellant charge a small amount of tinfoil; the foil is cut into strips 1-inch. in width, crumpled and made up into a bundle of about the diameter of the cartridge case, and placed between the charge and the shell.* For the process to be successful, it is essential that the gun should be absolutely free from grease and graphite lubricant; also it must be hot.

Before loading, care should be taken that the driving bands,—and the shells and cartridges,—are free from mud dirt and rust. Dirt, if present in an excessive amount, may form a bank in advance of the shell travelling along the bore, and if the windage is unable to accommodate it, either the gun must bulge or the walls of the shells set in; the latter will probably lead to either a premature in the bore or a break-up at the muzzle. Similar dangers arise from an excess of lubricant in the bore.

Cleanliness of shells and driving bands is an important safeguard against prematures. It has also a material effect in increasing the life of the gun.

To prevent rusting of the shells they may be lightly oiled. Dirt that may have accumulated in the cannelures of the driving bands, should be carefully brushed out.

Differences may occur in the ranging of the different natures of shell and also of the same nature of shell when fitted with different fuzes.† These differences depend largely on the

* A decoppering charge has not yet been approved for this howitzer.

† For example, No. 106 fuzes as compared with No. 101 or 103 fuzes, or even No. 106 Mark III fuzes as compared with other patterns of this fuze.

contour of the fuze, on the position of the centre of gravity of the shell, and on the weight of the shell. As regards the latter, either the actual weight is stencilled on the shell, or the shell is specially marked; thus, on opposite sides of the head of the shell is stencilled a + or - number, which represents the number of units of weight, as used in the Range Table, by which the shell is above or below normal. For the 4.5-inch shells, the unit of weight is $\frac{1}{4}$ lb.; and typical markings are therefore:—

For shells between 34 lbs. 14 ozs. and 35 lbs. 2 ozs. inclusive	0
For shells below 34 lbs. 14 ozs. and down to 34 lbs. 10 ozs.	-1
For shells above 35 lbs. 2 ozs. and up to 35 lbs. 6 ozs.	+1

These are the weights of the shells issued fuzed; or if issued plugged, for a shell of the 2-inch gauge fitted with a No. 101 fuze and No. 2 gaine, and for a shell of the G.S. gauge fitted with a No. 44 fuze. If a shell of the 2-inch gauge is fitted with a No. 2 Mark II adapter and a No. 44 fuze, then an allowance of - 4 units must be made in the weight. If a shell fuzed with a No. 101 type is re-fitted with a No. 106 fuze, then an allowance of - 4 units must be made for the No. 106 Mark III fuze and - 2 units for other marks of this fuze; if a No. 103 fuze is replaced by a No. 106 fuze, then the corresponding allowances are - 3 and - 1 units respectively.

HIGH-EXPLOSIVE SHELLS.

High-explosive shells are arranged to detonate on impact. With full and complete detonation of the bursting-charge, the forged steel body is broken up into a large number of small fragments, which if the burst is above ground, are projected with high velocity in directions mainly transverse to the axis of the shell; there is also intense local damage to materiel; and the moral effect is considerable. If the burst is below ground, there is good crater or mine effect. When the detonation is only partial, the fragments are unduly large and there is more forward effect; and the other effects are appreciably less. With mere explosion, the effect is much less as regards the number of fragments and their spread, and the moral, crater and mine effects are not so pronounced.

The body of the shell is of forged steel. The base is integral with the walls; and the head and walls are usually in one piece, but in some cases the head is screwed into the body. In the nose of the shell is provided a screw-threaded socket to receive the fuze; the socket may be formed directly in the shell, or in a bush screwed into it. The driving band is pressed into an undercut groove in the walls of the shell near the base (p. 22).

For the bursting-charges the following high explosives are used:—Amatol, Lyddite (picric acid), and Trotyl (tri-nitro-toluene). Of these Amatol is by far the most important; it is of a mixture of ammonium nitrate and tri-nitro-toluene, the proportions usually employed being 40 or 80 parts of the former to 60 or 20 parts of the latter, respectively; these varieties are known as amatol 40/60 and amatol 80/20.

The explosives selected are all comparatively inert and safe substances, as they have to withstand the shock of discharge from the gun; they require a detonation in actual contact with them and well within their substance to ensure that they will detonate and not merely explode.

There are differences in the properties of these explosives. When detonated, although all three are extremely powerful, yet there is a slight advantage in favour of lyddite; amatol,

HIGH EXPLOSIVE SHELLS (PLATE I).

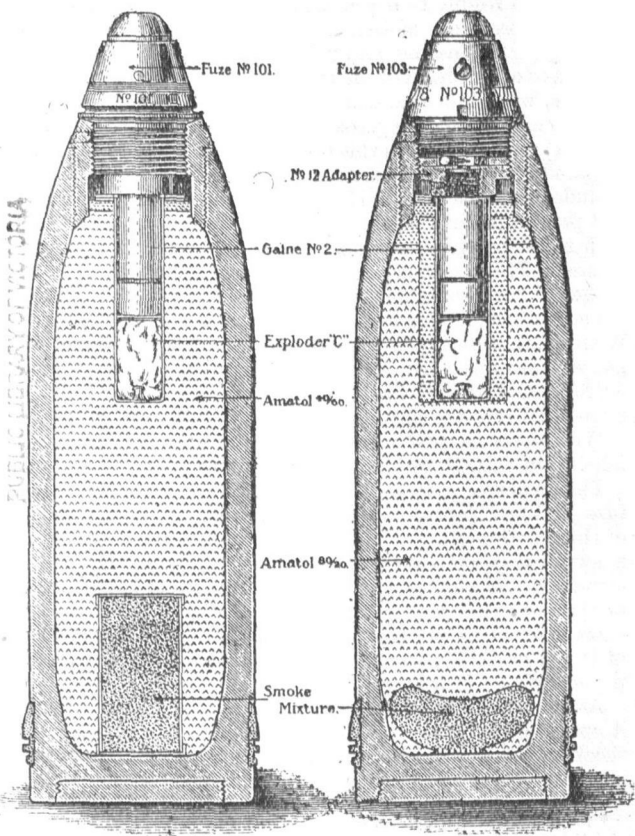

however, presents other and important advantages, and because of these it will be found that the majority of the shells are filled with this explosive. Amatol responds slightly less readily to detonation; it has also the disadvantage of absorbing moisture, which tends to reduce its capacity for detonating, and it is because of this that special care has to be observed in the sealing of the fuze-socket. Lyddite, when in actual contact with the metal of the shell, forms compounds dangerously sensitive to shocks and friction; and to obviate this danger, the interior of the shell is coated with a special varnish. For the same reason, lead is excluded from the paint of the shell and the metal of the fuze; and precautions are taken to prevent the contact of the acid with metal particles, rusty filings, and also chalk, lime and plaster. The fuze must only be removed when there is no danger of such contaminations.

The method of filling varies with the nature of the explosive. With amatol 40/60, lyddite and trotyl, the explosive is melted, poured into the shell, and allowed to set. When amatol 80/20 is used, the explosive in a powdered or pasty form, is introduced into the shell, and then compacted by pressure.

With either method, a cavity is formed in the centre of the filling; in this, is accommodated the exploder system.

The exploder system has an important function. The fuze of itself cannot start with certainty the detonation of the bursting-charge, but by interposing a small charge of a more easily detonated explosive,—trotyl or C.E. in fine crystals or powder,*—the detonating impulse is built up and at the same time transmitted to the centre of the bursting-charge, in which position it is most effective. The charge of trotyl or C.E. is enclosed in a cylindrical fabric bag or paper carton. It is then termed an exploder.

As the explosive used in the exploders is of a loose nature, it may, unless precautions are taken set back under the shock of firing and leave a gap beneath the fuze; such a gap acts as a barrier to the detonating impulse, either check-

* For a description of the exploder systems fitted to earlier patterns of lyddite-filled shells, reference should be made to the earlier editions of this pamphlet.

ing it entirely or reducing its efficiency. It is to obtain free transmission for this impulse that the following precautions as regards the exploders are observed:—the exploders must fill completely the space in the filling; the fuze or gaine must press tightly against the exploder adjacent to it; the exploders are fitted choked end downwards; they must be heavily compressed.

Exploders are made in various sizes. As the diameter remains the same in all cases, the important variable is the length. Originally the different exploders were defined by their nominal weights, 16 drs., 14 drs., 10 drs., &c.; later they are termed A, B, C, &c., exploders, these being in a decreasing order of size.

The exploders selected and their arrangement depends on the type of fuze with which the shell is fitted.

At present the H.E. shells of the 4.5-inch equipment are fitted in part with fuze No. 106 or 106 E (p. 56), in part with the graze fuzes Nos. 101, 101 E and 103 (p. 61) but without delay, and in part with the Nos. 83 or 88 time and percussion fuzes (p. 75).* The shells last mentioned are special for air-burst ranging.

Graze type fuzes are used in conjunction with a gaine (p. 66) which serves to produce the initial detonation. The gaine is fitted below the fuze and fills the upper part of the cavity in the filling; with No. 101 type fuzes the gaine is screwed directly into the fuze (p. 62), but with the No. 103 fuze it is carried by an adapter (No. 10 or 12) which screws into the fuze-socket (p. 78). In the space below the gaine is fitted a 14 drs. or "C" exploder, and to obtain the necessary compression a trotyl pellet is placed at the bottom of the cavity; alternatively, a single "A" exploder may be used. With some fillings having no exploder container the cavity is shorter; the "C" exploder is then sufficient.

When a time and percussion fuze is used, a similar arrangement of No. 2 gaine and exploder is employed, except that the gaine is supported in a No. 11 adapter (p. 79).

* For the future, the No. 88 fuze will be standard for these shells.

HIGH EXPLOSIVE SHELLS (PLATE II).

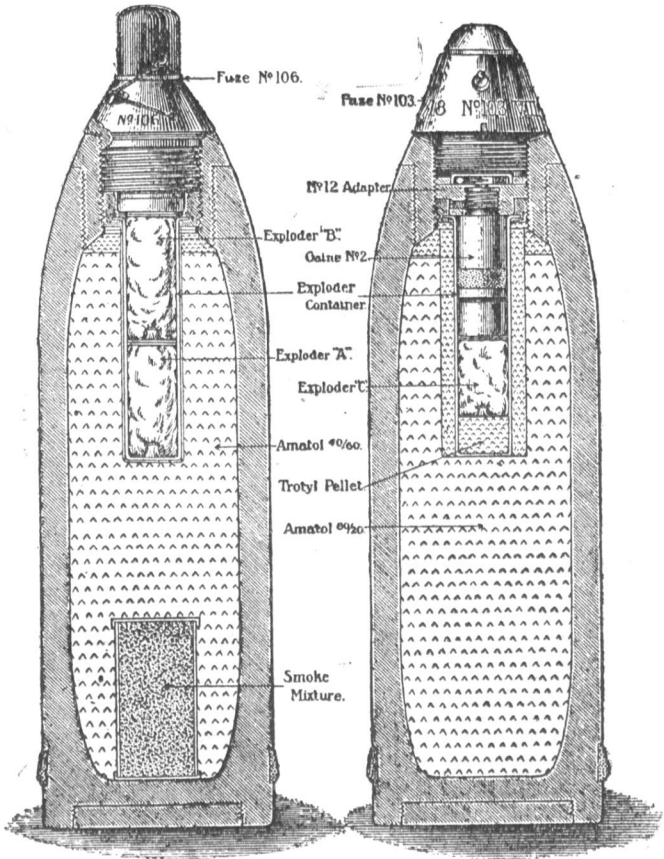

With fuze No. 106 a gaine is not required since this fuze is of a type which detonates when fired. The space occupied by the gaine is therefore filled with a second exploder which is here of the " B " pattern.

In some shells (more particularly those for use in hot climates) the exploder system is enclosed in a steel container screwed into the fuze-socket. The container seals the socket, preventing the entry of moisture which has a deadening effect on the detonating properties of the amatol; it also provides greater confinement for the exploder and so renders its detonation more effective; and to a minor extent it prevents the exploder from being contaminated with the exudation which sometimes occurs with shells containing trotyl in the fillings, see below. When an exploder container is used the lower exploder may consist of trotyl, charged directly into the container.

In some cases, more especially if the shell is to be fitted with an exploder container, the cavity in the filling is of greater diameter, and the additional space is filled with an annulus of cast or pressed trotyl either formed *in situ* or introduced as separate blocks. The trotyl responds to detonation more readily than amatol, so that this arrangement provides an easier carry-on of the detonating impulse from the exploder.

When crude trotyl* is used in the fillings of amatol and trotyl-filled shells, difficulties arise if a temperature of 80° F. is exceeded in storage. At these higher temperatures oily products exude from the filling, and by acting on the trotyl exploder reduce its efficiency or in extreme cases prevent it from functioning. It is important, therefore, that these shells should not be stored under conditions in which a temperature of 80° F. is exceeded; for example, they should not be exposed to the direct rays of the sun, and when on shipboard they must be stowed away from the boilers.

* Crude trotyl is now no longer employed.

HIGH EXPLOSIVE SHELLS (PLATE II)

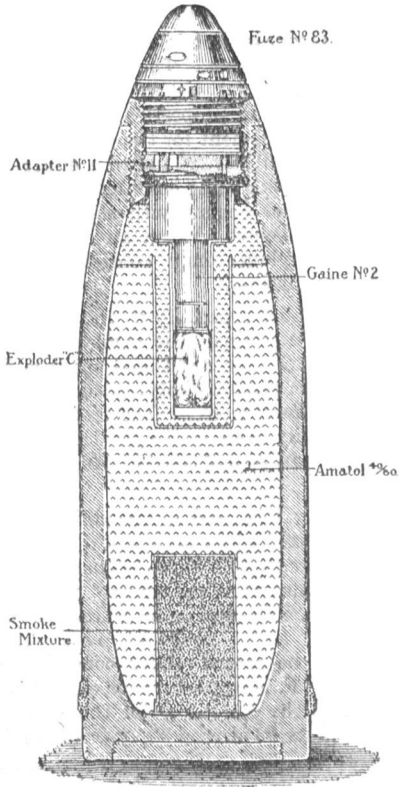

As it is impossible to observe this restriction in tropical climates, special fillings have to be provided. Thus, H.E. shells for these climates are filled with :—

- (1) Lyddite.
- (2) Pure trotyl.
- * (3) Amatol 40/60 or 80/20 made with pure trotyl, and fitted with C.E. exploders.
- † (4) Amatol 80/20 made with crude trotyl, and fitted with C.E. exploders.

With fillings (2), (3) and (4) the shell is identified by a special marking see p. 34. When lyddite is used as the filling, a special marking is unnecessary, as this explosive is not under any conditions subject to exudation.

The use of C.E. exploders is important. This explosive is not affected to a material extent by the exudation from crude trotyl. These exploders may therefore be fitted into shells in which exudation has occurred, the trotyl exploder being first removed, and the cavity freed from oily products. With lyddite-filled shells, C.E. exploders are unnecessary, and in fact if fitted would be dangerous, owing to the interaction that takes place between this explosive and lyddite.

When detonated, a H.E. shell has little incendiary effect, and the effect from the fumes is small. Detonation is indicated with lyddite and trotyl by black smoke and the absence of white or yellow streaks. With amatol, especially 80/20 the smoke effect is much less and of a bluish tinge; observation is therefore more difficult unless smoke-producing material is included in the filling.

Precautions have to be taken to guard against detonation of a H.E. shell in any other manner than by the action of the fuze. A steel base-plate (p. 32) is screwed or riveted into a turned-out recess in the base, to guard against the flash of the propellant passing through possible flaws in the metal of the shell. The walls of the cavity are coated with varnish to provide a smooth interior and obviate a premature burst at the shock of discharge by friction of the filling against the rough walls of the shell.

* Amatol 40/60 filling will not be continued.

† Under very severe conditions this filling cannot in all cases be relied on.

MARKINGS ON H.E. SHELLS.

H.E. shells are painted yellow to distinguish them from other natures of projectiles.

With amatol- or trotyl-filled shells the nature of the filling is indicated by a green band painted round the body of the shell and in the case of amatol by a fraction, for example 40/60, stencilled below it. On later shells this fraction will not be given if the filling is amatol 80/20; and in the case of trotyl-filled shells, which previously carried no marking other than the green band to denote the nature of the filling, these will have the word "trotyl" stencilled in black on the green band to obviate confusion with shells filled amatol 80/20.

Lyddite-filled shells do not bear the green band; the absence of this marking is therefore distinctive.

When filled, the usual red ring is painted round the head of the shell. The following is an important exception: amatol- or trotyl-filled shells having fillings suitable for use in hot climates, have instead of the complete red ring, either a red ring broken by yellow crosses or a ring of red crosses.

Shells for air-burst ranging, with which fuzes T. and P. Nos. 83 or 88 are to be used, have the letters "A R" stencilled on the body.

The design number of the method of filling is stencilled on the body of the shell.

If the shell is fitted with C.E. exploders, this is indicated by stencilling on the shell below the band,—Expr. C.E.

The following markings may be met with on the earlier issues. On the shoulder, the letter "G" to indicate that a gaine is fitted, and followed by a numerical indicating the pattern of the gaine, thus "G 2." Below the green band, a small green rectangle if a trotyl pellet is fitted at the bottom of the cavity; an open green rectangle, if the exploder cavity is surrounded with trotyl; and markings to indicate the nature and pattern of the exploder.

MARKINGS ON H.E. SHELLS.

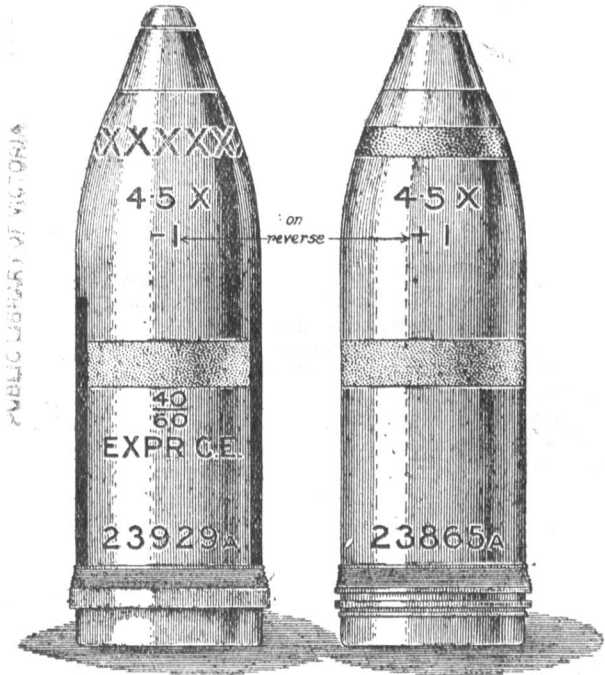

INCENDIARY SHELLS.

The incendiary shells used with the Q.F. 4.5-inch equipment are designed to set fire to buildings, dumps, and other inflammable targets; in dry weather they may also be used to set fire to grass, forming smoke screens of considerable value. The shells are arranged to be burst at a short distance from the objective, and the incendiary effect is obtained by the discharge of burning material from the mouth of the shell.

With the present equipment several different patterns of shells have been used. But all are similar to a shrapnel shell: the incendiary filling occupies the bullet space; there is an opening-charge in the base; a time and percussion fuze completes the head. And the action is the same:—at the burst, the head of the shell is blown off, and the incendiary material is projected from the mouth of the shell by the explosion of the opening-charge at the rear, which, however, has the additional duty of igniting the incendiary material.

In the earliest pattern (Mark I) the incendiary material is thermit, and is simply stemmed into the body. The tin cup and central tube are filled with an explosive specially selected on its ability to set fire to the thermit, which ignites with difficulty. Much heat is generated during the combustion of the thermit, and the final product—molten iron—is raised to an extremely high temperature. When the shell is burst the burning and molten material is projected as a shower from the mouth of the shell. With this type of shell it is important that the burst should take place in the air and at a short distance from the objective.

In a later pattern of shell (Mark II) the bulk filling of thermit is replaced by a number of short cylinders, the so-called stars, filled with incendiary composition; and for the opening charge a small charge of fine grain gunpowder is used. Each star has a central passage, and the stars are supported on perforated steel discs so that a continuous passage is provided between the fuze-socket and the opening charge in the base of the shell. The steel discs are spaced

SHELLS, Q.F., INCENDIARY, 4.5-INCH.
 MARK II. MARK III.

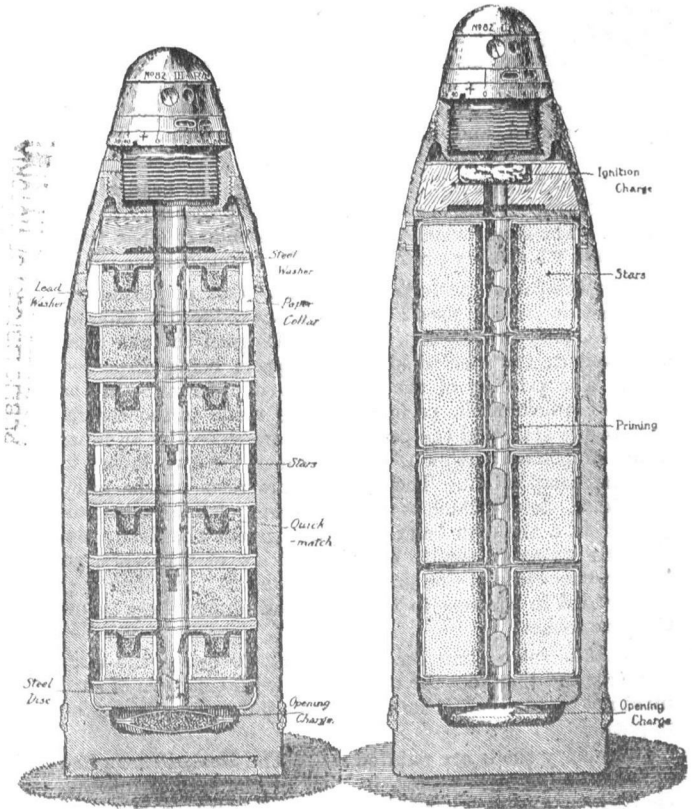

apart by short steel cylinders, which surround the stars and are of increasing thickness towards the base of the shell, paper cylinders to act as packing pieces being added where necessary. When the fuze is burst, the flash passes down the central passage and ignites the ends of quickmatch embedded in the priming of the stars and which project into the passage passing through them. To ensure that the stars are ignited before discharge, a delay pellet was fitted in the steel supporting disc at the base of the shell, so as to retard the explosion of the opening charge ; but in later shells this delay is omitted, and ignition of the stars is ensured by the use of an increased charge of gunpowder.

With the explosion of the opening-charge the head of the shell is blown off, and the flaming stars are projected from its mouth. The stars, which derive their incendiary effect from the flames which they produce, burn for a considerable time.

With the latest pattern (Mark III), stars of incendiary composition are still used ; but these are reduced in number to three, and, in addition, they are designed to take their own weight, the steel discs and supports being dispensed with. The priming of the stars is also different :—in the place of quickmatch, perforations are made in the central tube of the star, and the perforations are closed by an inner lining of primed shalloon, behind which are two layers of priming composition. The pile of stars rests on the usual steel disc, below which is a small charge of fine grain gunpowder in a shalloon bag ; and to augment the flash from the fuze so as to ensure certain ignition of the stars, an igniter, consisting of fine grain gunpowder in a shalloon bag, is provided in a recess in a wood block immediately below the fuze socket.

It takes some time for the priming to ignite the stars properly and therefore the fuze-setting with this type of shell must not be too long, otherwise the stars may be put out on impact.

Incendiary shells are painted red. The Mark I shells had their heads painted yellow, in view of the special opening charge, and the usual red ring was painted round the head

when this charge was inserted. Later shells are painted entirely red, and the red ring is represented by the space between two black rings; but the latter marking is now omitted. Formerly the letters INCDY (incendiary) were stencilled on the side of the shell. In all cases the design number of the method of filling,* the initials of the filling station and the date of filling are stencilled on the body.

The shells are issued fuzed. The fuzes fitted are either T. & P., No. 82 (p. 72), or T. & P., No. 83 R, Marks I and II (p. 75), or T. & P., No. 83, Marks III-V (p. 75).

Incendiary shells must be stored and transported separately from other ammunition; an exception may be made in the case of smoke shell. (See footnote, p. 40.)

* For the Mark I shells the design number is 3333; for the Mark II shells, 25186; for the Mark III shells, 27253.

SMOKE SHELLS.

Smoke shells are used for the production of smoke screens. When the shell is burst, the filling, specially selected for the purpose, is ignited, producing dense white smoke which, under favourable conditions, hangs close to the ground for a considerable time (1 to 5 minutes). For the purpose of opening the shell and igniting its contents, a small charge of H.E. is provided in a container fitted into or constituting the head of the shell.

The smoke effect is influenced by the atmospheric conditions prevailing. On a warm sunny day it has been found that one round will cover about 80 yards of front, and that a screen so formed can be maintained by one round every 10 to 15 minutes. The steel shells, which contain a larger charge of smoke-producing material, may give a slightly more dense smoke cloud; but approximately the same rate of fire is required for the steel and cast-iron shells.*

To obtain the maximum screening effect the burst must take place actually on the ground; a percussion fuze is therefore necessary. The fuze selected must be as nearly as possible instantaneous in its action so that the burst will take place immediately on impact; if the burst is smothered, the value of the screening effect is appreciably reduced. Fuzes No. 44 (p. 53) or Nos. 106 or 106 E (p. 56) are used with these shells.

To distinguish these shells the bodies are painted light green. The nature of the filling is indicated by the letters PHOS (phosphorus) stencilled on the shoulder; and the method of the filling, by the design number stencilled above the driving band. The usual red ring is painted round the head when the bursting charge is inserted, and above this is a brown ring if the shell has a cast-iron body.

Because of the nature of the filling, smoke shells must be stored and transported separately from other ammunition.†

* The cast-iron shells are specially marked; see later.

† They may, however, be stored with incendiary shells.

When on ship they must be stowed as deck cargo. Leakage of the filling should be looked for, and, if detected, the shells which are leaking should be moved away if possible from other ammunition and any combustible material, immersed in or copiously drenched with water, and the failure immediately reported.

As phosphorus melts at about 111° F., it is desirable that this ammunition should be kept as cool as possible; it should not be exposed to the direct rays of the sun, and a round should not be allowed to remain in a hot gun longer than is necessary.

Revised edition of the Manual of the Ordnance Department, 1917, page 100.

CHEMICAL SHELLS.

These shells are intended for the attack of personnel. The bodies of the shells are filled with liquids which at the burst are converted into toxic or noxious gases or vapours, and the advantage of the shells lies in the comparatively long time over which the effect from the gas or vapour persists, also on the ability of the gas, &c., to penetrate dug-outs, trenches and other sheltered positions on which a direct hit is impossible.

The effect depends on the nature of the filling, and on the atmospheric conditions prevailing. Thus, with certain fillings the gas cloud is very penetrant* ; with others the effect lasts for a comparatively long time ; while in other cases the effect is only temporary, and there is but little power of penetration.* The tactical use of the shells is governed largely by these properties of the fillings, and it is convenient to classify them as follows :—penetrant, persistent, non-persistent.

As regards the atmospheric conditions, it is found that a high wind causes rapid dissipation of the gas cloud, although in the shelter of woods and villages the effect of the wind is considerably reduced and the gas may remain potent for lengthy periods. Other conditions unfavourable to the persistence of the effect are a hot sun, heavy rain and a temperature below freezing point. The gases and vapours are heavy, and therefore tend to lie close to the ground and to remain in shell-holes, trenches, dug-outs and other sheltered places.

As a rough approximation it may be taken that the effect lasts from a few minutes to several days, according to the nature of the filling and the atmospheric conditions.

The shells have forged steel or cast-iron bodies. The fillings, for which a variety of liquids are used, are introduced through an opening in the side of the body, afterwards closed by a steel plug tightly driven in ; the mouth of the shell is closed by a container in which the fuze is fitted. In the container is a small charge of high explosive, sufficient to break up the shell and scatter its contents.

* That is, as regards the gas-mask.

As the burst must take place actually on the ground, a percussion fuze is necessary; in addition, the fuze selected must be instantaneous in its action as a smothered burst is of little value. Fuzes Nos. 106 or 106 E (p. 56) have been found the most suitable.

To distinguish these shells the bodies are painted light grey. A variety of liquids are used for the fillings. These liquids are of secret composition, and are known by symbols and identified by coloured bands painted round the bodies of the shells. At present, the following fillings are being used:—

- N.C. (penetrant), identified by white, red, white bands.
- C.G. (non-persistent), identified by red, white, white bands.
- B.B. (persistent), identified by four red bands.
- S.K. (persistent), identified by the absence of marking.
- K.S.K. (persistent), identified by letters HVY.*

In addition there is now stamped on the head of the shell letters which indicate the colour of the bands, and which are arranged in a vertical column and in the same order as the bands themselves. Thus, for N.C. the stamping is W (white), R (red), W (white); for S.K., NB (no band). This marking is a permanent record of the nature of the filling, and is always available should the coloured bands be obliterated.

In all cases the design number of the method of filling is stencilled on the side of the shell, and the usual red ring is painted round the head of the shell when the bursting-charge is inserted. A brown ring below the red ring indicates that the shell has a cast-iron body.

Chemical shells must be stored and transported separately from other ammunition. Leakage at the joint of the container and at the filling hole should be looked for, and if detected the shell should be buried deep in the ground and in such a position as not to contaminate ponds and streams. Men handling the shells must be provided with anti-gas helmets of the large "box-respirator" type, to be used if leakage of the filling is suspected; and in the case of B.B., the men must be provided with special clothing.

* These shells are filled with pure S.K., and the marking indicates that as compared with S.K. shells, these are heavy in weight.

PACKING.

For transport and storage the shells and cartridges are now issued separately. The shells are packed in wood boxes holding two or three; the cartridges, each in a tin cylinder, in a wood box holding ten, or in a canvas carrier holding five. The carrier consists of an octagonal bag of hessian canvas strengthened along the sides by eight wood laths, and provided with a suitably shaped bottom piece and a loose lid; the cartridge cylinders are packed one on top of the other, and the mouth of the bag is closed by the lid held in place by constricting the bag by means of a cord run through its edge.

Formerly the ammunition was packed as complete rounds in wood boxes. These contained two shells, and the necessary number of cartridges and fuzes.

All empty packages should be returned at the first opportunity. Before return, the lids should be carefully secured to the packages.

MARKINGS ON PACKAGES.

Boxes are stained brown except where otherwise stated.

Stencillings and other paint markings on the packages give full information as to their contents. Typical schemes of markings are shown on the sketches on p. 46. In particular, attention is drawn to the following:—

The number of shells in the box is marked on the lid and sides, thus:—2 SHELL or 3 SHELL; the number of cartridges in a box, thus:—10 CARTGES; the number of cartridges in the carrier, thus:—5 CARTGES.

Black stripes along the side edges of the sides of the box indicate that the shells are fitted with the new pattern driving band (p. 23).

On the lid and ends of the box a symbol in red and resembling a mushroom indicates that the shells are fitted with No. 106 fuzes; an inverted truncated cone in red, that fuzes No. 44 are fitted; a blue disc, that the shells are fitted with Nos. 100, 101, 102, or 103 fuzes *arranged for delay-action*; a black hollow diamond, that No. 101 E fuzes *without delay* are fitted; a blue disc inside a blue hollow diamond, that fuzes No. 101 E *with delay* are fitted.

H.E.—On the sides a fraction—for example, 40/60—indicating the proportion of the constituents in the amatol—if this is the filling used. If the shells are filled with lyddite, the letters LYD are stencilled on the ends of the box.

On the ends, two red crosses if the amatol filling is adapted for use in hot climates.

The design number of the method of filling is stencilled on the sides of the box.

The letters A R on the sides and ends indicate that the shells are for air ranging.

Chemical.—The boxes are painted light grey; across the lid and ends, coloured bands corresponding to the bands painted round the bodies of the shells; on the sides, the design number of the method of filling.

MARKINGS ON PACKAGES.

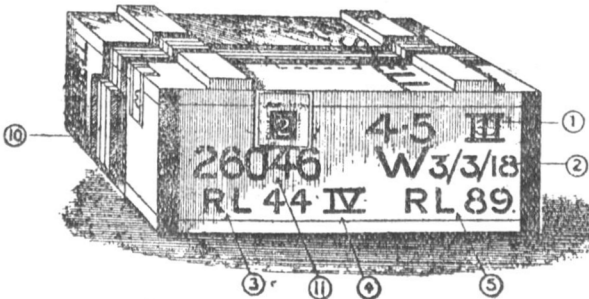
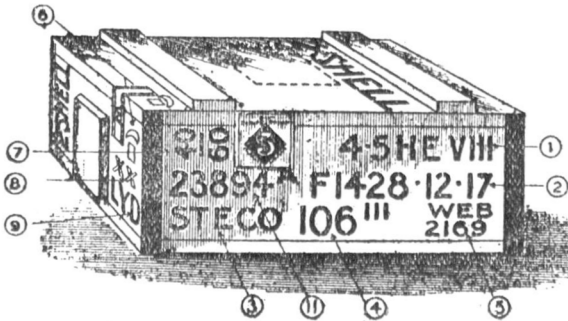

- (1) Mark of shell.
- (2) Filling station, and date of filling.
- (3) Manufacturer of empty fuze.
- (4) Pattern of fuze.
- (5) Filler of fuze.
- (6) Fuze symbol.
- (7) If shells are filled amatol 40/60.
- (8) If amatol filling is suitable for use in hot climates.
- (9) If shells are filled lyddite.
- (10) Colour bands agreeing with those round bodies of chemical shells.
- (11) Design number of the method of filling.
- (12) Lot letter and number of propellant.
- (13) Ballistic group of propellant.

Smoke.—The boxes are painted light green ; on the ends, the letters PHOS, to indicate the nature of the filling ; on the sides, the design number of the method for filling ; on the ends, the words DECK CARGO, as an instruction when the ammunition is being stowed on board ship.

Incendiary.—The boxes are painted red ; the design number of the method of filling is stencilled on the sides of the box.

Star.—A six-pointed star is stencilled on each end of the box.

Cartridge packages.—On the lid or sides, the lot letter and number of the propellant ; the size of the propellant ; and a letter or letters which represent the nature of the propellant and which are :—C for cordite R.D.B., D for cordite M.D., B for ballistite, and N.C.T. for nitro-cellulose powder. If, however, the propellant belongs to a lot which has been grouped ballistically (p. 17), then these letters are replaced by the ballistic group marking enclosed in a rectangle of the same colour as the letters, thus, C. 12.

On all packages there is pasted the group and division label and the Government explosive label, or the label which is a combination of these ; these labels serve as a guide for segregating the ammunition during transport or storage. And on the joint of the lid or the securing means of the package is secured the label of the station at which the package was completed.

GENERAL NOTES ON FUZES.

The bursting-charge of a shell is ignited or detonated by means of a fuze designed to act at any particular instant during flight, or upon or after impact or graze. These functions correspond to the time fuzes and to the percussion fuzes respectively, or they may be found together as in a time and percussion fuze, the so-called T. & P. fuze. Percussion and T. & P. fuzes are used with the Q.F. 4.5-inch howitzer equipment. In the following notes the percussion fuzes, and T. & P. fuzes are treated separately.

Fuzes, when not fixed in the shell, are issued packed in tin cylinders. The lid of the cylinder is sealed by a soldered strip or by a shellaced tape band; and it is important, in order to prevent deterioration and consequent blinds or prematures, that the strip or band should not be removed until the fuze is to be fitted in the shell.

Fuzes are screw-threaded externally for a part of their length to engage the screw thread of the fuze socket. After screwing into the shell the fuze must be further secured, since the vibration to which the round is subjected when travelling, may cause the fuze to unscrew; also, a time fuze, if not held, may rotate bodily in the fuze socket when an attempt is made to set it. For fixing the fuze, either a grub screw is provided or a lip turned on the fuze is punched into recesses cut in the fuze socket; or, in the case of cast-iron fuzes, a steel washer is fitted below the flange of the fuze, and punched into the recesses of the fuze socket and into slots cut in the fuze body; or, in exceptional cases, the metal of the shell is punched into the slots cut in the cast-iron fuze body.* The last-mentioned method is applicable only at filling factories, as special precautions have to be taken.

All fuzes are stamped with their distinguishing number and mark, the maker's initials, date and lot number; and the same information is given on a label on the lid of the box.

Fuzes must not be broken down or tampered with to satisfy curiosity as to their internal construction. The descriptions in the notes which follow, give all information that is necessary. To fire a re-assembled fuze is most reprehensible; a premature burst will probably be the result.

* C.I. fuzes obsolete for future manufacture.

PERCUSSION FUZES.

Percussion fuzes are of two main types, viz., direct-action fuzes and graze fuzes. The latter are further subdivided into delay and non-delay fuzes.

Direct-action fuzes and graze fuzes differ fundamentally in their construction and in their method of operation. These differences have an important influence on the effect obtained from the shell.

Direct-action fuzes are instantaneous in their action, the burst taking place immediately on impact, and the effect is entirely above ground. These fuzes are therefore with H.E. shell of primary use in those situations in which concussion and splinter effect is desired—for example, against personnel in the open and wire entanglements, and for defensive barrages and counter-battery work. For smoke and chemical shell they are now almost exclusively used, as the effect from these is entirely above ground; a fuze which allowed the shell to bury would render the burst of little value.

To obtain this instantaneous action, the fuze is arranged so that, when prepared for firing, an operative part is exposed, and the fuze functions when this part makes violent impact with the ground, or with an obstruction offering sufficient resistance. With the No. 106 fuze used with the present equipment the wire of entanglements offers a resistance sufficient to cause the fuze to act.

With direct-action fuzes certainty of action depends on the angle of descent and on the design of the operative part of the fuze. Thus, the No. 106 fuze will not act with certainty at angles below 6° , and the No. 44 fuze at angles slightly greater. For angles below these a graze fuze may be used, because of the greater certainty in its action; but it is still possible to use a direct-action fuze if a proportion of blinds can be accepted.

In a graze fuze the operative parts are entirely enclosed, and the fuze, instead of relying on a blow delivered to an actual part of it, depends for its action on the check to the forward velocity of the shell that occurs on impact or graze.

For this purpose a pellet is mounted inside the fuze in such a manner that on graze or impact the pellet, owing to its inertia, flies forward, causing a needle to strike a detonator. Special arrangements are provided to guard against premature action in transport, in handling and in loading; on discharge, while the shell is in the bore; and during flight, before it strikes or grazes.

The percussion mechanisms of T. & P. fuzes are of the graze type.

A graze fuze will act correctly at angles of impact much smaller than those at which a direct-action fuze can be used with certainty, and it is for this reason that at angles of descent below about 6° that a graze fuze presents advantages, and fewer blinks are to be expected. But there is another and important advantage. The operative parts of the fuze are entirely enclosed, and no manipulation of the fuze is necessary to bring the fuze into a condition for loading. These features, on the one hand, facilitate the service of the gun, and, on the other, give greater safety in handling and in loading.

As at present designed, graze fuzes present this difficulty: by themselves they are not capable of effecting the detonation of high-explosive bursting-charges, although adequate with shells containing gunpowder bursters which require simply to be ignited. Therefore with H.E. and similar shells a graze fuze must be used in conjunction with a gaine. In this the flash from the fuze is converted into a suitable initial detonation. With the direct-action fuzes Nos. 44 and 106 a gaine is unnecessary since the fuze contains a charge of high explosive which is arranged to be detonated when the fuze acts.

As has been explained previously, a direct-action fuze is instantaneous in its action. A graze fuze is, however, distinctly slower; it takes an appreciable interval of time for the pellet to move forward and fire the detonator. In some cases the delay is intentionally increased by a suitable filling of the fuze or the gaine.

Graze fuzes with this added delay are known as "delay" fuzes; without the delay, as "non-delay" fuzes. The term "non-delay" is used only by way of contrast with the delay given by "delay" fuzes. Even with "non-delay" fuzes there is, as explained above, an appreciable delay in their action, certainly as compared with fuzes of the direct-action type, the so-called "instantaneous" fuzes.

The use of a graze fuze is largely determined by the delay. Thus non-delay fuzes are used in high-explosive shells of the present equipments, for the attack of barricades, walls, breastworks, light cover and other targets, against which a burst immediately after penetration is most effective. The blast and splinter effects are less than those obtained with instantaneous fuzes, and although these fuzes can be used for the destruction of wire entanglements, their use is wasteful.

The effect from a delay fuze depends on the angle of descent, the nature of the ground and the remaining velocity of the shell. At angles less than 8° , the shell ricochets, and the burst takes place at a short distance from the point of impact; under these conditions shells so fuzed are suitable for the attack of trenches known to be manned, and for barrage purposes. But the main use of delay fuzes with high-explosive shells of the present equipment is for below-ground effect. If the striking velocity is high and the ground suitable, the burst may take place some feet from the point of impact; such bursts are effective against deep overhead cover, dug-outs and magazines. But in other cases, especially when the lower charges are used, the shell does not bury so deeply, but gives good crater effect, superior to that obtained with a non-delay fuze.

Since failure of the fuze has been found in some cases to be the cause of a premature burst of the shell while it is travelling along the bore, special provision is now made in the fuze to guard against this; for example, the fuze is fitted with a shutter which blocks the passage between the detonator and the magazine and which is intended to remain closed until the shell has left the bore. The delay used with delay fuzes serves the same purpose, since if the fuze should

fail, the burst is delayed and takes place only when the shell is well clear of the howitzer.

To assist identification, the boxes in which percussion fuzes or the fuzed rounds are packed, are provided with symbols which are distinctive for each pattern of fuze. The symbols will be referred to in the detailed description of the fuzes, which follows.

FUZE, PERCUSSION, DIRECT-ACTION, No. 44.

This fuze is now only issued with the smoke shells of the 4.5-inch equipment, but earlier issues of chemical and high-explosive shells fitted with this fuze may be met with.

When issued separately each fuze is packed in a sealed tin cylinder, which may be sufficiently large to take a 14 drs. or upper exploder and an adapter, to enable the fuze to be used if necessary in a shell prepared to take a graze fuze of the No. 101 type (p. 61). The cylinders are packed in wood boxes, which usually hold 50 fuzes, and on each end of the box is stencilled a symbol in red and resembling an inverted truncated cone, and which is distinctive for this pattern of the fuze. This symbol is also used on the packages containing shells fitted with this fuze.

The body of the fuze is screw-threaded to the G.S. gauge, and over the head of the fuze is fitted a cap. The cap is either provided with two securing pins, and the safety-pin is secured to the cap by a becket; or, as in later fuzes, a single securing-pin is used, and through this the safety-pin is threaded. Immediately before loading, the cap which protects the operative part of the fuze is removed. The procedure is slightly different in the two cases. In the first case the securing-pins are withdrawn, the cap turned slightly to release it, then removed from the head of the fuze and given a steady pull to withdraw the safety-pin, the pull being in the direction of the length of the pin. With the later design of cap, the securing-pin together with the safety-pin, are removed by means of the becket attached to it; the cap is then turned slightly, when it can be lifted off.

Immediately below the cap is the needle, supported by a copper disc over the detonator, and below this is a passage filled with C.E., leading to the magazine. This passage is broken in its length by a pivoted shutter kept in position by a spring, and, during transit, by the safety-pin. Before loading, the safety-pin is withdrawn. On firing, the spin of the shell tends to cause the shutter to move into the open position in which an opening in the shutter and filled with C.E. is opposite

FUZE, PERCUSSION, DIRECT ACTION, No. 44.

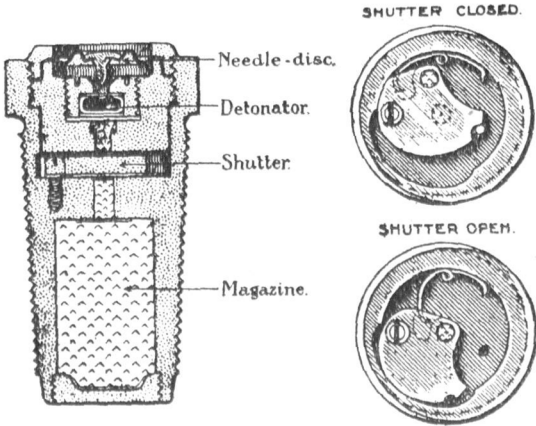

MARKS I-IV.

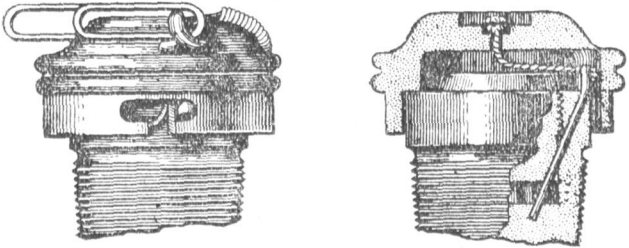

MARK V.

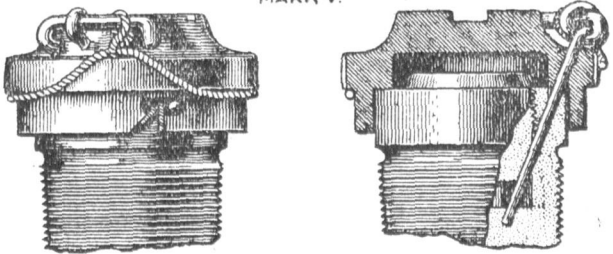

the passage leading to the magazine ; but while the shell is in the gun—that is, during the period of acceleration—the shutter sets down on to its supporting platform and the resulting frictional resistance prevents any movement. The shutter therefore does not open until the shell has left the bore, and consequently acts as a barrier to the detonating impulse, should the detonator fail under the shock of discharge.

On impact the needle disc is driven in, the needle fires the detonator, and the detonating impulse travels down the C.E. in the passage and the shutter to the C.E. pellet which constitutes the magazine ; and this is then detonated.

For fixing the fuze in the shell, a slot or square recess is provided in the cap, to be used in conjunction with the projection at the side of the No. 5 or No. 19 keys.* When fixing, care should be taken that the fuze is screwed right down with the bottom of the cap in line with the bush in the shell, and that the securing-pins do not foul the bush.

To remove the fuze, the same part of the key may be used. But if greater leverage is required the projection on the small radius of the keys is inserted in the slot of the cap, the securing-pins, or, in the case of the Mark V and later fuzes, the securing-pin and safety-pin being first removed. The securing-pins, or the securing-pin and safety-pin, must be replaced after the fuze has been removed, or if the attempt to remove it is abandoned.

* According to the latest procedure the fuze must not be screwed directly into the shell. The adapter, if fitted in the shell, is to be removed, the fuze screwed into it, and the combined fuze and adapter screwed into the shell.

FUZE, PERCUSSION, DIRECT ACTION, No. 106.

This fuze is of the direct-action type. It is used with a proportion of the H.E. shells, and with the chemical and smoke shells. Its use is determined by its ability to function immediately on impact, the maximum effect from these shells being obtained if the bursts take place entirely above ground. The sensitiveness of the fuze is such that it will act on striking the wire of entanglements.

When issued separately, each fuze is packed in a sealed tin cylinder, which also contains a trotyl exploder for fitting in the space normally occupied by the gaine. The cylinders are packed in wood boxes, which, in order to assist identification, have stencilled prominently on them a symbol in red and resembling an upright mushroom.

The Mark III pattern of fuze is usually employed with this ammunition; this fuze has a cast-iron body.* Other patterns have bodies of brass.

The lower part of the body is screw-threaded to the 2-inch gauge. The upper part continues the general lines of the shell, and is provided on opposite sides with holes to take either a tommy-bar or keys, Nos. 16 or 53 when the fuze is to be fixed or removed from the shell. Above the screw-threaded portion of the body is formed a flange to engage the seating of the fuze-socket, and in the edge of the flange, notches are cut if the fuze has a cast-iron body; into these notches the securing washer is punched when the fuze is to be fixed in the shell. If the fuze has a brass body, a lip is formed immediately above the flange; by punching this lip into slots cut in the fuze-socket, the fuze is secured in the shell.

In the upper part of the body is fitted the percussion-mechanism, consisting of a hammer with its safety-devices, namely, supporting collar, brass or copper tape, shearing wire and guide pin. With certain fuzes, these parts are carried

* No more cast-iron bodies will be manufactured.

FUZE, PERCUSSION, DIRECT ACTION, No. 106, MARK III.

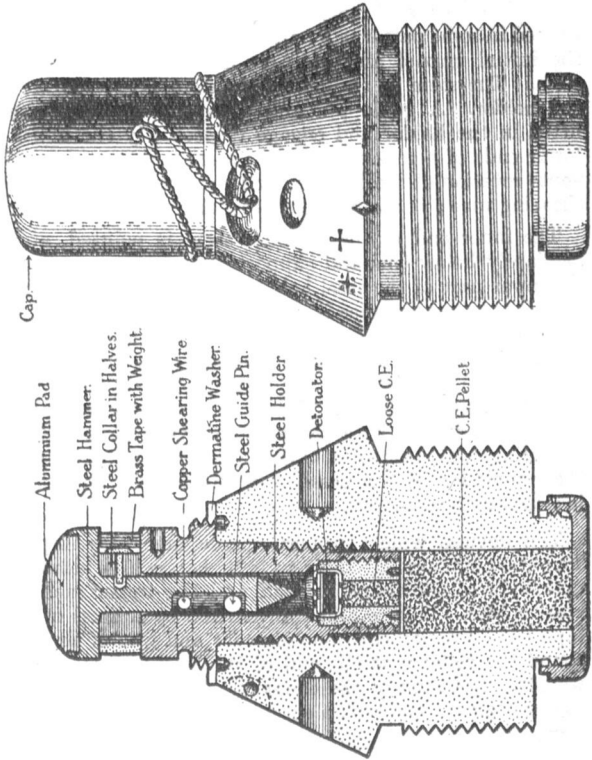

by a steel holder which screws into the upper part of a passage bored through the body ; in others having brass bodies, they are fitted directly in the body.

The hammer is of mushroom shape with a rounded head, formed in some patterns by an aluminium pad which receives the initial impact and obviates distortion of the hammer stem. The stem of the hammer enters a passage bored in the holder. A guide pin and a copper shearing wire are fitted in the holder and engage respectively the upper and lower ends of a recess cut in the stem. The guide pin prevents rotation of the hammer and consequent damage to the shearing wire ; it also prevents withdrawal of the hammer.

The inner end of the hammer stem is pointed, and immediately below this and supported in a plug screwed into the lower part of the steel holder is the detonator. In some later issues, a brass disc is, as a refinement for safety, interposed between the end of the stem and the detonator * ; the disc is of a strength sufficient to support the stem and prevent firing of the detonator, if the former should fracture under the shock of discharge. Below the detonator and communicating with it by a passage filled with loose C.E. is the magazine consisting of a C.E. pellet which completely fills the remainder of the passage in the body. The magazine is closed by a screw cap.

The devices which support the hammer are important. The steel supporting collar split in halves fits between the underside of the hammer head and the upper face of the steel holder. It is retained in position by a brass or copper tape passed underneath one segment and wound three times round the collar ; at the end of the tape is a brass or lead weight. Rotation of the collar is prevented by a pin fitted to one segment and which enters a hole bored in the stem.

To protect the hammer, tape, &c., during transport and until the moment of loading, a cup-shaped steel cap is screwed

* Fuzes with this brass disc have the letter " D " added after the mark of the numeral, thus No. 100 Mark IID.

on to the upper part of the holder. A dermatine washer between the cap and the body seals the joint and prevents the entry of moisture which might lead to deterioration of the detonator. The cap is secured either by a whipcord becket passed through eyes as shown, or by a thin steel wire which is threaded through the eyes, and the ends then twisted together and secured by a lead plug forced into a hole provided for it in the body. The eyes are positioned so that the becket or wire prevents unscrewing of the cap. When the wire is used, the cap is released by giving it a sharp twist to cut the wire.

When travelling, the vibration may cause the cap to unscrew; travelled rounds should therefore be inspected frequently. If the cap has become detached, the round must not be fired, but treated as if in a dangerous condition; it should be handled carefully, and returned for special examination. And the same action should be taken if the wire or seal has been inadvertently broken.*

Immediately before loading, the cap is removed. Should the dermatine washer be displaced, it must be removed also. The tape and the ends of the shearing wire must not be interfered with; the ends of the wire project through the side of the holder or body, a groove immediately above the dermatine washer being provided to receive the ends which are bent over. As a precaution the ends should be looked for; if the shearing wire is missing, the fuze is in a dangerous condition, and must not be fired since the hammer would be forced in during flight by the positive pressure on its head due to the translatory motion of the shell.

On firing, the acceleration of the shell causes the hammer to set back relatively to the fuze and to sit hard on the segments of the steel collar which support it. In addition the weight at the outer end of the tape being of slightly greater height than the segments, is gripped by the hammer,

* See amendment, page 14, Pamphlet No. 4, Regulations for A.O.S., Part II.

and therefore arming of the fuze by the release of the tape and segments cannot take place until acceleration has ceased, that is, until the shell leaves the bore.

After discharge, the hammer releases its grip, and the spin of the shell causes the tape and segments to fly off; the hammer is then supported only by its shearing wire.

On impact the hammer is driven in, shearing the copper wire; the detonator is fired, detonating the loose C.E. below it, and this in turn detonates the C.E. magazine.

FUZE, PERCUSSION, DIRECT ACTION, No. 106 E.

This fuze is an alternative to the No. 106 and will eventually replace it. It is identical with the latter fuze except that a shutter similar to and having the same functions as that used in the No. 44 fuze, is interposed in the passage connecting the detonator and magazine.

FUZE, PERCUSSION, No. 101 E.

This fuze is used with a proportion of the H.E. shells of the 4.5-inch equipment. It comprises a body, a cap, and an adapter in which is fitted a shutter. The lower part of the body is screw-threaded to the 2-inch gauge; the contour of the upper part continues the general lines of the shell. The body is bored out axially to provide a chamber for the graze pellet, which is prevented from moving forward by a centrifugal bolt, itself locked by a detent pressed upwards by a spring.

The shock of discharge causes the detent to set back, compressing its spring; and the detent pin thrown outwards by the spin of the shell (see sketch on page 64), catches under the shoulder of its recess and prevents return of the detent to its original position. The rotation of the shell then causes the centrifugal bolt to move outwards, clearing the graze pellet. The latter is restrained from moving forward during flight by a creep spring interposed between the cap and the pellet.

On graze or impact the pellet flies forward, compressing its creep spring, and the needle in the cap fires the detonator. The flash passes through a passage provided in the graze pellet, and fires the gaine which is screwed into the adapter, itself screwed into a recess in the base of the fuze.

In the adapter is fitted the shutter which prevents the fuze acting should its detonator fail at the shock of discharge. The shutter consists of a block fitted to slide in a slot in its holder and normally held in a closed position masking the flash-hole to the gaine, by a coil spring and a detent, oppositely disposed with respect to the shutter. Under the spin of the shell, the shutter, owing to its eccentric position, moves outwards and un.masks the flash-hole; this movement is, however, resisted during the time the shell is passing along the bore—that is, while the shell is accelerating—by the frictional resistance arising from the set-back of the shutter on to its supporting platform.

FUZE, PERCUSSION, No. 101.

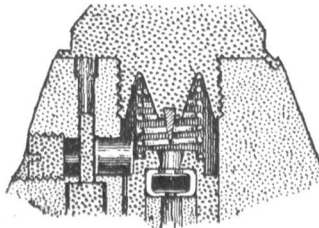
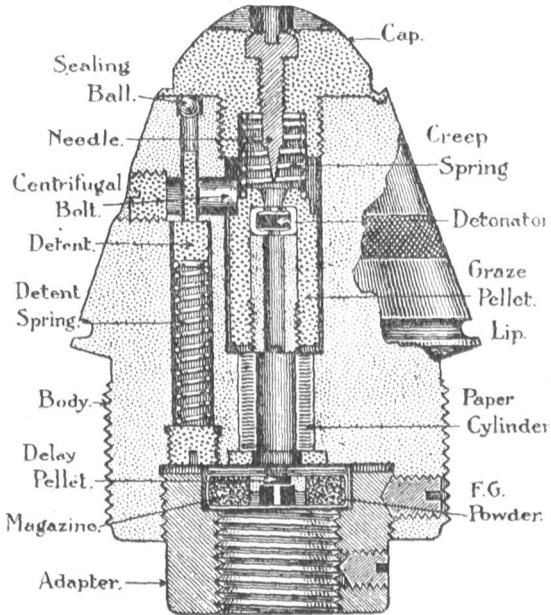

SHOWING SPUN IN NEEDLE

SHUTTER CLOSED.

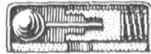

SHUTTER OPEN

SHUTTER OF
No 101 E. FUZE.

It is therefore during flight that the shutter moves outwards ; and at the same time the tail of the detent is released from its recess in the shutter, moves to one side and prevents return movement.

The fuze is of the delay or non-delay type according as the gaine with which it is fitted, is provided or not with delay. Delay fuzes have their caps painted blue.

To distinguish the No. 101 E fuzes, the boxes in which they are packed, are marked with a black skeleton diamond if without delay, or with a blue diamond enclosing a blue disc, if with delay.

Fuze, Graze, No. 100 was the original fuze of this series. It had no magazine or shutter, and its action was different. When the graze pellet moved forward its tail was withdrawn from and released a cocked pellet arranged transversely in the body, see sketch (p. 64).

Fuze, Percussion, No. 101 is an earlier pattern of the No. 101 E fuze. It is not provided with a shutter, but in its place may be fitted a magazine in which may be incorporated the delay. Certain of these fuzes were fitted with a needle of a different pattern, and subsequently these needles had to be tested ; if found to be satisfactory the caps of the fuzes were painted green, or if with delay, partly green and partly blue.

Fuze, Percussion, No. 102 is the No. 100 fuze converted to the No. 101 pattern by removing the cocked pellet and fitting the detonator in the graze pellet.

FUZE, GRAZE, NO. 100, MARK I.

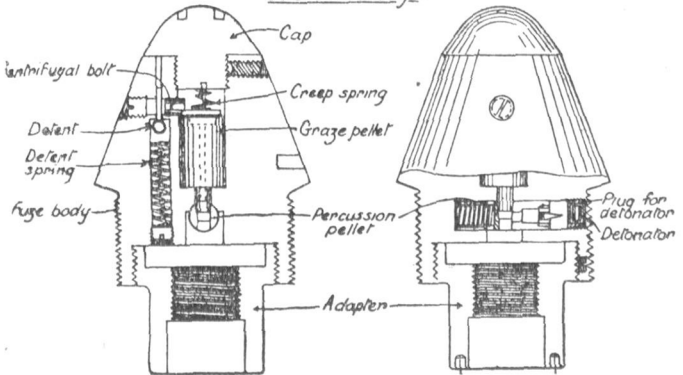
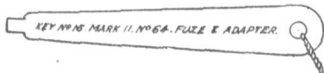
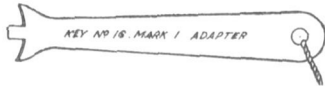
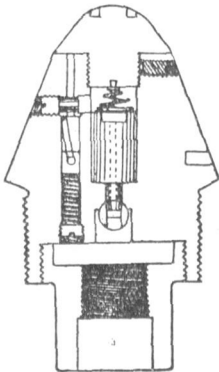
Before discharge.*During flight.*

FUZE, PERCUSSION, No. 103.

This fuze is used in a proportion of the H.E. shells, alternatively with the No. 101 type fuzes. It is similar to the Nos. 101 and 102 fuzes except that an adapter is not provided; and the screw-threaded portion of the body is reduced in depth; the gaine is then carried by an adapter which screws into fuze-socket below the fuze. For this purpose, adapter Nos. 10 and 12 are used; the latter is provided with a shutter similar to that used with the No. 101 E fuze.

These fuzes may have either brass or cast-iron bodies. The cast-iron bodies are given a suitable rust-proofing treatment. This does not give an absolute protection, particularly if the surface has been damaged by rough usage. Every care should therefore be taken that the fuzes are kept as dry as possible.

GAINES, Nos. 2 AND 4.

When a fuze of the No. 100 type or a time fuze is used in a shell containing a high-explosive bursting-charge, a gaine is necessary, see p. 67. The gaine converts the flash from the fuze into a detonation necessary for the send-off of the high-explosive charge.

The No. 2 gaine consists of a steel tube or sleeve. The upper end is threaded to screw into an adapter, which in turn screws into a recess in the base of the fuze. When the fuze is fixed in the shell, the gaine lies below it in the cavity formed in the filling (p. 27).

In the No. 4 gaine, the adapter is formed in one piece with the gaine-body.*

Perforated powder pellets in the upper part of the gaine are ignited by the flash from the fuze; and the strengthened flash then passes through the small opening in the diaphragm, and ignites the explosive in the detonator. The fulminate of mercury, when ignited, immediately detonates, and it is here that the initial detonation is obtained, the change-over from burning to detonation being promoted by the confinement given by the diaphragm. The detonating impulse then passes to and is augmented by the magazine, consisting of C.E. or picric acid pellets in contact with the detonator. Detonation of the magazine detonates the exploder fitted below the gaine, and this in turn detonates the high-explosive charge of the shell.

The different patterns of the No. 2 gaine differ slightly in details. In the later marks, the magazine is closed by a cap instead of a plug, so giving a smoother end to the gaine, and the powder pellets are in part contained in a copper or paper holder.

A proportion of the graze-type fuzes are arranged for delay action. The uses of the delay have already been indicated, see p. 51. The delay may be incorporated in the gaine. For this purpose a pellet of compressed mealed gunpowder

* Obsolete future manufacture.

GAINES, No. 2.

MARK I.

MARK III.

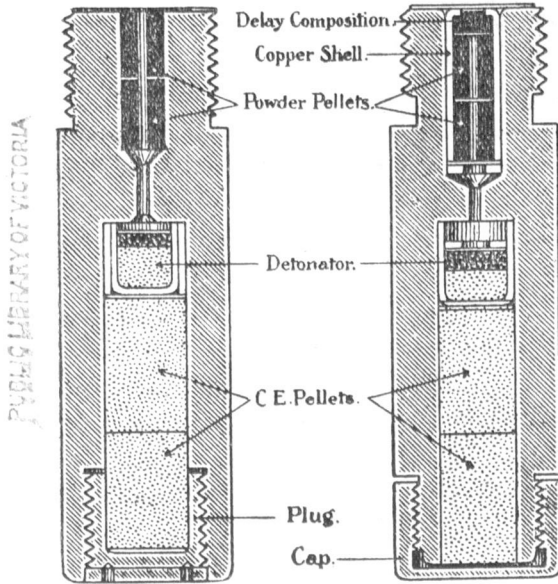

is fitted above the perforated powder pellets ; the pellet is pressed either directly in the gaine as in the Mark I, or in the holder for the perforated pellet as in the later marks. The delay pellet is ignited by the flash from the fuze and has to be burnt through before the perforated powder pellets are ignited, when the detonation of the gaine follows immediately. The delay is approximately 0.04 of a second.

Gaines provided with this delay are distinguished by a blue band painted round their bodies. Other markings found on earlier issues are a red band if the magazine is of C.E., or a yellow band if of picric acid ; but as gaines are not now filled with the latter explosive, these markings are now omitted

TIME, AND TIME AND PERCUSSION FUZES.

Shrapnel, star and incendiary shells, and also H.E. shells for air-ranging, &c., are fitted with time or time and percussion fuzes. Such a fuze provides for the bursting of the shell at any instant during its flight, at the expiration of an interval of time which is regulated by the setting of the fuze previous to loading. According to the setting, a longer or shorter length of composition, ignited at discharge, is allowed to burn before exploding a small magazine of gun-powder, which communicates a flash to the opening charge of the shell. A time and percussion fuze also includes a percussion mechanism of the graze type (p. 50), intended to ensure action on graze or impact, should the time portion fail or should it be set longer than the actual range either by accident or by design.

In the fuzes used with the present equipment the composition is pressed into two rings, and setting is effected by adjusting the position of one of these with respect to the fuze body; the second ring is fixed. The rings are secured together and to the body by the cap of the fuze.

Fuzes of this type are of two kinds, "tensioned" fuzes and "clamping" fuzes. With tensioned fuzes, the cap is screwed up during manufacture so as to exert sufficient pressure on the rings, and then securely fixed; and to effect a setting it is necessary only to manipulate the movable time ring, the tension being sufficient to enable this to be done with the key provided. But with clamping fuzes the cap is not fixed; and to set the fuze it is necessary to unscrew the cap, give the necessary movement to the ring, and then screw up the cap tightly so as to clamp the ring securely in position.

A clamping fuze cannot therefore be set so quickly; but on the other hand it provides greater security in the maintenance of the setting as is explained below. It is necessary, however, after clamping that the ring should be held so tightly that it cannot be turned with the fingers; and in all

cases the setting should be checked to see that no movement of the ring has taken place.

With the ring type of fuzes, the pressure applied to the rings prevents any accidental movement between the acts of setting and loading; it seals the gases produced by the combustion of the composition, limiting the burning to its end face, and at the same time giving the confinement necessary to ensure correct burning; it also prevents the entry of any propellant gases that might pass over the shell. If, therefore, the proper pressure is not applied to the rings, a premature or a blind may result.

It is found with fuzes of the tensioned type that there is in some cases, particularly after repeated re-setting, a loss of tension. The possible effects of such a loss have already been suggested. When correctly tensioned, it is impossible to turn the ring with the fingers; therefore if it can be turned easily it may be taken that there is a loss of tension, and the fuze should be rejected. No attempt should be made by a manipulation of the cap either to tighten a loose ring, or to release a ring found to be immovable; it is impossible with the keys provided to tighten the cap of a tensioned fuze satisfactorily.

The rate of burning of a time fuze depends on the pressure prevailing at the burning surface, and this again depends on the pressure at the outlets through which the gases produced by the burning of the composition exhaust into the atmosphere; according as this pressure is lower so the gases exhaust more freely and by decreasing the accumulation of heat at the burning surface, lower the rate of burning. During flight, the pressure at the outlets depends largely on the rate of revolution of the shell, its translatory velocity, the shape of the fuze, the position of the outlets with respect to the fuze-body, and to a minor extent on the height to which the shell is fired; in the result, the time of burning may be distinctly longer than the nominal time of burning at rest. Again, as the angular and translatory velocities of the shell depend on the piece from which it is fired and on the charges used, the settings required to give the same actual times of

burning when fired from different guns or howitzers or from the same howitzers but with different charges, may vary appreciably.

The time of burning at any pressure can be found by increasing or decreasing the time of burning of the fuze when at rest, and under normal pressure by one forty-fourth for each inch in barometric pressure below or above the normal. The correction applies strictly only for variations in pressure of the order of one inch and with the fuze at rest; for other conditions it is a rough approximation.

Time fuzes are made in lots of 2,000. The variations in the times of burning of the members of each lot are small, although there may be appreciable differences in the times of burning of different lots. Fuzes should therefore be grouped by lots for firing, and when a fresh lot is taken into use the corrector setting should be verified. As lots from the same manufacturer differ as a rule but little in their times of burning, these lots should be kept together as far as possible.

To enable this grouping to be carried out, the lot number of the fuze, together with the manufacturer's initials, are stencilled on the box in which the fuzed rounds are packed. This information is also given on the labels of the cylinders in which the fuzes, when issued separately, are packed; and it is stamped on the base of the fuze.

Every precaution is taken to prevent the access of moisture to the fuze composition. One effect of damp is to lengthen the time of burning; or it may even prevent ignition, and so lead to a blind. In other cases it may lead to prematures; thus the composition when damp swells, and the resulting expansion forces away the cap so that on drying the tension is lost and the flash can then pass over the rings and prematurely ignite the magazine.

For protection against damp, fuzes are waterproofed, and issued either packed in sealed tin cylinders or, if fitted to the shells, provided with sealed covers. Detailed descriptions of the cover and the method of waterproofing are given on p. 82.

FUZE, TIME AND PERCUSSION, No. 82 (40 seconds).

This fuze is used with the incendiary* shells of this equipment.

The body is of aluminium, and the time rings of brass. The lower portion of the body is screw-threaded to the 2-inch gauge up to the shoulder, which screws down on to the seating of the fuze-socket. A platform is formed above, on which rests the lower time ring. Above this is the upper time ring, secured against rotary movement, and retained by a cap which screws on to the upper part of the stem of the body. The cap is tightened so as to exert a pressure on the time rings, the pressure being such that the lower ring requires a standard "tension" to move it; the cap is then secured by its set-screw.

To set the fuze, the lower ring is turned with the key provided until the setting mark is opposite the desired reading on the scale engraved on the fuze body.

Each ring has a groove on its underside, forming a circle, broken by a bridge of solid metal. The composition is pressed into these grooves. When the fuze is set at safety—that is, with the setting mark opposite the red star on the body—the bridges of the upper and lower time rings mask the flash holes to the lower ring and magazine respectively. This provides a double safety; and fuzes should be kept set in this position during transport, either in their tins or when fitted to the shells.

Both time rings are provided with gas-escape holes closed by brass discs. In the upper time ring and the stem of the body is fitted the mechanism for igniting the composition when the shell is discharged from the gun. When the time safety-pin is withdrawn the safety-pellet is then only supported by its shearing wire. The wire is sheared at the shock of discharge, and the pellet sets back into a recess, allowing three centrifugal bolts to fly out by centrifugal

* Fuzes, T. and P., Nos. 83 and 83R, may be used in incendiary shells as an alternative to fuze, T. and P., No. 82.

FUZE, TIME AND PERCUSSION, No. 82.

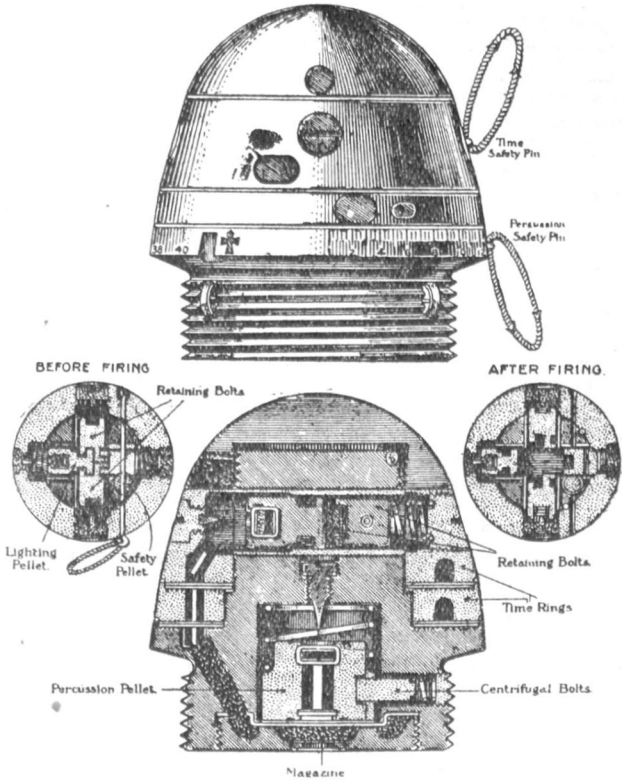

action and so release the detonator pellet, which also flies outwards, carrying the detonator on to a needle fitted in the upper time ring. The resulting flash fires a perforated powder pellet, which in turn ignites the composition in the upper ring. The composition burns round in the direction in which the shell is rotating until the flame reaches the opening in the upper face of the lower ring at the commencement of its composition. A powder pellet is fitted in this passage to ensure more certain ignition. The pellet is fired by the flash from the upper ring, igniting the composition in the lower ring, which burns round in the reverse direction until the flame reaches a powder pellet in the upper part of a diagonal channel leading to the magazine.

The percussion safety-pin, which locks the percussion pellet, is removed at the time of loading. On rotation of the shell the centrifugal bolts are spun out of their recesses in the pellet, but any tendency to creep forward during flight is prevented by a spiral spring. On graze or impact the pellet is carried forward, compressing the creep spring and firing the detonator, and the flash ignites the magazine.

For setting Key No. 36 is used. The peg on the key is inserted in the recess in the lower time ring. When fixing or removing the fuze, key No. 19 is used, the peg at the end of the curved portion being engaged in the slot in the fuze body; the inner face of the curved portion is bevelled so as to seat firmly on the sloping part of the body. The key is double-ended, and the ends are marked IN and OUT, to be used according as the fuze is to be screwed into or removed from the shell.

FUZE, TIME AND PERCUSSION NCS. 83 AND 83 R (30 seconds).

These fuzes are used in H.E. shells for air-ranging, &c. They may also be used in incendiary shells ; they are alternative to fuze, T. and P., No. 82.

In this fuze the construction and arrangement of the time rings is similar to that of No. 82 fuze described above, but the lighting and percussion mechanisms are different, and as the fuzes are of the clamping type* (p. 69), the procedure for setting is different. The cap is not permanently secured to the body, but is provided with a screwdriver slot to take key No. 48. When the fuze is to be set, the cap is loosened with this key ; the lower time ring is then turned to the desired setting either with the fingers or with key No. 18 ; the cap screwed up tightly so that the ring cannot be turned ; the setting checked. The time of burning of the fuze set full is approximately 30 seconds, but the scale is graduated in equal divisions from 0 to 22. Fuze lengths do not therefore approximately agree with the times of burning.

The lighting mechanism is fitted in a passage bored in the thickened portion of the upper time ring, or in a recess at the side or centre of the stem of the body. In the earlier patterns the lighting pellet fitted with a detonator is supported on a stirrup spring, and, in addition, a safety-pin to be removed immediately before loading, is fitted below the pellet to prevent any movement during transport ; but in later patterns the stirrup spring is replaced by a coil spring, and the needle is moved farther from the detonator, and the safety-pin is omitted. But in both cases the action is the same. At the shock of discharge the pellet sets back, either straightening out the arms of the stirrup or compressing the coil spring, and the needle fires the detonator ; the resulting flash then ignites a perforated powder pellet at the commencement of the composition of the upper time ring.

* Some earlier issues were of the tensioned type. These have not the screwdriver slot in the cap.

FUZE, TIME AND PERCUSSION, No. 83

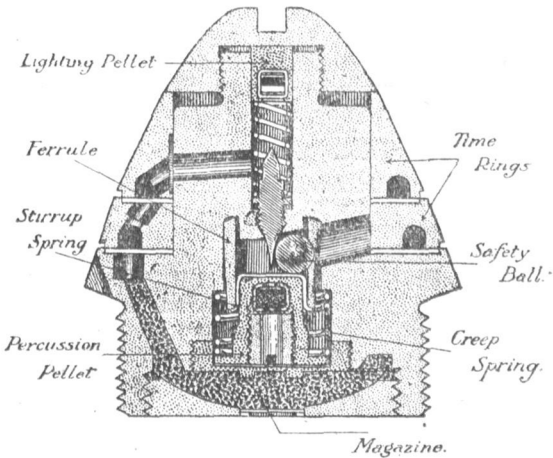
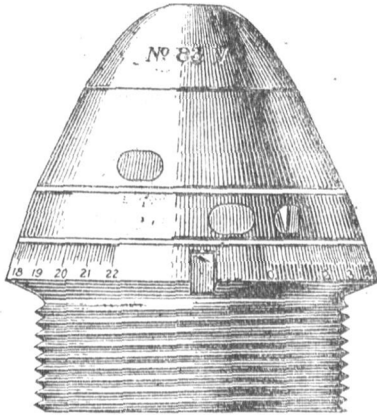

The No. 83 R fuzes correspond to the earlier marks of No. 83 fuzes, except that the stirrup springs are weaker, so that the lighting mechanism will arm with a lower acceleration of the shell. The later patterns of the No. 83 fuze, in which the lighting pellet is supported by a coil spring, are designed to arm at these lower values of acceleration. To distinguish the No. 83 R fuzes their caps are painted black.

The percussion pellet fitted with a detonator occupies a recess in the lower part of the body. A stirrup spring, fitting over the top of the pellet, supports a ferrule, which acts as a distance-piece between the pellet and the body, and prevents the needle from touching the detonator; in addition, a metal ball is interposed between the pellet and the top of the recess, and acts as an additional safeguard. At the shock of discharge the ferrule sets back over the pellet, straightening out the arms of the stirrup spring, but the pellet is prevented from rebounding by the ball which remains in position in front of the pellet. During flight the ball, owing to centrifugal action, moves outwards into a recess in the body, and the pellet is prevented from creeping forward by a coil spring, which has a bearing on a flange formed round the base of the pellet. On impact, the pellet flies forward, compressing the creep spring, and carries the detonator on to the needle. The resulting flash passes through a passage in the pellet and fires the magazine of the fuze.

For fixing or removing the fuze, keys Nos. 17 or 32 are used.

FUZE, T. & P., No. 88 (48 seconds).

This fuze is employed in H.E. shells for air-burst ranging. It is a variant of the No. 83 fuze which to give a longer time of burning has the lower ring filled with slow-burning composition. This ring is lacquered red.

Adapter, 2-inch fuze hole, No. 11.—This adapter is used in conjunction with fuze T. & P. No. 83 in high-explosive shells intended for air-ranging; it both supports the gaine and provides a safety-device for guarding the filling should the fuze act prematurely. The safety-device is a shutter. This is of the same type, a block moving in a slot, as that of the shutter of the No. 101E fuze, but it has a much greater sealing area; and it is this which determines its use, as the flash from the No. 83 fuze is much more powerful than that of the percussion fuzes Nos. 101E and 103, and could not be sealed by the shutters used with these fuzes.

The means for retaining the shutter in position are different. It is held in its closed position by a detent, the tail of which projects from the bed across which the shutter moves. On the shock of discharge the detent sets back, and the spin of the shell causes its tail to move outwards so that, when the spring re-asserts itself, the tail engages a shoulder at the upper part of the passage, and further movement is prevented. There is, therefore, no possibility that the detent will regain its original position and hold the shutter closed.

The shutter is arranged so that, in the closed position, its centre of gravity is slightly displaced towards the detent end of the slot, and the centrifugal action set up by the spin of the shell tends to cause the shutter to move further in this direction. But during the time the shell is accelerating the shutter is pressed tightly on to its bed, and the frictional resistance which results from this pressure overcomes the

ADAPTER, 2-INCH, FUZE HOLE, No. 11.

BEFORE FIRING.

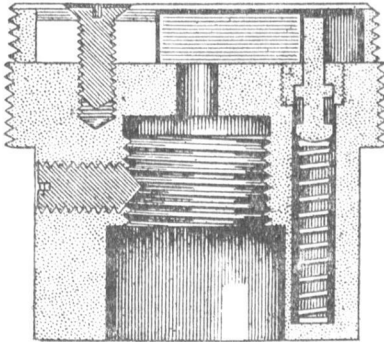

AFTER FIRING.

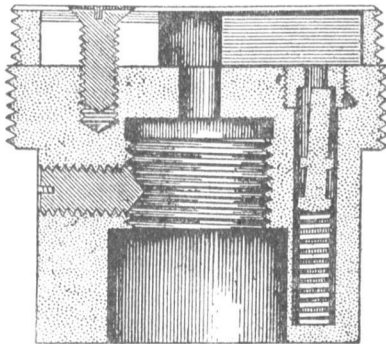

centrifugal effect, and the shutter remains stationary. It is only when this pressure is released—that is, when the shell leaves the bore—that centrifugal action takes effect; the shutter then moves outwards, unmasking the flash-hole to the gaine.

PRESERVATION OF FUZES.

As previously mentioned, fuzes deteriorate if the detonators or fillings become damp. The injury is permanent, and tends to increase with time, although there may be no further exposure. Damp acts on the detonators and also on the fuze composition; the effect on the latter has already been referred to (p. 71). If the detonators are affected, blinds or unsatisfactory bursts will be the result. Precautions have therefore to be taken to protect the fuzes. Particularly is this necessary with time fuzes. With the percussion fuzes used with these equipments, it may be taken that they have been adequately sealed to meet all ordinary conditions.

Fuzes, when issued separate from the shells, are packed in tin cylinders, the lids of which are sealed by a tin strip soldered on or by a tape band secured with shellac cement. The cylinder should not be opened sooner than is necessary, and then, if possible, in a dry atmosphere.

When in the shell, fuzes are protected by a careful sealing of the fuze-socket and of the grub-screw holes; in addition, the time fuzes are protected by sealed covers, and the joints of the fuze-body are waterproofed.

To waterproof a time fuze, waterproofing composition is rubbed into the joints of the time rings and into the gas-escape holes. If waterproofing composition is not available, *unthinned* Mark III luting may be used; but this tends to deteriorate and crumble when in contact with the rubber covers. When a fuze is set, the waterproof seal is broken; if the fuze is not to be used immediately the seal should be re-made and a cover fitted.

Covers are used only with time and T. & P. fuzes. With percussion fuzes covers are unnecessary since all joints are sealed during manufacture; but the caps of the No. 106 type fuzes should be kept screwed down tightly on to the dermatine washers. With the fuzed ammunition of the present equipment flexible indiarubber covers are used. These covers are moulded to the shape of the fuze, and are

of a length sufficient to project well on to the shell ; therefore they seal the fuze-socket. The method of fitting the cover is as follows :—All grease, waterproofing composition and luting are wiped from the fuze and the nose of the shell ; the cover and the fuze, if wet, are carefully dried ; a complete ring of Pettman's cement is painted round the nose of the shell immediately below the flange of the fuze, care being taken that the cement does not spread on to the scale so as to obliterate the markings ; the cover is then fitted with its protecting washer opposite the setting stud ; the cover is smoothed down by hand until it is pressed well on to the fuze, pressure on the studs being avoided since the cover is easily cut by their sharp edges ; the lower edge is then pressed on to the ring of Pettman's cement, and the joint made doubly secure by a coating of the same material.

Indiarubber covers harden and crack on storage ; they may also be torn or cut if the rounds are not handled with care. The covers must therefore be frequently inspected. If found to be deteriorated or damaged, they should be replaced immediately.

GLOSSARY.

Adjusted charge.—A charge of propellant adjusted in weight when at a temperature of 80° F., so as to give the normal velocity in a new gun.

Ballistite.—A propellant in the form of square flakes, and consisting of a mixture of guncotton and nitro-glycerine, gelatinised by acetone; the flakes may be graphited. For the 4.5-inch howitzer ballistite A is used—that is, ballistite of the modified A composition. Its size, 71, represents the thickness of the flakes in thousandths of an inch.

B.L. Ammunition.—Ammunition in which the shell and cartridge are separate, and the cartridge consists of a propellant charge in a fabric bag. The sealing devices for the breech-opening are carried entirely by the gun.

Composition Exploding, or C.E.—A high-explosive which is readily detonated; used in mines, and certain fuzes and exploders.

Cordite.—A propellant in the form of cords, sticks, or strands, and consisting of a mixture of guncotton, nitro-glycerine and mineral jelly, gelatinised by acetone; gives high temperatures in the chamber; commonly termed Cordite, Mark I. Its size is determined approximately by its diameter in hundredths of an inch.

Cordite M.D.—Cordite (Mark I) modified by a reduction in the proportion of nitro-glycerine so as to give lower temperatures in the chamber, and less erosion.

Cordite M.D.T.—A tubular form of Cordite M.D.

Cordite R.D.B.—A cordite propellant giving the same ballistics as Cordite M.D., but made up with a different form of guncotton. R.D.B. is an abbreviation for Research Department "B" formula.

Cordite R.D.B., Square Flake.—A flake form of Cordite R.D.B. For the 4.5-inch howitzer, size $2\frac{1}{2}/50$ is used. The size is represented by the thickness and the length of the side in hundredths of an inch.

Detonation.—The normal explosive action of high explosives; results from a detonating wave moving with extreme rapidity through the substance. The action being so extremely rapid, the resulting blow is correspondingly more violent and brusque. Compare *Explosion*.

Direct-Action or D.A. Fuzes.—A percussion fuze which functions only when a blow is actually delivered to the operative part; instantaneous in its action.

Exploder, Expldr., or Expr.—A small charge of high-explosive fitted into a cavity in high-explosive and other fillings, and the detonation of which effects the send-off of the main charge, or the burst of the shell.

Explosion.—The normal explosive action with propellants. The action consists of progressive burning; each layer is raised to its ignition temperature by heat directly transmitted from the layer preceding it. Compare *Detonation*.

Graze-Action Fuze.—A percussion fuze which functions when the forward velocity of the shell is checked. There is a slight delay in its action; in some cases the delay is intentionally increased.

G.S.—General service.

G.S. Gauge.—One of the gauges of the screw-threaded portion of fuze holes; one inch across, and slightly tapered.

High-explosive, or H.E.—An explosive with which the normal explosive action is detonation; used for filling shells, exploders, fuzes and detonators.

N.C.T. or Nitro-Cellulose Tubular.—A propellant consisting of gelatinised nitro-cellulose. Contains no nitro-glycerine. Made up as short cylinders, pierced longitudinally with one or more holes. The diameter of the cylinders expressed in hundredths of an inch gives the size of the propellant.

Quick-Firing, or Q.F. Ammunition.—Ammunition in which the propellant charge is contained in a brass case which is fitted with the means of ignition, and which in the gun acts as a sealing device for the breech-opening.

R.L.—The abbreviation or monogram marked on ammunition to denote that it has been manufactured or filled at the Royal Laboratory, Woolwich.

Time & Percussion, or T. & P. Fuzes.—Fuzes that can alternatively be made to function after a predetermined time or on impact.

T.N.T., Trotyl, or Tri-nitro-toluene.—A high explosive used in the fillings of shells and exploders.

2-inch Gauge.—The standard gauge in the land service for the screw-threaded portion of fuze holes—2 inches across, and parallel.